

University of Rajshahi

Rajshahi-6205

Bangladesh.

RUCL Institutional Repository

<http://rulrepository.ru.ac.bd>

Department of Applied Mathematics

PhD Thesis

2015

Solitary Wave Solutions of NLEEs in Plasma Physics and Engineering

Khan, Md. Ashrafuzzaman

University of Rajshahi

<http://rulrepository.ru.ac.bd/handle/123456789/282>

Copyright to the University of Rajshahi. All rights reserved. Downloaded from RUCL Institutional Repository.

**Ph.D.
Thesis**

Solitary Wave Solutions of NLEEs in Plasma Physics and Engineering

*Dissertation Submitted to the Department of Applied Mathematics
in Partial Fulfillment of the Requirements for the Degree of
Doctor of Philosophy in Applied Mathematics*

Md. Ashrafuzzaman Khan

By

Md. Ashrafuzzaman Khan

Session: 2012-2013

Roll No.: 12208

Registration No.: 1649



**Department of Applied Mathematics
Faculty of Science
University of Rajshahi
Rajshahi- 6205, Bangladesh**

**June
2015**

June 2015

Dedicated to

My parents, my wife, my beloved son, my niece and Tuhin's parents.

Solitary Wave Solutions of NLEEs in Plasma Physics and Engineering

*Dissertation Submitted to the Department of Applied Mathematics in
Partial Fulfillment of the Requirements for the Degree of Doctor of
Philosophy in Applied Mathematics*

By

Md. Ashrafuzzaman Khan

Session: 2012-2013

Roll No.: 12208

Registration No.: 1649

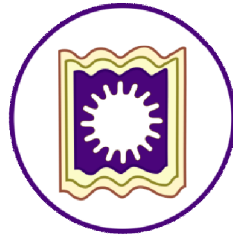

**Department of Applied Mathematics
Faculty of Science
University of Rajshahi
Rajshahi- 6205, Bangladesh**

June 2015

Declaration

I do hereby declare that the Ph.D. dissertation entitled “Solitary Wave Solutions of NLEEs in Plasma Physics and Engineering” is my original research work. Appropriate credit is given when ideas from other people’s works are used. The dissertation has not been formerly submitted anywhere for any degree.

Md. Ashrafuzzaman Khan

Ph.D. Research Fellow
&
Assistant Professor
Department of Applied Mathematics
University of Rajshahi
Rajshahi-6205
Bangladesh.

Certificate

I do hereby certify that the dissertation entitled “Solitary Wave Solutions of NLEEs in Plasma Physics and Engineering” submitted by Mr. Md. Ashrafuzzaman Khan in partial fulfillment of the requirements for the degree of **Doctor of Philosophy** in Applied Mathematics, under the Faculty of Science, University of Rajshahi, Rajshahi-6205, Bangladesh has been completed under my supervision. I believe that this dissertation is original one and it has not been submitted anywhere for any degree or diploma. I have gone through the final draft of the thesis and found it worth submission.

Therefore, I recommend and forward the thesis to the University of Rajshahi for necessary formalities towards the award of the degree of Doctor of Philosophy in Applied Mathematics.

Dr. Md. Ali Akbar

(Supervisor)
Associate Professor
Department of Mathematics
University of Rajshahi
Rajshahi-6205, Bangladesh

Acknowledgements

To begin with, my praises and thanks are due to almighty Allah who enabled me to finish my Doctor of Philosophy degree smoothly, and provided me with the competent supervisor like Dr. Md. Ali Akbar.

I am highly thankful to my supervisor, **Dr. Md. Ali Akbar**, Associate Professor, Department of Applied Mathematics, University of Rajshahi, Bangladesh for his insightful guidance, constructive support and never-failing patience. His all time encouraging conversations, friendly behavior, and unique way to make his students utilize their hidden research talents are extraordinary. He influences me to choose the field nonlinear evolution equations and solitary wave theory which ultimately appears tenable for me. I am extremely grateful for his continued help, enlightening discussions and proper direction throughout my research work. He rightly give me context and insight into the world of nonlinear evolution equations in mathematical physics, plasma physics and engineering.

I must extend my sincere thanks to Professor, Dr. Md. Abdul Haque, Chairman, Department of Applied Mathematics, University of Rajshahi, Rajshahi-6205, Bangladesh for providing me with the facilities during the course of thesis work. I am also deeply thankful to Professor Dr. M. Habibur Rahman, Dean, Faculty of Science, University of Rajshahi, Rajshahi-6205, Bangladesh for his cooperation through all kinds of rules and regulations within the provision of Rajshahi University. I also express gratefulness to my honorable teachers Professor Dr. Md. Zillur Rahman (retired), Professor Dr. Md. Hossain Ali, Ex-Chairman, Department of Applied Mathematics for their invaluable advice and numerous enlightening discussions. I also express my gratitude to all of my colleagues for

their advice, encouragement and help during my research work. Also, I wish to thank my teacher and M.Sc. supervisor Professor Dr. M. Ashabul Hoque and other teachers like Professor Dr. Md. Abdus Sattar (retired), Professor Dr. M. Wazed Ali Pramanik., Professor Mrs. Nazma Sultana, Professor Dr. Zulfiker Ali, Professor Dr. Nasima Akhter, Professor Dr. M. Asaduzzaman, Professor Dr. Shewli Shamim Shanta, Professor Dr. M. Lutfor Rahman, Professor Dr. Kalyan Kumar Dey, Professor Dr. Jogendra Nath Pramanik., Professor Dr. Gour Chandra Paul and Dr. Md. Sahadat Hossain, Department of Mathematics, University of Rajshahi, Rajshahi-6205, Bangladesh, for their supports and encouragements throughout my student life.

I would like to extend my thanks to Mr. Md. Mominul Islam, Assistant Professor, Department of English, University of Rajshahi, Rajshahi-6205, Bangladesh, for his help in editing the language of this dissertation.

I also express my thanks to my wife Mst. Mansura Akhtar for her tireless moral support, patience, sacrifice and kindness throughout my research. I also express my special thanks to my beloved son Md. Muhtasim-ul Haque Muhib because he don't disturb me when I worked for this dissertation. Through their love and devotion, this work has been possible.

Finally, thanks to my parents Md. Lutfar Rahman and Mst. Afroza Begum, my niece Mst. Afia Tanjim Rafida and my dear friend Tuhin's parents, without their support and encouragement throughout my life I would not have been in a position to embark on doctoral study.

June, 2015.

The Author

Contents

Declaration		i
Certificate		ii
Acknowledgements		iii-iv
Contents		v-vii
List of Figures		viii-xii
List of Publications		xiii
Abstract		xv
Chapter 1	Introduction	1-4
Chapter 2	The Literature Review and Proposal	5-20
2.1:	The Literature Review	5
2.2:	Wave and Soliton	15
2.3:	Motivation	18
2.4:	Objectives	19
2.5:	The Proposal	20
Chapter 3	Methodology	21-26
3.1:	The Modified Simple Equation (MSE) Method	22
3.2:	The (G'/G) -expansion Method	24
Chapter 4	Applications	27-96
4.1:	Applications of the MSE Method	28
4.1 (a):	The KdV Equation	29
4.1 (b):	The Boussinesq Equation	35
4.1 (c):	The Fifth-order KdV Equation	39
4.1 (d):	The Modified Schamel Equation for Acoustic Waves in Plasma Physics	47
4.1 (e):	The Modified Kadomtsev-Petviashvili (KP) Equation for Acoustic Waves in Plasma Physics	53
4.1 (f):	The Strain Wave Equation in Microstructured Solids	61
4.1(f)-I:	The Non-dissipative Case	61
4.1(f)-II:	The Dissipative Case	67

4.2:	Applications of the (G'/G)-expansion Method	74
4.2 (a):	The KdV Equation	75
4.2 (b):	The Boussinesq Equation	77
4.2 (c):	The Fifth-order KdV Equation	79
4.2 (d):	The Modified Schamel Equation for Acoustic Waves in Plasma Physics	81
4.2 (e):	The Modified Kadomtsev-Petviashvili (KP) Equation for Acoustic Waves in Plasma Physics	84
4.2 (f):	The Strain Wave Equation in Microstructured Solids	89
4.2(f)-I:	The Non-dissipative Case	89
4.2(f)-II:	The Dissipative Case	93
Chapter 5	The Graphical Representations and Physical Explanations	97-117
5.1:	The Graphical Representations	98
5.1 (a):	The KdV Equation	98
5.1 (b):	The Boussinesq Equation	100
5.1 (c):	The Fifth-order KdV Equation	101
5.1 (d):	The Modified Schamel Equation for Acoustic Waves in Plasma Physics	103
5.1 (e):	The Modified Kadomtsev-Petviashvili (KP) Equation for Acoustic Waves in Plasma Physics	105
5.1 (f):	The Strain Wave Equation in Microstructured Solids	106
5.1(f)-I:	The Non-dissipative Case	107
5.1(f)-II:	The Dissipative Case	108
5.2:	The Physical Explanations	111
5.2 (a):	The KdV Equation	111
5.2 (b):	The Boussinesq Equation	112
5.2 (c):	The Fifth-order KdV Equation	113
5.2 (d):	The Modified Schamel Equation for Acoustic Waves in Plasma Physics	114
5.2 (e):	The Modified Kadomtsev-Petviashvili (KP) Equation for Acoustic Waves in Plasma Physics	115
5.2 (f):	The Strain Wave Equation in Microstructured Solids	116
5.2(f)-I:	The Non-dissipative Case	116
5.2(f)-II:	The Dissipative Case	117

Chapter 6	Comparison, Results and Discussion	118-133
6.1:	Comparison between the Obtained Solutions by the MSE Method and the (G'/G) -expansion Method for the KdV Equation	119
6.2:	Comparison between the Obtained Solutions by the MSE Method and the (G'/G) -expansion Method for the Boussinesq Equation	121
6.3:	Comparison between the Obtained Solutions by the MSE Method and the (G'/G) -expansion Method for the Fifth-order KdV Equation	123
6.4:	Comparison between the Obtained Solutions by the MSE Method and the (G'/G) -expansion Method for the Modified Schamel Equation for Acoustic Waves in Plasma Physics	126
6.5:	Comparison between the Obtained Solutions by the MSE Method and the (G'/G) -expansion Method for the Modified Kadomtsev-Petviashvili (KP) Equation for Acoustic Waves in Plasma Physics	128
6.6:	Comparison between the Obtained Solutions by the MSE Method and the (G'/G) -expansion Method for the Strain Wave Equation in Microstructured Solids for Non-dissipative and Dissipative Cases	130
Chapter 7	Conclusion and Future Instructions	134-135
References		136-156

List of Figures

- Figure 1: Sketch of the anti-bell shape soliton $u_{1,1}$ in (4.1.17) to the KdV equation for $\delta = -2, \omega = -1$ within $-10 \leq x, t \leq 10$.
- Figure 2: Sketch of the singular multi-soliton $u_{1,2}$ in (4.1.18) to the KdV equation for $\delta = 1, \omega = 1$ within $-10 \leq x, t \leq 10$.
- Figure 3: Sketch of the periodic singular solution $u_{1,3}$ in (4.1.19) to the KdV equation for $\delta = 1, \omega = 0.5$ within $-10 \leq x, t \leq 10$.
- Figure 4: Sketch of singular periodic solution $u_{1,4}$ in (4.1.20) to the KdV equation for $\delta = -1, \omega = 1$ within $-10 \leq x, t \leq 10$.
- Figure 5: Sketch of the bell shape soliton $u_{1,5}$ in (4.1.23) to the KdV equation for $\delta = 1, \omega = -1$ within $-10 \leq x, t \leq 10$.
- Figure 6: Sketch of the singular bell shape soliton $u_{1,6}$ in (4.1.24) to the KdV equation for $\delta = -1, \omega = 1$ within $-10 \leq x, t \leq 10$.
- Figure 7: Sketch of the singular periodic solution $u_{1,7}$ in (4.1.25) to the KdV equation for $\delta = -1.5, \omega = -1$ within $-10 \leq x, t \leq 10$.
- Figure 8: Sketch of the singular periodic solution $u_{1,8}$ in (4.1.26) to the KdV equation for $\delta = -1.5, \omega = 0.5$ within $-10 \leq x, t \leq 10$.
- Figure 9: Shape of the anti-bell type soliton $u_{1,9}$ shown in (4.1.37) to the Boussinesq equation for $\omega = -0.75$ within $-10 \leq x, t \leq 10$.
- Figure 10: Shape of the singular bell type soliton $u_{1,10}$ shown in (4.1.38) to the Boussinesq equation for $\omega = -0.75$ within $-10 \leq x, t \leq 10$.
- Figure 11: Shape of the singular periodic solution $u_{1,11}$ shown in (4.1.39) to the Boussinesq equation for $\omega = -1.5$ within $-10 \leq x, t \leq 10$.
- Figure 12: Shape of the singular periodic solution $u_{1,12}$ shown in (4.1.40) to the Boussinesq equation for $\omega = -1.5$ within $-10 \leq x, t \leq 10$.
- Figure 13: Shape of anti-bell type soliton $u_{1,13}$ shown in (4.1.43) to the Boussinesq equation for $\omega = -1.5$ within $-10 \leq x, t \leq 10$.
- Figure 14: Shape of the singular bell type soliton $u_{1,14}$ shown in (4.1.44) to the Boussinesq equation for $\omega = -1.2$ within $-10 \leq x, t \leq 10$.
- Figure 15: Shape the singular periodic solution $u_{1,15}$ shown in (4.1.45) to the Boussinesq equation for $\omega = 0.001$ within $-10 \leq x, t \leq 10$.
- Figure 16: Shape the singular multiple solution $u_{1,16}$ shown in (4.1.46) to the Boussinesq equation for $\omega = 0.2$ within $-10 \leq x, t \leq 10$.

- Figure 17: Structure of bell shape soliton $u_{1,17}$ set down in (4.1.59) to the fifth-order KdV equation for $\alpha = -1$, $\beta = 1$, $\gamma = -1.5$ and $\mu = -1$ within $-10 \leq x$, $t \leq 10$.
- Figure 18: Structure of singular anti-bell shape soliton $u_{1,18}$ in (4.1.60) to the fifth-order KdV equation for $\alpha = -1$, $\beta = 1$, $\gamma = -1.5$ and $\mu = -1$ within $-10 \leq x$, $t \leq 10$.
- Figure 19: Structure of singular solution $u_{1,19}$ set down in (4.1.61) to the fifth-order KdV equation for $\alpha = 1$, $\beta = 1$, $\gamma = 1.5$ and $\mu = -1$ within $-10 \leq x$, $t \leq 10$.
- Figure 20: Structure of singular periodic solution $u_{1,20}$ set down in (4.1.62) to the fifth-order KdV equation for $\alpha = -1$, $\beta = 1$, $\gamma = -1$ and $\mu = -2$ within $-10 \leq x$, $t \leq 10$.
- Figure 21: Structure of anti-bell type soliton $u_{1,21}$ set down in (4.1.65) to the fifth-order KdV equation for $\alpha = 1$, $\beta = 1$, $\gamma = -1$ and $\mu = -1$ within $-10 \leq x$, $t \leq 10$.
- Figure 22: Structure of the single soliton $u_{1,22}$ set down in (4.1.66) to the fifth-order KdV equation for $\alpha = -1$, $\beta = 1$, $\gamma = 0.5$ and $\mu = -1$ within $-10 \leq x$, $t \leq 10$.
- Figure 23: Structure of singular periodic solution $u_{1,23}$ set down in (4.1.67) to the fifth-order KdV equation for $\alpha = -2$, $\beta = 2$, $\gamma = 2$ and $\mu = -2$ within $-10 \leq x$, $t \leq 10$.
- Figure 24: Structure of the singular periodic solution $u_{1,24}$ set down in (4.1.68) to the fifth-order KdV equation for $\alpha = 2$, $\beta = -2$, $\gamma = -2$ and $\mu = 2$ within $-10 \leq x$, $t \leq 10$.
- Figure 25: Form of the anti-bell shape soliton $u_{1,25}$ written down in (4.1.85) to the modified Schamel equation for $k = -2$, $\delta = -2$, and $\omega = -2$ within $0 \leq x$, $t \leq 1$.
- Figure 26: Form of singular bell shape soliton $u_{1,26}$ written down in (4.1.86) to the modified Schamel equation for $k = -2$, $\delta = -2$, and $\omega = -2$ within $-1 \leq x$, $t \leq 1$.
- Figure 27: Form of the figure of a part of the singular periodic solution $u_{1,27}$ written down in (4.1.87) to the modified Schamel equation for $k = -2$, $\delta = -2$, $\omega = -1$ within $-3 \leq x$, $t \leq 3$.
- Figure 28: Form of the figure of a part of the singular periodic solution $u_{1,28}$ written down in (4.1.88) to the modified Schamel equation for $k = -2$, $\delta = -2$, $\omega = -0.5$ within $-5 \leq x$, $t \leq 5$.
- Figure 29: Form of singular bell shape soliton $u_{1,29}$ written down in (4.1.92) to the modified Schamel equation for $k = -1$, $\delta = -1$, and $\omega = -1$ within $-3 \leq x$, $t \leq 3$.
- Figure 30: Form of the solution $u_{1,30}$ written down in (4.1.93) to the modified Schamel equation for $k = 1$, $\delta = -0.5$, $\omega = 2$ within $-5 \leq x$, $t \leq 5$.

- Figure 31: Form of the figure as the part of the singular periodic solution $u_{1,31}$ written down in (4.1.94) to the modified Schamel equation for $k = -2$, $\delta = -2$, $\omega = 0.3$ with $-5 \leq x, t \leq 5$.
- Figure 32: Form of the figure as the part of the singular periodic solution $u_{1,32}$ written down in (4.1.95) to the modified Schamel equation for $k = 2$, $\delta = 2$, and $\omega = 0.3$ within $-5 \leq x, t \leq 5$.
- Figure 33: Diagram of the bell shape soliton $u_{1,33}$ mentioned in (4.1.112) to the modified KP equation for $k = -2$, $\alpha = -2$, $\beta = 2$, $\delta = -2$ and $\omega = -2$ within $-3 \leq x, t \leq 3$.
- Figure 34: Diagram of the singular multi-soliton $u_{1,34}$ mentioned in (4.1.113) to the modified KP equation for $k = -1.5$, $\alpha = -1$, $\beta = 1$, $\delta = -1$ and $\omega = -1$ within $0 \leq t \leq 3$, $-3 \leq x \leq 3$
- Figure 35: Diagram of the singular periodic solution $u_{1,35}$ mentioned in (4.1.114) to the modified KP equation for $k = 2$, $\alpha = 1$, $\beta = 1$, $\delta = 1$, $\omega = -1$ within $-8 \leq x, t \leq 8$.
- Figure 36: Diagram of the singular periodic solution $u_{1,35}$ mentioned in (4.1.115) to the modified KP equation for $k = 2$, $\alpha = 1$, $\beta = 1$, $\delta = 1$ and $\omega = -1$ within $-8 \leq x, t \leq 8$.
- Figure 37: Diagram of the solution $u_{1,37}$ mentioned in (4.1.119) to the modified KP equation for $k = -2$, $\alpha = -2$, $\beta = -2$, $\delta = -2$ and $\omega = -2$ within $-8 \leq x, t \leq 8$.
- Figure 38: Diagram of the singular bell shape soliton $u_{1,38}$ mentioned in (4.1.120) to the modified KP equation for $k = -2$, $\alpha = -2$, $\beta = -2$, $\delta = -2$ and $\omega = -2$ within $-8 \leq x, t \leq 8$.
- Figure 39: Diagram of the periodic solution $u_{1,39}$ mentioned in (4.1.121) to the modified KP equation for $k = -2$, $\alpha = -2$, $\beta = 0.45$, $\delta = -1$ and $\omega = -1$ within $-8 \leq x, t \leq 8$.
- Figure 40: Diagram of the periodic solution $u_{1,40}$ mentioned in (4.1.122) to the modified KP equation for $k = -2$, $\alpha = -2$, $\beta = 0.45$, $\delta = -1$ and $\omega = -1$ within $-8 \leq x, t \leq 8$.
- Figure 41: Plot of bell shape soliton $u_{1,41}$ set down in (4.1.135) to the strain wave equation in microstructured solids for non-dissipative case when $\varepsilon = 0.1$, $\alpha_1 = 1$, $\alpha_3 = 1$, $\alpha_4 = 1.25$ and $\omega = -1.5$ within $-8 \leq x, t \leq 8$.
- Figure 42: Plot of multi-soliton $u_{1,42}$ set down in (4.1.136) to the strain wave equation in microstructured solids for non-dissipative case when $\varepsilon = 0.1$, $\alpha_1 = -2$, $\alpha_3 = 2$, $\alpha_4 = 2$ and $\omega = 1.1$ within $-8 \leq x, t \leq 8$.
- Figure 43: Plot of singular periodic solution $u_{1,43}$ set down in (4.1.137) to the strain wave equation in microstructured solids for non-dissipative case when $\varepsilon = 0.1$, $\alpha_1 = 2$, $\alpha_3 = -2$, $\alpha_4 = -2$ and $\omega = 2$ within $-2 \leq x, t \leq 2$.

- Figure 44: Plot of singular periodic solution $u_{1,44}$ written down in (4.1.138) to the strain wave equation in microstructured solids for non-dissipative case when $\varepsilon = 0.1, \alpha_1 = 2, \alpha_3 = -2, \alpha_4 = -2$ and $\omega = 2$ within $-2 \leq x, t \leq 2$.
- Figure 45: Plot of anti-bell shape soliton $u_{1,45}$ written down in (4.1.141) to the strain wave equation in microstructured solids for non-dissipative case when $\varepsilon = 0.1, \alpha_1 = 2, \alpha_3 = -2, \alpha_4 = -2$ and $\omega = -2$ within $-8 \leq x, t \leq 8$.
- Figure 46: Plot of singular anti-bell shape soliton $u_{1,46}$ written down in (4.1.142) to the strain wave equation in microstructured solids for non-dissipative case when $\varepsilon = 0.1, \alpha_1 = -2, \alpha_3 = -2, \alpha_4 = -2$ and $\omega = -2$ within $-8 \leq x, t \leq 8$.
- Figure 47: Plot of periodic multi-solution $u_{1,47}$ mentioned in (4.1.143) to the strain wave equation in microstructured solids for non-dissipative case when $\varepsilon = 0.1, \alpha_1 = -2, \alpha_3 = -1, \alpha_4 = 1$ and $\omega = 1.25$ within $-8 \leq x, t \leq 8$.
- Figure 48: Plot of periodic multi-solution $u_{1,48}$ mentioned in (4.1.144) to the strain wave equation in microstructured solids for non-dissipative case when $\varepsilon = 0.1, \alpha_1 = -2, \alpha_3 = -1, \alpha_4 = 1$ and $\omega = 1.25$ within $-8 \leq x, t \leq 8$.
- Figure 49: Sketch of the kink soliton $u_{1,49}$ shown in (4.1.156) to the strain wave equation for dissipative case when $\varepsilon = 0.1, \alpha_1 = -2, \alpha_2 = -2, \alpha_3 = -2$ and $\alpha_4 = -2$ within $-8 \leq x, t \leq 8$ for $\omega = \theta_1$.
- Figure 50: Sketch of the kink soliton $u_{1,49}$ shown in (4.1.156) to the strain wave equation for dissipative case when $\varepsilon = 0.1, \alpha_1 = -2, \alpha_2 = -2, \alpha_3 = -2$ and $\alpha_4 = -2$ within $-8 \leq x, t \leq 8$ for $\omega = -\theta_1$.
- Figure 51: Sketch of the kink soliton $u_{1,49}$ shown in (4.1.156) to the strain wave equation for dissipative case when $\varepsilon = 0.1, \alpha_1 = -2, \alpha_2 = -2, \alpha_3 = -2$ and $\alpha_4 = -2$ within $0 \leq t \leq 10, -5 \leq x \leq 5$ for $\omega = \theta_2$.
- Figure 52: Shape of the kink soliton $u_{1,49}$ shown in (4.1.156) to the strain wave equation for dissipative case when $\varepsilon = 0.1, \alpha_1 = -2, \alpha_2 = -2, \alpha_3 = -2$ and $\alpha_4 = -2$ within $0 \leq t \leq 10, -5 \leq x \leq 5$ for $\omega = -\theta_2$.
- Figure 53: Sketch of the singular solution $u_{1,50}$ shown in (4.1.157) to the strain wave equation for dissipative case when $\varepsilon = 0.1, \alpha_1 = -2, \alpha_2 = -2, \alpha_3 = -2$ and $\alpha_4 = -2$ within $-25 \leq t \leq 25, -20 \leq x \leq 20$ for $\omega = \theta_1$.
- Figure 54: Sketch of the singular solution $u_{1,50}$ shown in (4.1.157) to the strain wave equation for dissipative case when $\varepsilon = 0.1, \alpha_1 = -2, \alpha_2 = -2, \alpha_3 = -2, \alpha_4 = -2$ within the range $-25 \leq t \leq 25, -20 \leq x \leq 20$ for $\omega = -\theta_1$.
- Figure 55: Sketch of the singular solution $u_{1,50}$ shown in (4.1.157) to the strain wave equation for dissipative case when $\varepsilon = 0.1, \alpha_1 = -2, \alpha_2 = -2, \alpha_3 = -2$ and $\alpha_4 = -2$ within $-25 \leq t \leq 25, -20 \leq x \leq 20$ for $\omega = \theta_2$.
- Figure 56: Sketch of the singular solution $u_{1,50}$ shown in (4.1.157) to the strain wave equation for dissipative case when $\varepsilon = 0.1, \alpha_1 = -2, \alpha_2 = -2, \alpha_3 = -2$ and $\alpha_4 = -2$ within $-25 \leq t \leq 25, -20 \leq x \leq 20$ for $\omega = -\theta_2$.

- Figure 57: Sketch of the kink solution $u_{1,51}$ shown in (4.1.160) to the strain wave equation for dissipative case when $\varepsilon = 0.1$, $\alpha_1 = 1$, $\alpha_2 = 1$, $\alpha_3 = 0.5$ and $\alpha_4 = 1$ within $-10 \leq x$, $t \leq 10$ for $\omega = \vartheta_1$.
- Figure 58: Sketch of the steeped kink solution $u_{1,51}$ shown in (4.1.160) to the strain wave equation for dissipative case when $\varepsilon = 0.1$, $\alpha_1 = 1$, $\alpha_2 = 1$, $\alpha_3 = 0.5$ and $\alpha_4 = 1$ within $-10 \leq x$, $t \leq 10$ for $\omega = -\vartheta_1$.
- Figure 59: Sketch of the kink solution $u_{1,51}$ in (4.1.160) to the strain wave equation for dissipative case when $\varepsilon = 0.1$, $\alpha_1 = 1$, $\alpha_2 = 1$, $\alpha_3 = 0.5$ and $\alpha_4 = 1$ within $-10 \leq x$, $t \leq 10$ for $\omega = \vartheta_2$.
- Figure 60: Sketch of the kink solution $u_{1,51}$ in (4.1.160) to the strain wave equation for dissipative case when $\varepsilon = 0.1$, $\alpha_1 = 1$, $\alpha_2 = 1$, $\alpha_3 = 0.5$ and $\alpha_4 = 1$ within $-10 \leq x$, $t \leq 10$ for $\omega = -\vartheta_2$.
- Figure 61: Sketch of the single soliton solution $u_{1,52}$ in (4.1.161) to the strain wave equation for dissipative case when $\varepsilon = 0.1$, $\alpha_1 = 1$, $\alpha_2 = 1$, $\alpha_3 = 0.5$ and $\alpha_4 = 1$ within $-10 \leq x$, $t \leq 10$ for $\omega = \vartheta_1$.
- Figure 62: Sketch of the solution $u_{1,52}$ in (4.1.161) to the strain wave equation for dissipative case when $\varepsilon = 0.1$, $\alpha_1 = 1$, $\alpha_2 = 1$, $\alpha_3 = 0.5$ and $\alpha_4 = 1$ within $-10 \leq x$, $t \leq 10$ for $\omega = -\vartheta_1$.
- Figure 63: Sketch of the singular kink type solution $u_{1,52}$ in (4.1.161) to the strain wave equation for dissipative case when $\varepsilon = 0.1$, $\alpha_1 = 1$, $\alpha_2 = 1$, $\alpha_3 = 0.5$ and $\alpha_4 = 1$ within $-10 \leq x$, $t \leq 10$ for $\omega = \vartheta_2$.
- Figure 64: Sketch of the solution $u_{1,52}$ in (4.1.161) to the strain wave equation for dissipative case when $\varepsilon = 0.1$, $\alpha_1 = 1$, $\alpha_2 = 1$, $\alpha_3 = 0.5$ and $\alpha_4 = 1$ within $-10 \leq x$, $t \leq 10$ for $\omega = -\vartheta_2$.

List of Publications

1. **M. Ashrafuzzaman Khan** and M. Ali Akbar, Exact and Solitary Wave Solutions to the Fifth-order KdV Equation by Using the Modified Simple Equation Method, **Applied and Computational Mathematics**, 4(3) (2015) 122-129. DOI: 10.11648/j.acm.20150403.14.
2. **M. Ashrafuzzaman Khan** and M. Ali Akbar, Solitary Wave Solutions to the Strain Wave Equation in Microstructured Solids through the Modified Simple Equation Method, **Physical Science International Journal**, (2015) (accepted for publication), **(proof has been attached in the next page)**.
3. **M. Ashrafuzzaman Khan** and M. Ali Akbar, Solitary Wave Solutions to the Strain Wave equation in Microstructured Solids and Fifth-order KdV equation through the (G'/G) -expansion method, **Applied and Computational Mathematics**, (submitted, 2015).

Abstract

Although the modified simple equation (MSE) method effectively provides exact solitary wave solutions to nonlinear evolution equations (NLEEs) in the field of applied mathematics, mathematical physics, plasma physics and engineering, it has some limitations. When the balance number is greater than one, usually the method does not give any solution. In this dissertation, we have exposed a process as to how to implement the MSE method to solve the NLEEs for balance number two. In order to verify the process, some NLEEs have been solved by means of this scheme, and we found some fresh traveling wave solutions. When the parameters receive special values, solitary wave solutions are derived from the exact traveling wave solutions and we have analyzed the solitary wave properties by the graphs of the solutions. These solitary wave solutions include soliton, kink shape soliton, singular kink shape soliton, bell shape soliton, singular bell shape soliton, anti-bell shape soliton, singular anti-bell shape soliton, etc. The attraction of the MSE method is that it is consistent, peaceful, authentic, and we found some fresh new traveling wave solutions other than the existing methods, such as, the basic (G'/G) -expansion method. We emphasize the implementation of the MSE method, how to examine the solutions to NLEEs for balance number two and also compare the solutions obtained by the MSE method and the well-known existing (G'/G) -expansion method. This shows the validity, usefulness, and necessity of the MSE method and our graphical representations describe the obtained traveling wave solutions.

Chapter 1

Introduction

The mathematical modeling of physical phenomena that change over time depends closely on the system of differential equations, namely, ordinary and partial differential equations. Through the diverse fields, like the natural and physical sciences, economics, epidemiology, neural networks, bioscience, mechanics etc., the mathematical models are developed to study these phenomena. In spite of the fact that these models provided the nature of the fields, the adequacy of their contribution to the common characteristics that make it possible to examine the different groups of them within a unified theoretical structure or mathematical form of the differential equations, which are linear, nonlinear, homogeneous or non-homogeneous equations. Solution procedures to linear differential equations are relatively easy and well recognized. But for the nonlinear equations it is not so easy to solve them and in some cases it is not possible and in general, approximations are typically used. Many scientists observed the fascinating element in the nature of nonlinear and for the fundamental understanding of nature, the science of nonlinear is the most important border. This study is an area of functional analysis, usually called the theory of evolution equations. These equations are basically nonlinear evolution equations (NLEEs). Therefore, in the natural sciences, it is very significant to study the solutions of NLEEs to uncover the obscurity of many events and processes.

The mathematical form of a NLEE is $u_t = f(u)$, *i. e.* a nonlinear partial differential equation with respect to time derivative. The linear heat equations or wave equations recounting heat conduction or vibration of cord are two simple examples of evolution equations. However, there are many nonlinear evolution equations which usually arising

from physics, plasma physics, mechanics, engineering, biology, chemistry, electrical circuits, solid state physics, high-energy physics, condensed matter physics, meteorology, oceanic phenomena, quantum mechanics, optical fibers, elastic media, fluid mechanics, acoustics, protein chemistry, mathematical biology, water surface gravity waves, ion acoustic waves in plasma, material science etc., should be investigated. Actually almost all the evolution equations concerning physical phenomena are nonlinear. The properties of each nonlinear equation are distinct and every nonlinear equation has its own peculiarity. Therefore, complication of NLEEs has drawn a lot of attention of many mathematicians and scientist who are involved with nonlinear science. For better understanding of the inner structure of the phenomena, as well as their further applications in practical life, exact solutions might play a fundamental role. The exact solutions can explain the problems precisely and the physical significance of the system duly. In addition to the physical significance, the close-form solutions to NLEEs assist the numerical solvers to evaluate the precision of their results and help them in the stability analysis. Exact solutions contain some arbitrary constants, when the constants receive some particular values solitary wave solutions are originated from the exact traveling wave solutions. A solitary wave is a localized gravity wave that occurs from the balance between dispersive effects and nonlinearity. When a solitary wave remains in its shape and velocity during its collision with another wave of the same kind, though possibly for a phase shift, is call a soliton. *i. e.* it can be treated like a particle that upholds its profile when it travels at constant speed. Equations with soliton solutions have a profound mathematical structure. Solitary waves arise equally in continuous and discrete systems and in both one and multiple spatial dimensions. Key issues in studying solitary waves also include linear versus nonlinear, persistent versus transient, integrable versus non-

integrable, asymptotics, localization in physical space versus Fourier space, and the effects of noise.

Therefore, it is significant to seek as many solitary wave solutions as possible to the NLEEs. In the recent years, significant efforts have been made by various groups of scientists to find solitary wave solutions to the NLEEs. All nonlinear equations cannot be solved by a particular method. Therefore, they established several methods to obtain exact solitary wave solutions, such as, the inverse scattering method, the Backlund transformation method, the Adomian decomposition method, the variational iteration method, the He's homotopy perturbation method, the Jacobi elliptic function method, the homogeneous balance method, the tanh-function method, the sine-cosine method, the F-expansion method, the Exp-function method, the ansatz method, the (G'/G) -expansion method, the modified simple equation (MSE) method, the $\exp(-\varphi(\eta))$ -expansion method, etc.

The MSE method is an effective method in searching exact solitary wave solutions to NLEEs, but the method has some shortcomings. When the balance number is greater than one, typically there arise difficulties in solving the NLEEs by means of the MSE method. One cannot use the MSE method in straight away. In this dissertation, we have by using the MSE method established a procedure to examine the exact solitary wave solutions to NLEEs whose balance number is two. Inserting the assumed solution to the corresponding ordinary differential equation and then equating the coefficients of $(\psi(\xi))^{-j}$, $j = 0, 1, 2, 3, \dots$ yield an over-determined set of algebraic and differential equations. During determination of the unknown function, there is born a third order linear ordinary differential equation in $\psi(\xi)$ and ξ . If in the solution of $\psi(\xi)$, ξ appears as a polynomial, it will not be eligible to be received as solitary wave solution, because for

solitary wave solution, $|u| \rightarrow 0$ as $\xi \rightarrow \infty$. Therefore, the coefficients of the polynomial must be zero. This constraint is essential to solve NLEEs for higher balance number. This procedure plays a very important role and can be applied to many NLEEs. The solutions obtained by this technique might play very important role in the field of applied mathematics, mathematical physics, plasma physics and engineering. We have analyzed and illustrated the solitary wave properties of the solutions by graph.

Chapter 2

The Literature Review and Proposal

Preview Material

- 2.1: The Literature Review
- 2.2: Wave and Soliton
- 2.3: Motivation
- 2.4: Objectives
- 2.5: The Proposal

2.1: The Literature Review

In general physical systems are explained by nonlinear partial differential equations. The mathematical modeling of intricate phenomena in applied mathematics, physics, mathematical physics, bioscience, medical science, plasma physics, microstructured solid materials in engineering fields that change over time are closely related to the study of variety of systems of ordinary and partial differential equations. Similar models have also evolved in various fields of study, ranging from the natural and physical sciences, population ecology to economics, infectious disease epidemiology, neural networks, biology, mechanics etc. Therefore, mathematical theories are very much important to find solutions to nonlinear partial differential equations because physical systems are generally explained by nonlinear equations. In spite of the eclectic nature of the fields wherein these models are formulated, different groups of scientists contribute adequate common attributes that make it possible to examine them within a unified theoretical structure. Such study is an area of functional analysis usually called the theory of evolution

equations. Therefore, the investigation of solutions to NLEEs plays a very important role to uncover the obscurity of many phenomena and processes throughout the natural sciences. But, one of the essential problems is to obtain their exact solutions. Because, nonlinear processes are one of the major confrontations and difficult to manage since the nonlinear characteristic of the system abruptly changes owing to slight changes of valid parameters along with time. Thus, the issue becomes further complex and hence needs ultimate solution. In this case, advance nonlinear techniques are important to solve the problems which are inherently nonlinear, especially those involving differential equations, dynamical systems and associated areas (Alam, 2014).

Therefore, in order to find out exact solutions to NLEEs, different groups of mathematicians, physicist, and engineers have been working tirelessly. With the development of symbolic computation software, like, Mathematica, Maple or Matlab, direct method for searching solutions to NLEEs have become an attractive area of research. This software assists us by computing the complicated and cumbersome algebraic and linear differential equations speedily and successfully. As a result, they have been able to contribute significantly. Accordingly, in the recent years, they have established several methods to search exact solutions to NLEEs, for instance, the Exp-function method (He and Wu, 2006; He et al., 2012; Akbar and Ali, 2012; Manafian and Zamanpour, 2013; Mohyud-Din et al., 2009a; Misirli and Gurefe, 2011; Naher et al., 2011a; Naher et al., 2012; Yildirim and Pinar, 2010; Zhang, 2010), the Darboux transformation method (Leble and Ustinov, 1993; Matveev and Salle, 1991; Rogers and Schief, 2002), the inverse scattering method (Ablowitz and Clarkson, 1991; Baldock et al., 1981; Ghosh and Nandy, 1999), the Hirota's bilinear method (Hirota, 1973; Hirota, 2004; Hirota and Satsuma, 1981), the Backlund transformation method (Jianming et al., 2011; Miura, 1978; Rogers and Shadwick, 1982), the symmetry method (Bluman and

Kumei, 1989; Olver, 1986), the homogeneous balance method (Wang, 1995; Zayed et al., 2004a), the tanh method (Abdou, 2007; El-Wakil and Abdou, 2007; Fan, 2000; Malfliet and Hereman, 1996; Nassar et al. 2011; Salas and Gomez, 2008; Sekulic et al., 2011; Yusufoglu and Bekir, 2008; Zayed et al., 2004b), the Painleve expansion method (Weiss et al., 1982), the Jacobi elliptic function method (Chen and Wang, 2005; Porubov, 1996; Xu, 2006), the unified algebraic method (Fan, 2002), the hyperbolic function method (Inc and Evans, 2004; Zayed et al., 2004b), the Adomian decomposition method (Helal and Mehana, 2006; Kaya, 2001; Kaya, 2004; McOwen, 2004), the generalized Riccati equation method (Yan and Zhang, 2001), the ansatz method (Hu , 2001; Hu and Zhang, 2001), the sine-cosine method (Wazwaz, 2004; Yusufoglu and Bekir, 2006; Yan and Zhang, 1999), the Miura transformation method (Bock and Kruskal, 1979), the first integral method (Taghizadeh and Mirzazadeh, 2011), the He's homotopy perturbation method (Ganji, 2006; Ganji and Rafei, 2006; Ganji et al., 2007), the Cole-Hopf transformation method (Salas and Gomez, 2010), the Lie group symmetry method (Guo and Lin, 2010), the auxiliary equation method (Sirendaoreji, 2007), the F-expansion method (Wang and Li, 2005; Wang and Zhou, 2003), the modified extended direct algebraic method (Soliman and Abdo, 2009), the parameter-expansion method (He and Shou, 2007), the variational iteration method (Mohyud-Din, 2008; Mohyud-Din et al., 2009b-c; Noor and Mohyud-Din, 2008; Noor et al., 2008), the $\exp(-\varphi(\eta))$ -expansion method (Khan and Akbar, 2013a; Hafez et al., 2015; Rahman et al., 2014a-b; Roshid et al., 2014; Uddin et al., 2014), the Sumudu transform method (Belgacem, 2006; Belgacem, 2007; Belgacem, 2009; Belgacem, 2010; Belgacem and Karaballi, 2006; Belgacem et al., 2003; Chaurasia et al., 2012; Watugala, 1993), the multiple Exp-function algorithm (Ma and Zhu, 2012), the homotopy analysis method (Domairry et al., 2009; Joneidi et al., 2010), the generalized tanh-coth method (Gomez and Salas, 2008; Jawad, 2012), the

spectral-homotopy analysis method (Makukula et al., 2010; Motsa et al., 2010a-b; Sibanda et al., 2010) and so on.

Li et al. (Li et al., 2004) implemented the generalized Riccati equation expansion method, in which $G(\xi)$ satisfied an auxiliary equation: $G'(\xi) = C_1 G^2(\xi) + C_2 G(\xi) + C_3$ where C_1, C_2 and C_3 are arbitrary constants, which is generalized Riccati equation. They applied this method and obtained some solutions to the (3+1)-dimensional Jimbo-Miwa equation. Zhu (Zhu, 2008) revealed the generalized Riccati equation mapping with the extended tanh-function method and solved the (2+1)-dimensional Boiti-Leon-Pempinelle equation. Salas (Salas, 2008) expressed the projective Riccati equation method and solved the Caudrey-Dodd-Gibbon equation. Bekir and Cevikel (Bekir and Cevikel, 2011) attached the tanh-coth method combined with the Riccati equation. They found the traveling solutions to the (2 + 1)-dimensional breaking soliton equations by this method. Guo et al. (Guo et al., 2011) used the extended Riccati equation mapping method. They applied this method to obtain the traveling wave solutions for the diffusion reaction equation and the mKdV equation with variable coefficient. Zayed et al. (Zayed et al., 2014) applied the improved Riccati equation mapping method to constructed many exact solutions of a NLEE in nanobiosciences and biophysics which describe a model of microtubules as nonlinear RLC transmission line.

Wang et al. (Wang et al., 2008a) found a method, called the (G'/G) -expansion method which is straightforward and the algorithm for searching the unknown parameters is simple. In this method, it is assume that the solution of the NLEEs can be presented by a polynomial of (G'/G) , i.e. $\sum_{i=0}^n a_i (G'/G)^i$, wherein $G = G(\xi)$ satisfies a second-order linear ordinary differential equation (ODE) $G'' + \lambda G' + \mu G = 0$, in which λ and μ are arbitrary constants. They applied this method and find some fresh solutions to the

Korteweg-de Vries equation, the mKdV equation, the variant Boussinesq equation and the Hirota-Satsuma equation. Wang et al. also (Wang et al., 2008b) used this method to obtain the traveling wave solutions involving parameters to the Broer-Kaup equation and the approximate long water wave equation. Later, several researchers have applied this method and solved different types of NLEEs. For example: Bekir (Bekir, 2008) applied the method and constructed traveling wave solutions to the Boussinesq equation, the modified Zakharov-Kuznetsov equation and the Konopeichenko-Dubrovsky equation. Zayed (Zayed, 2009a) found the solitary wave solutions involving parameters for some NLEEs in mathematical physics via the (2+1)-dimensional Painleve integrable Burgers equation, the (2+1)-dimensional Nizhnik-Novikov-Vesselov equation, the (2+1)-dimensional Boiti-Leon-Pempinelli equation and the (2+1)-dimensional dispersive long wave equations. Zayed and Gepreel (Zayed and Gepreel, 2009) also solved the combined Korteweg-de Vries equation, the modified Korteweg-de Vries equation, the reaction-diffusion equation, the compound KdV-Burgers equation, and the generalized shallow water wave equation and they have found some traveling wave solutions of these equations. Zhang (Zhang, 2009) explored new application of this method to some special NLEEs, namely the Eckhaus equation, the modified Burgers equation and a kind of nonlinear reaction-diffusion equation, the balance numbers of which are not positive integers and obtained exact traveling wave solutions. Abazari (Abazari, 2010) investigated general exact solutions of three NLEEs namely, the Tzitzeica equation, the Dodd-Bullough-Mikhailov equation and the Tzitzeica-Dodd-Bullough equation. Taghizade and Neirameh (Taghizade and Neirameh, 2010) investigated the traveling wave solutions of the TRLW equation and the Gardner equation. Zayed (Zayed, 2010) found the solitary solutions of NLEEs in the mathematical physics via the (3+1)-dimensional potential- YTSF equation, the (3+1)-dimensional generalized shallow water

equation, the (3+1)- dimensional Kadomtsev-Petviashvili equation, the (3+1)-dimensional modified KdV Zakharov-Kuznetsev equation and the (3+1)-dimensional Jimbo-Miwa equation. Feng et al. (Feng et al., 2011) examined traveling wave solutions to the Kolmogorov-Petrovskii-Piskunov equation. Kheiri et al. (Kheiri et al., 2011) found some traveling wave solutions to the Burgers, Burgers-Huxley and modified Burgers-KdV equations. Naher et al. (Naher et al., 2011b) obtained some solitary solutions to the Caudrey-Dodd-Gibbon equation. Roozi and Mahmeiani (Roozi and Mahmeiani, 2011) searched some solitary wave solutions to the (2+1)-dimensional Kadomtsev-Petviashvili equation. Akbar et al. (Akbar et al., 2012a) obtained exact traveling wave solutions to the generalized Bretherton equation. Recently, Taha et al. (Taha et al., 2013) applied this method to NLEEs in plasma physics and found some fresh solitary wave solutions to the Schamel modified equation for ion-acoustic waves, one dimensional form of the Schamel-KdV equation and modified Kadomtsev-Petviashvili equation. Khan and Akbar (Khan and Akbar, 2015c) applied this method to obtain some solitary wave solutions to the fifth-order KdV equation in mathematical physics and the strain wave equation in microstructured solids in the engineering field.

Later on many researchers developed, modified and improved the (G'/G) -expansion method and also established this method in subsequent:

Zayed (Zayed, 2009b) offered a new approach of the (G'/G) -expansion method in which $G(\xi)$ satisfies the auxiliary equation: $\{G'(\xi)\}^2 = C_1 G^4(\xi) + C_2 G^2(\xi) + C_3$, called Jacobi elliptical equation, when C_1 , C_2 and C_3 are arbitrary constants. He applied this method to obtain exact solutions of the NLEEs in mathematical physics via the (3+1)-dimensional potential-YTSF equation, the (3+1)-dimensional modified KdV-Zakharov-Kuznetsev equation, the (3+1)-dimensional Kadomtsev-Petviashvili equation and the (1+1)-dimensional KdV equation.

Guo and Zhou (Guo and Zhou, 2010) provided the extended (G'/G) -expansion method. They used this method and made some fresh solutions to the Whitham-Broer-Like equations and the coupled Hirota-Satsuma KdV equations. In this method, the solution of the NLEEs were presented in the form $a_0 + \sum_{i=1}^n \left\{ a_i \left(\frac{G'}{G} \right)^i + b_i \left(\frac{G'}{G} \right)^{i-1} \sqrt{\sigma \left\{ 1 + \frac{1}{\mu} \left(\frac{G'}{G} \right) \right\}} \right\}$, where a_0 , a_i and b_i ($i = 1, 2, 3, \dots, n$) are constants to be determined later, $\sigma = \pm 1$ and $G(\xi)$ satisfies the linear ODE $G'' + \mu G = 0$, when μ is a arbitrary constant. Then many researchers applied this extended method and found the traveling wave solutions to some NLEEs, such as: Zayed and Al-Joudi (Zayed and Al-Joudi, 2010) solved the (1+1)-dimensional modified Benjamin-Bona-Mahony (BBM) equation, the (2+1)-dimensional typical breaking soliton equation, the (1+1)-dimensional classical Boussinesq equations and the (2+1)-dimensional Broer-Kaup-Kuperschmidt equations in mathematical physics. Zayed and El-Malky (Zayed and El-Malky, 2011) constructed the traveling solutions to some (3+1)-dimensional NLEEs in mathematical physics, namely the nonlinear (3+1)-dimensional potential-YTSF equation and the (3+1)-dimensional generalized shallow water equation. Zhang et al. (Zhang et al., 2010) recruited the improved (G'/G) -expansion method, in which the solutions of NLEEs were presented in the form $\sum_{i=-n}^n a_i \left(\frac{G'}{G} \right)^i$ and they obtained the traveling wave solutions to the Zakharov-Kuznetsov-BBM equation and the (2+1)-dimensional dispersive long wave equations. Then some researchers used this method and illustrated the traveling wave solutions to NLEEs, such as: Zayed and Gepreel (Zayed and Gepreel, 2010) found the traveling wave solutions to the Konopelchenko-Dubrovsky equation, the Karsten-Krasil Shchik equation, the Whitham-Broer-Kaup equation and the fifth-order KdV equations. Naher and Abdullah (Naher and Abdullah, 2012a) obtained some traveling wave solutions of the combined KdV-mKdV equation. Naher and Abdullah (Naher and Abdullah, 2012b) also

organized the new traveling wave solutions to the (2+1)-dimensional modified Zakharov-Kuznetsov equation.

Afterwards, Xiao et al. (Xiao et al., 2010) introduced the $(G'/G, 1/G)$ -expansion method and they generated the traveling wave solutions to the Zakharov equations. Later, some researchers: Zayed and Abdelaziz (Zayed and Abdelaziz, 2012) used this method and found some solutions to the nonlinear KdV-mKdV equation. Zayed et al. (Zayed et al., 2012) applied this method and found the traveling wave solutions to the nonlinear (3+1)-dimensional Kadomtsev-Petviashvili equation.

Zayed (Zayed, 2011a) also offered the (G'/G) -expansion method combined with the Riccati equation in which $G(\xi)$ satisfies the Riccati equation: $G'(\xi) = C_1 G^2(\xi) + C_2$, where C_1 and C_2 are arbitrary constants.

Akbar et al. (Akbar et al., 2012b) proposed a generalized and improved (G'/G) -expansion method in which the solutions presented in the form $\sum_{i=-n}^n \frac{e_{-n}}{(d+(G'/G))^i}$, where any one of e_{-n} or e_n may be zero, but both e_{-n} or e_n cannot be zero at the same time, when the solution's term $G(\xi)$ satisfies an auxiliary equation to the second order linear ODE $G'' + \lambda G' + \mu G = 0$, in which λ and μ are arbitrary constants. They applied this method and constructed some traveling wave solutions to the KdV equation, the ZKBBM equation and the strain wave equation in microstructured solids. Akbar et al. (Akbar et al., 2013) also organized the exact traveling wave solutions to the (2+1)-dimensional Boussinesq and Kadomtsev-Petviashvili equation. Naher et al. (Naher et al., 2013) used this method and evaluated some solutions to the (3+1)-dimensional modified KdV-Zakharov-Kuznetsev equation.

In the past years, Naher and Abdullah (Naher and Abdullah, 2013) implemented a new approach of (G'/G) -expansion method and solved the KdV equation. They used the

solution of the form: $\sum_{j=0}^N \alpha_j H^j + \sum_{j=1}^N \beta_j H^{-j}$ where either α_N or β_N may be zero, but both α_N and β_N cannot be zero at a time and α_j, β_j are arbitrary constants to be determined later and $H(\xi) = \frac{G'}{G}$, in which the term $G(\xi)$ satisfies the auxiliary equation of the second order nonlinear ODE: $AGG'' - BGG' - C(G')^2 - EG^2 = 0$. Afterwards, several researchers, like Alam and Akbar (Alam and Akbar, 2013a-c; Alam and Akbar, 2014a-c), Hasan et al. (Hasan et al., 2013) and Alam et al. (Alam et al., 2013a-b; Alam et al., 2014a-c) investigated traveling wave solutions to some NLEEs, such as, the KP-BBM equation, the simplified MCH equation, the (1+1)-dimensional combined KdV-mKdV equations, the Benjamin-Ono equation, the Zakharov-Kuznetsov-Benjamin-Bona-Mahony (ZK-BBM) equation, the (3+1)-dimensional potential-YTSF equation, the (2+1)-dimensional modified Zakharov-Kuznetsov equation, the mKdV equation, the Gardner equation, the fifth-order KdV equation, the (2+1)-dimensional breaking soliton equation, the (3+1)-dimensional Zakharov-Kuznetsov equation, the Burgers equation, the (3+1)-dimensional mKdV-ZK equation, the (1+1)-dimensional compound KdVB equation, the strain wave equation in microstructured solids and the Boussinesq equation.

Also Naher and Abdullah (Naher and Abdullah, 2014) implemented the further extension of the generalized and improved (G'/G) -expansion method and used the solutions of the form: $\sum_{j=-N}^N \alpha_j (d + H)^j + \sum_{j=1}^N \beta_j (d + H)^{-j}$ where any one of α_{-N} or α_N or β_N may be zero, but these α_{-N} and α_N and β_N cannot be zero at the same time and α_j, β_j and d are arbitrary constants to be determined later and $H(\xi) = \frac{G'}{G}$, in which the term $G(\xi)$ satisfies the same auxiliary equation (Naher and Abdullah, 2013). They used this method and obtained some exact solutions to the ZKBBM equation.

Later, Alam et al. (Alam et al., 2014d) offered the novel (G'/G) -expansion method. They applied this method and obtained many new exact solutions to the Boussinesq equation. Afterwards, many researchers investigated many NLEEs to construct traveling wave solutions, such as, Shakeel et al. (Shakeel et al., 2014), Shakeel and Mohyud-Din (Shakeel and Mohyud-Din, 2014), Hafez et al. (Hafez et al., 2014), Alam et al. (Alam et al., 2014e), Alam and Akbar (Alam and Akbar, 2014d-e) applied this method and constructed exact solutions to the time fractional simplified modified Camassa-Holm equation, the ZK-BBM equation, the Klein-Gordon equation, the (1+1)-dimensional KdV equation, the Benjamin-Ono equation, the Burgers equation and the nonlinear (1+1)-dimensional modified BBM equation.

In the recent past years, Jawad et al. (Jawad et al., 2010) proposed a method named the MSE method. In this method, the solution represented in the form $u(\xi) = \sum_{j=0}^N a_j \left\{ \frac{\psi'(\xi)}{\psi(\xi)} \right\}^j$, where a_j ($j = 0, 1, 2, \dots, N$) are arbitrary constants and the function $\psi(\xi)$ is an unknown function to be determined. They applied this method and solved the NLEEs, namely, the Fitzhugh-Nagumo equation and the Sharma-Tasso-Olver equation. By applying this method many researchers solved some NLEEs, for example: Zayed (Zayed, 2011b) applied this method and analyzed the exact solutions of the Sharma-Tasso-Olver equation. Salam (Salam, 2012) evaluated the traveling wave solution to the modified Liouville equation by means of this method. Zayed and Ibrahim (Zayed and Ibrahim, 2012) established the MSE method and found the traveling solutions to the (1+1)-dimensional modified KdV equation and the (1+1)-dimensional reaction-diffusion equation. Also Zayed and Ibrahim (Zayed and Ibrahim, 2013) searched the traveling wave solutions to the (1+1) dimensional generalized shallow water-wave equation and the (2+1)-dimensional KdV-Burgers equation. Zayed and Arnous (Zayed

and Arnous, 2013a-b) apply the MSE method and found some new exact solutions with parameters to the (2+1)-dimensional Konopelchneko-Dubrovsky equations, the (2+1) dimensional Nizhnik-Novikov-Vesselov equations, the (1+1)-dimensional nonlinear Burgers-Huxley equation, the (2+1)-dimensional cubic nonlinear Klein-Gordon equation and the (2+1)-dimensional nonlinear Kadomtsev-Petviashvili-Benjamin-Bona-Mahony (KP-BBM) equation. Khan et al. (Khan et al., 2013) investigated the traveling wave solutions to the nonlinear Drinfel'd-Sokolov-Wilson equation and modified Benjamin-Bona-Mahony equations. Khan and Akbar (Khan and Akbar, 2013b and 2014) used this method and constructed the traveling wave solutions to NLEES, i.e. the coupled Konno-Oono equations, the variant Boussinesq equations, the (2 +1)-dimensional Zoomeron equation and the Burgers equations. Inspire of the MSE methods of numerical results are very effective. Very recently, Khan and Akbar (Khan and Akbar, 2015a) established a technique for the MSE method and found some fresh solutions to the fifth-order KdV equation in mathematical physics. Khan and Akbar (Khan and Akbar, 2015b) also applied this method and obtained some exact solutions to the strain wave equation in microstructured solids in the field of engineering. We have discussed about this technique of the MSE method in Section 3.1.

2.2: Wave and Soliton

Wave refers to the physical movement of medium up and down or back and forth. Along wave, energy transfers from one place to another place. When wave travels in a medium then energy is transferred from one place of the medium to another without causing any permanent displacement of the medium. A wave is called a traveling wave in which the medium moves in the direction of prorogation of the wave (Wazwaz, 2009). When a wave travels it lose energy gradually, called the dissipative wave. A dissipative wave

loses amplitude due to loss of energy over time, as its velocity varies with the wave number. Typically, dispersion of water waves plainly referred to the waves include different wavelengths at different phase speeds, which means that, the happening of the wave speed varies with a wave number. Mathematically the third order spatial derivatives express the dispersion which loses the energy and the nonlinear term steeped the wave. Therefore, the delicate balance between the dispersion and nonlinearity conserve the velocity and shape of the traveling wave. This causes the solitary wave. If the solution depends only on the difference between the two coordinates of the partial differential equations, then the solution holds the shape of exact solutions called solitary waves. Within localized gravity remain solitary waves maintaining their coherence and finite amplitude and propagate with constant speed and shape. Solitons are found in many physical phenomena (Khan, 2014).

It is John Scott Russell who in August 1834 first observed a large projection of water slowly travel without change in shape on the Edinburgh-Glasgow canal (Scotland). He marked that the hump of water was traveling still retaining its shape for a long interval of time along the channel of water. He called it a great wave of translation which refers to the solitary wave or soliton (Wazwaz, 2009).

In Russell's own words: "I was observing the motion of a boat which was rapidly drawn along a narrow channel by a pair of horses, when the boat suddenly stopped not so the mass of water in the channel which it had put in motion; it accumulated round the prow of the vessel in a state of violent agitation, then suddenly leaving it behind, rolled forward with great velocity, assuming the form of a large solitary elevation, a rounded, smooth and well-defined heap of water, which continued its course along the channel apparently without change of form or diminution of speed. I followed it on horseback, and overtook

it still rolling on at a rate of some eight or nine miles an hour, preserving its original figure some thirty feet long and a foot to a foot and a half in height. Its height gradually diminished, and after a chase of one or two miles I lost it in the windings of the channel. Such in the month of August 1834, was my first chance interview with that singular and beautiful phenomenon which I have called Wave of translation.”

Now solitary waves or solitons refer to this single humped wave of bulge of water. The solitons are localized, highly stable waves that retain its identity (shape and speed), upon interaction—was discovered experimentally by Russell. Empirically he obtained the relation, $c^2 = g(h + a)$ where, the speed of solitary wave is c , h is the finite depth of water, g is the acceleration of gravity and a is the maximum amplitude upon the water surface (Wazwaz, 2009). Further research concerning the discovery of solitary waves attracted a lot of scientists. Dutch scientists, Diederik Johannes Korteweg and his student Gustav de Vries conduct enormous research to study the concept NLEE. The equation now carries the names of Korteweg and de Vries (KdV) and has already appeared in a work on water waves (Zabusky and Kruskal, 1965; Wazwaz, 2009). It is especially significant as the prototype example of an exactly solvable model and it also describes the propagation of plasma waves in a dispersive medium. This equation shows that dispersion and nonlinearity in its simplest form is

$$u_t + \alpha u u_x + u_{xxx} = 0,$$

where the terms u_t means the time evaluation of wave propagation, uu_x means the nonlinearity explanations for steepen of wave and u_{xxx} means the linear dispersion. It describes the spreading of wave (Khan, 2014).

Many researchers, scientists, mathematicians, physicists with authenticated brainwork, have already performed in a work on water waves. In 1872, Boussinesq worked on water

waves with generic model for the study of weakly nonlinear long waves, incorporating leading order nonlinearity and dispersion terms as the KdV equation.

The narrow-minded small effects due to nonlinearity system tend to localize the wave as a layer of an optical fiber or shallow water. Due to dispersion the spreading of a wave packet should be balanced exactly. The balance between the nonlinear steepens and dispersion explains the single humped waves which relate to the formulation of solitons. The effects of nonlinearity and dispersion between the stability of solitons derive from the weak equilibrium.

In 1965, numerically investigating Zabusky and Kruskal discovered that solitary waves undergo nonlinear interaction in the KdV equation. Further, the waves emerge from the nonlinear interaction containing the waves amplitude, original shape and speed and preserve energy and mass. Thus the only effect of the interaction was a phase shift. The special determining feature is that the solitary waves retain their identities and their character bears particle like behavior, called the solitary waves solitons (Zabusky and Kruskal, 1965). They signify particle like quantities emphasizing the birth of soliton. The interaction of two solitons marked the authenticity of the preservation of shapes and speeds of the steady pulse like solitons. Thus the collision of KdV solitons is considered elastic. Afterwards the soliton names have been conceived by Zabusky and Kruskal to photon, phonon, proton, etc. in spite of the fact that name solitary wave is more general. Actually, solitons are treated as special types of solitary waves (Wazwaz, 2009).

2.3: Motivation

NLEEs are derived from many fields of mathematics. At present NLEEs are not only controlled by mathematical fields, which are also revealed outside of mathematics, such as, physics, mechanics, meteorology, fluid mechanics, biology, material science,

economics, plasma physics, engineering fields, bioscience, etc. Such as, the KdV equation, $u_t + u u_x + \delta u_{xxx} = 0$ for the shallow water waves and internal waves; the Boussinesq equation, $u_{tt} - u_{xx} - (u^2)_{xx} + u_{xxxx} = 0$ is very important in the fields of surface wave propagation in coastal regions, heat and mass transfer, biology, ecology, crystallization, plasma physics, and reaction-diffusion systems; the fifth-order KdV equation: $u_t + \alpha u u_x + \beta u^2 u_x + \gamma u_{xxx} + \mu u_{xxxxx} = 0$, which is a very important equation in the field of surface wave propagation on shallow water surfaces; the modified Schamel equation: $u_t + u^{1/2} u_x + \delta u_{xxx} = 0$ is significant in the field of acoustic waves in plasma physics; the modified Kadomtsev-Petviashvili equation in the form: $(u_t + \alpha u^{1/2} u_x + \beta u_{xxx})_x + \delta u_{yy} = 0$ is important for ion-acoustic waves in plasma physics; the strain wave equation in microstructured solids: $u_{tt} - u_{xx} - \varepsilon \alpha_1 (u^2)_{xx} - \gamma \alpha_2 u_{xxt} + \delta \alpha_3 u_{xxxx} - (\delta \alpha_4 - \gamma^2 \alpha_7) u_{xxtt} + \gamma \delta (\alpha_5 u_{xxxxt} + \alpha_6 u_{xxtt}) = 0$ is important in the field of engineering, there arise two cases: non-dissipative case, $u_{tt} - u_{xx} - \varepsilon \alpha_1 (u^2)_{xx} + \delta \alpha_3 u_{xxxx} - \delta \alpha_4 u_{xxtt} = 0$ and dissipative case, $u_{tt} - u_{xx} - \varepsilon \{ \alpha_1 (u^2)_{xx} + \alpha_2 u_{xxt} - \alpha_3 u_{xxxx} + \alpha_4 u_{xxtt} \} = 0$ (Bekir, 2008; Ei-Kalaawy, 2011; Khan and Akbar, 2015c; Pastrone, 2009; Pastrone et al., 2004; Porubov and Pastrone, 2004; Samsonov, 2001; Taha et al., 2013; Wang et al., 2008a).

2.4: Objectives

This dissertation has been developed through the MSE method: how to implement this method and to investigate for distinguishing exact solitary wave solutions to NLEEs by applying some new technique, when the balance number is greater than one. Changing the value of arbitrary constants stress from the exact traveling wave solutions is to form some new solitary wave solutions or solitons. And the ultimate aspiration is to explore the possibility of the comparisons of my studied MSE method with another existing method, the (G'/G) -expansion method.

2.5: The Proposal

Jawad et al. (Jawad et al., 2010) proposed a method named, the MSE method and many researchers have been applied this method but this method has some abridgement when the balance number of the NLEEs is greater than one. Although a few equations have been solved by some researchers (Salam, 2012; Zayed, 2013; Zayed and Arnous, 2013a-b; Zayed and Ibrahim, 2013), but there is no guideline, how one can solve other NLEEs for higher balance number. In this dissertation, we will consider some NLEEs; the balance number for each of these equations is two. If the balance number is greater than one, usually there arise difficulties in solving the NLEEs by means of the MSE method.

In this dissertation, we will investigate the MSE method to explore new exact traveling wave solutions to NLEEs for balance number two. We need to take in some strategy to obtain the solutions of NLEEs. We consider NLEEs of the form:

$$H(u, u_t, u_x, u_y, u_z, u_{tt}, u_{xx}, u_{yy}, u_{zz}, \dots) = 0,$$

where $u = u(x, y, z, t)$ is an unknown function, H is a polynomial in $u(x, y, z, t)$ and its partial derivatives, which include the highest order derivatives and nonlinear terms of the highest order, and the subscripts represent the partial derivatives.

In **Chapter 3**, we will discuss the methodologies. In **Chapter 4**, the MSE method and the (G'/G) -expansion method have been applied in different NLEEs. In **Chapter 5**, the graphical representations and the physical explanations are provided. In **Chapter 6**, the obtained solutions by the MSE method have been compared with the solutions obtained by the (G'/G) -expansion method. Finally, in **Chapter 7**, we draw our conclusion and provided future directions.

Chapter 3

Methodology

Preview Material

- 3.1: The Modified Simple Equation (MSE) Method
- 3.2: The (G'/G) -expansion Method

In this chapter, we have discussed two methods, namely, the MSE method (Jawad et al., 2010) together with the developing process and the (G'/G) -expansion method established by Wang et al. (Wang et al., 2008a). The MSE method is easy, straightforward, and a powerful mathematical tool for solving different types of NLEEs for balance number one. In the recent past years, the method has been receiving much attention of the physicist, mathematicians, engineers and scientist for finding the new exact solutions to NLEEs. The ability of MSE method to be functional for most of the NLEEs, when balance number is one in mathematics, applied mathematics, mathematical physics, nuclear physics, fluid mechanics, plasma physics, liquid crystals, solid state physics, biophysics, mathematical biology, bio-genetics, geochemistry, high-energy physics, condensed matter physics, chemical physics, propagation of shallow water waves, atmospheric, the wave propagation phenomena, oceanic phenomena, meteorology, neural physics, quantum mechanics, nonlinear optics, most population models in ecology, optical fibers, elastic media, acoustics, electromagnetic radiation reactions, chemical kinematics, electricity, electrical circuits, population dynamics, magneto fluid dynamics, chemistry, population models, biology, protein chemistry, chemically reactive materials, ion acoustic waves in plasma, theory of Bose-Einstein condensates, water surface gravity waves, the heat flow

and the wave propagation phenomena in physics etc. But the MSE method has some limitations, when the balance number of the corresponding ordinary differential equation (ODE) is greater than one, usually the method does not give any solution. The MSE method and the developed process have been discussed in the following section.

3.1: The Modified Simple Equation (MSE) Method

First of all, we have described the MSE method which is used by many researchers to examine solitary wave solutions to NLEEs for balance number one. Only a few researchers have employed this method and solve a small number of NLEEs. But, they did not provide any direction to solve other NLEEs for future researchers.

Therefore, we have recounted the MSE method for finding the exact solitary wave solutions, when balance number is two. Let us consider the NLEE in the following form:

$$P(u, u_t, u_x, u_y, u_z, u_{tt}, u_{xx}, u_{yy}, u_{zz}, \dots) = 0, \quad (3.1.1)$$

where $u = u(x, y, z, t)$ represents an unidentified function, P represents a polynomial of $u(x, y, z, t)$ and its derivatives in which the highest order derivatives and nonlinear terms of the highest order are associated and the subscripts denote the partial derivatives. In order to solve the NLEE (3.1.1) by means of the MSE method (Jawad et al., 2010; Khan and Akbar, 2013b and 2014; Khan et al., 2013; Zayed, 2011b; Zayed and Arnous, 2013a-b; Zayed and Ibrahim, 2012), we have to execute the following steps:

Step 1: We combine the real variables x, y, z and t by the travelling wave variable ξ , in the following form:

$$\xi = x + y + z \pm \omega t, \quad u(x, y, z, t) = U(\xi), \quad (3.1.2)$$

where ω be the velocity of the traveling wave. The traveling wave transformation (3.1.2) permits us in reducing Eq. (3.1.1) into an ODE for $u = U(\xi)$:

$$F(U, U', U'', U''', U^{(iv)}, U^{(v)}, \dots) = 0, \quad (3.1.3)$$

where F represents a polynomial of U and its derivatives and the superscripts indicate the ordinary derivatives with respect to ξ , wherein $U'(\xi) = \frac{dU}{d\xi}$.

Step 2: We assume that Eq. (3.1.3) has the traveling wave solution in the following form:

$$u(\xi) = \sum_{j=0}^N a_j \left\{ \frac{\psi'(\xi)}{\psi(\xi)} \right\}^j, \quad (3.1.4)$$

where a_j ($j = 0, 1, 2, \dots, N$) are unknown constants to be determined, such that $a_N \neq 0$, and the function $\psi(\xi)$ is an unknown function to be evaluated later, $\psi'(\xi) \neq 0$. In tanh-function method, sine-cosine method, Jacobi elliptic function method, (G'/G) -expansion method, Exp-function method etc., the solutions are initiated in terms of some auxiliary functions established in advance, but in the MSE method, $\psi(\xi)$ is neither a pre-defined function nor a solution of any pre-defined differential equation. Therefore, it is not possible to conjecture from ahead what kind of solutions one might obtain through this method. This is the individuality and distinction of this method. Therefore, some fresh solutions might be found by this method (Khan and Akbar, 2013c).

Step 3: The positive integer N appearing in Eq. (3.1.4) can be determined by taking into account the homogeneous balance between the highest order nonlinear terms and the derivatives of highest order occurring in Eq. (3.1.3). If the degree of $U(\xi)$ is, $\deg[U(\xi)] = N$, therefore, the degree of the other expressions will be as follows:

$$\deg \left[\frac{U^m(\xi)}{d\xi^m} \right] = N + m, \quad \deg \left[U^m \left\{ \frac{U^l(\xi)}{d\xi^l} \right\}^p \right] = mN + p(N + l).$$

Step 4: We substitute (3.1.4) into (3.1.3) and then we account the function $\psi(\xi)$. As a result of this substitution, we get a polynomial of $\left(\frac{1}{\psi(\xi)} \right)$ and its derivatives. In the

resultant polynomial, we equate all the coefficients of $\left(\frac{1}{\psi(\xi)}\right)^i$, ($i = 0, 1, 2, 3, \dots$) to zero, which yields a set of algebraic and differential equations for a_i ($i = 0, 1, 2, \dots, N$), $\psi(\xi)$ and other needful parameters.

Step 5: The solutions of the set of algebraic and differential equations obtained in Step 4, provide the values of a_i ($i = 0, 1, 2, \dots, N$), $\psi(\xi)$ and other needful parameters.

But, it is not smooth to get the values of the parameters a_i and the unknown function $\psi(\xi)$ by solving the system of over-determined algebraic and differential equations. Therefore, there is a gap of research to invent the best and simple way to determine the values of the parameters and the function. Only a small number of researchers (Salam, 2012; Zayed, 2013; Zayed and Arnous, 2013a-b; Zayed and Ibrahim, 2013) have solved a few equations by the MSE method for balance number two by iterative searching procedure. They did not establish any specific technique for the feature researchers.

In this dissertation, we have established an avenue to get the parameters a_i ($i = 0, 1, 2, \dots, N$) and the unknown function $\psi(\xi)$: during the derivation period of $\psi(\xi)$, we have to avoid third and higher order differential equation, if it is not possible, then for getting $\psi(\xi)$ from the third or higher order differential equation, we must avoid the polynomial type solution of $\psi(\xi)$. To this end, we need to integrate the differential equation two or more times. This time, the integral constant should be zero except for the first and last integration (Khan and Akbar, 2015a-b).

3.2. The (G'/G) -expansion Method

The (G'/G) -expansion method was developed by Wang et al. (Wang et al., 2008a) to examine the traveling wave solutions to NLEEs emerge in applied mathematics, mathematical physics, plasma physics and engineering. In this section, this method has

been discussed to investigate the exact traveling wave solutions. They considered the NLEE in the following form:

$$Q(u, u_t, u_x, u_y, u_z, u_{tt}, u_{xx}, u_{yy}, u_{zz}, \dots) = 0, \quad (3.2.1)$$

where $u = u(x, y, z, t)$ denotes an unknown function, Q denotes a polynomial of $u(x, y, z, t)$ and its derivatives in which the highest order derivatives and nonlinear terms are related and the subscripts stand for the partial derivatives.

Step 1: They combined the real variables x, y, z and t by the compound variable ξ , in the following way:

$$\xi = x + y + z \pm \omega t, \quad u(x, y, z, t) = U(\xi), \quad (3.2.2)$$

where ω is the speed of the traveling wave. The traveling wave transformation (3.2.2) allow them in reducing Eq. (3.2.1) into an ODE for $u = U(\xi)$:

$$H(U, U', U'', U''', U^{(iv)}, U^{(v)}, \dots) = 0, \quad (3.2.3)$$

where H is a polynomial of U and its derivatives and the superscripts indicate the ordinary derivatives with respect to ξ , in which $U'(\xi) = \frac{dU}{d\xi}$.

Step 2: They considered the traveling wave solution of Eq. (3.2.3) can be expressed by a polynomial of $\left(\frac{G'}{G}\right)$ as follows::

$$u(\xi) = \sum_{j=0}^N a_j \left\{ \frac{G'(\xi)}{G(\xi)} \right\}^j, \quad (3.2.4)$$

where $G = G(\xi)$ satisfies the subsequent auxiliary second order linear ordinary differential equation:

$$G''(\xi) + \lambda G'(\xi) + \mu G(\xi) = 0, \quad (3.2.5)$$

where $G' = \frac{dG(\xi)}{d\xi}$, $G'' = \frac{d^2G(\xi)}{d\xi^2}$, a_j ($j = 0, 1, 2, \dots, N$), λ and μ are subjective constants to be determined later, $a_N \neq 0$.

Step 3: To determine the positive integer N , they used homogeneous balance between the highest order nonlinear terms and the derivatives of the highest order involved in (3.2.3).

Step 4: Substitute Eq. (3.2.4) including Eq. (3.2.5) into Eq. (3.2.3) with the value of N attained in Step 3. This leads to a polynomial in $\left(\frac{G'}{G}\right)$ and they collected all terms with the same category of $\left(\frac{G'}{G}\right)$. Setting each coefficient of homologous order of the resulted polynomial to zero, yields a system of algebraic equations for a_j ($j = 0, 1, 2, \dots, N$), λ , μ and ω .

Step 5: The value of the parameters a_j ($j = 0, 1, 2, \dots, N$), λ , μ and ω were established by solving the algebraic equations obtained in Step 4. Since the general solutions of Eq. (3.2.5) are well recognized, inserting the values of the parameters into Eq. (3.2.4) they derived the general exact traveling wave solutions to the NLEE (3.2.1). This completes the determination of solutions of the NLEE (3.2.1) where by means of the general solutions of ODE (3.2.5) one can write the values of $\left(\frac{G'}{G}\right)$ in the following form:

Group 1: When $\lambda^2 - 4\mu > 0$,

$$\frac{G'(\xi)}{G(\xi)} = \frac{-\lambda}{2} + \frac{\sqrt{\lambda^2 - 4\mu}}{2} \left\{ \frac{B \cosh\left(\frac{1}{2}\sqrt{\lambda^2 - 4\mu}\xi\right) + A \sinh\left(\frac{1}{2}\sqrt{\lambda^2 - 4\mu}\xi\right)}{A \cosh\left(\frac{1}{2}\sqrt{\lambda^2 - 4\mu}\xi\right) + B \sinh\left(\frac{1}{2}\sqrt{\lambda^2 - 4\mu}\xi\right)} \right\}. \quad (3.2.6)$$

Group 2: When $\lambda^2 - 4\mu < 0$,

$$\frac{G'(\xi)}{G(\xi)} = \frac{-\lambda}{2} + \frac{\sqrt{4\mu - \lambda^2}}{2} \left\{ \frac{B \cos\left(\frac{1}{2}\sqrt{4\mu - \lambda^2}\xi\right) - A \sin\left(\frac{1}{2}\sqrt{4\mu - \lambda^2}\xi\right)}{A \cos\left(\frac{1}{2}\sqrt{4\mu - \lambda^2}\xi\right) + B \sin\left(\frac{1}{2}\sqrt{4\mu - \lambda^2}\xi\right)} \right\}. \quad (3.2.7)$$

Group 3: When $\lambda^2 - 4\mu = 0$,

$$\frac{G'(\xi)}{G(\xi)} = \frac{-\lambda}{2} + \frac{B}{A + B\xi}, \quad (3.2.8)$$

where A , B , λ and μ are arbitrary constants.

Chapter 4

Applications

Preview Material

➤ 4.1: Applications of the MSE Method

- ✚ 4.1(a): The KdV Equation
- ✚ 4.1(b): The Boussinesq Equation
- ✚ 4.1(c): The Fifth-order KdV equation
- ✚ 4.1(d): The Modified Schamel Equation for Acoustic Waves in Plasma Physics
- ✚ 4.1(e): The Modified Kadomtsev-Petviashvili (KP) Equation for Acoustic Waves in Plasma Physics
- ✚ 4.1(f): The Strain Wave Equation in Microstructured Solids
 - 4.1(f)-I: The Non-dissipative Case
 - 4.1(f)-II: The Dissipative Case

➤ 4.2: Applications of the (G'/G) -expansion Method

- ✚ 4.2(a): The KdV Equation
- ✚ 4.2(b): The Boussinesq Equation
- ✚ 4.2(c): The Fifth-order KdV equation
- ✚ 4.2(d): The Modified Schamel Equation for Acoustic Waves in Plasma Physics
- ✚ 4.2(e): The Modified Kadomtsev-Petviashvili (KP) Equation for Acoustic Waves in Plasma Physics
- ✚ 4.2(f): The Strain Wave Equation in Microstructured Solids
 - 4.2(f)-I: The Non-dissipative Case
 - 4.2(f)-II: The Dissipative Case

In this Chapter, we have implemented the MSE method to solve some NLEEs appearing in applied mathematics, mathematical physics, plasma physics and engineering. In order to compare the solutions obtained by the MSE method, we also refer the solutions of the same equations via the (G'/G) -expansion method, which are previously solved by other researchers (Bekir, 2008; Taha et al., 2013; Wang et al., 2008a; Khan and Akbar, 2015c).

4.1: Applications of the MSE Method

In this section, we have executed the MSE method to extract solitary wave solutions to the KdV equation, the Boussinesq equation, the fifth-order KdV equation, the modified Schamel equation for acoustic waves, the modified Kadomtsev-Petviashvili (KP) equation, the strain wave equation in microstructured solids for non-dissipative and dissipative cases, which are very important NLEEs in the fields of waves on shallow water surfaces, fluid dynamics, shock wave, mass transport, mathematical physics, surface wave propagation in coastal regions, heat and mass transfer, biology, ecology, physiology, crystallization, plasma physics, biological science, nano-science and engineering. The balance number of all of these equations is two. When the balance number of NLEEs is greater than one, typically the MSE method does not provide any solution. Now, we have implemented the technique as to how to execute the MSE method for balance number two which we derived in Chapter 3. If the balance number is two, the solution (3.1.4) takes the following form:

$$U(\xi) = a_0 + a_1 \left(\frac{\psi'}{\psi} \right) + a_2 \left(\frac{\psi'}{\psi} \right)^2, \quad (4.1.1)$$

wherein a_0 , a_1 and a_2 are arbitrary constants to be determined, such that $a_2 \neq 0$, and $\psi(\xi)$ is an unidentified function to be determined later, $\psi'(\xi) \neq 0$.

Differentiating Eq. (4.1.1) with respect to the wave variable ξ , the first to fourth derivatives are given respectively in the following:

$$U' = -\frac{a_1(\psi')^2}{\psi^2} - \frac{2a_2(\psi')^3}{\psi^3} + \frac{a_1\psi''}{\psi} + \frac{2a_2\psi'\psi''}{\psi^2}, \quad (4.1.2)$$

$$U'' = \frac{2a_1(\psi')^3}{\psi^3} + \frac{6a_2(\psi')^4}{\psi^4} - \frac{3a_1\psi'\psi''}{\psi^2} - \frac{10a_2(\psi')^2\psi''}{\psi^3} + \frac{2a_2(\psi'')^2}{\psi^2} \\ + \frac{2a_2\psi'\psi'''}{\psi^2} + \frac{a_1\psi'''}{\psi}, \quad (4.1.3)$$

$$U''' = -\frac{6a_1(\psi')^4}{\psi^4} - \frac{24a_2(\psi')^5}{\psi^5} + \frac{12a_1(\psi')^2\psi''}{\psi^3} + \frac{54a_2(\psi')^3\psi''}{\psi^4} - \frac{3a_1(\psi'')^2}{\psi^2} \\ - \frac{24a_2\psi'(\psi'')^2}{\psi^3} - \frac{4a_1\psi'\psi^{(3)}}{\psi^2} - \frac{14a_2(\psi')^2\psi^{(3)}}{\psi^3} + \frac{6a_2\psi''\psi^{(3)}}{\psi^2} \\ + \frac{a_1\psi^{(4)}}{\psi} + \frac{2a_2\psi'\psi^{(4)}}{\psi^2}, \quad (4.1.4)$$

$$U^{(iv)} = \frac{24a_1(\psi')^5}{\psi^5} + \frac{120a_2(\psi')^6}{\psi^6} - \frac{60a_1(\psi')^3\psi''}{\psi^4} - \frac{336a_2(\psi')^4\psi''}{\psi^5} \\ + \frac{30a_1\psi'(\psi'')^2}{\psi^3} + \frac{234a_2(\psi')^2(\psi'')^2}{\psi^4} - \frac{24a_2(\psi'')^3}{\psi^3} \\ + \frac{20a_1(\psi')^2\psi^{(3)}}{\psi^3} + \frac{96a_2(\psi')^3\psi^{(3)}}{\psi^4} - \frac{10a_1\psi''\psi^{(3)}}{\psi^2} \\ - \frac{88a_2\psi'\psi''\psi^{(3)}}{\psi^3} + \frac{6a_2(\psi^{(3)})^2}{\psi^2} - \frac{5a_1\psi'\psi^{(4)}}{\psi^2} - \frac{18a_2(\psi')^2\psi^{(4)}}{\psi^3} \\ + \frac{8a_2\psi''\psi^{(4)}}{\psi^2} + \frac{a_1\psi^{(5)}}{\psi} + \frac{2a_2\psi'\psi^{(5)}}{\psi^2}, \quad (4.1.5)$$

where primes denote the derivatives, i.e. $U' = \frac{dU(\xi)}{d\xi}$, $U'' = \frac{d^2U(\xi)}{d\xi^2}$, $U''' = \frac{d^3U(\xi)}{d\xi^3}$ and

$$U^{(iv)} = \frac{d^4U(\xi)}{d\xi^4}.$$

4.1(a): The KdV Equation

In this sub-section, our aim is to establish closed-form solitary wave solutions to the KdV equation by means of the MSE method. The KdV equation arises in many mathematical models or physical problems, such as, waves on shallow water surfaces and ion-acoustic

waves in plasma. It is especially significant as the prototype example of an exactly solvable model, that is, a nonlinear partial differential equation whose solutions can be exactly specified. Let us consider the KdV equation in the form:

$$u_t + u u_x + \delta u_{xxx} = 0, \quad (4.1.6)$$

where δ is a real constant.

To construct solitary wave solutions by applying the MSE method to the KdV equation (4.1.6), we use the wave variable as follows:

$$u(x, t) = U(\xi), \quad \xi = x - \omega t. \quad (4.1.7)$$

The traveling wave variable (4.1.7) reduces Eq. (4.1.6) to the following ODE:

$$-\omega U' + U U' + \delta U''' = 0, \quad (4.1.8)$$

where the primes denote the derivatives with respect to ξ . Integrating Eq. (4.1.8) with respect to ξ and letting the integral constant to zero, we obtain a new ODE of the form:

$$-\omega U + \frac{1}{2}U^2 + \delta U'' = 0. \quad (4.1.9)$$

Balancing the highest order derivative U'' and the nonlinear term of the highest order U^2 , we obtain $2N = N + 2 \Rightarrow N = 2$. Therefore, the solution of Eq. (4.1.9) takes the form which is identical to Eq. (4.1.1).

Substituting the values of U and U'' from Eqs. (4.1.1) and (4.1.3) into Eq. (4.1.9), the left-hand side is transformed into a polynomial of $\left(\frac{1}{\psi(\xi)}\right)$. We collect all coefficients of alike power of the resulted polynomial $\left(\frac{1}{\psi(\xi)}\right)^i$, ($i = 0, 1, 2, 3, \dots$) to zero, which yields an over-determine set of algebraic and differential equations for a_i ($i = 0, 1, 2, 3, \dots$), $\psi(\xi)$ and other needful parameters. Therefore, we have the following algebraic and differential equations:

$$\frac{1}{2}a_0(-2\omega + a_0) = 0. \quad (4.1.10)$$

$$a_1\{(-\omega + a_0)\psi' + \delta\psi'''\} = 0. \quad (4.1.11)$$

$$\left\{\frac{1}{2}a_1^2 + a_2(-\omega + a_0)\right\}(\psi')^2 - 3\delta a_1\psi'\psi'' + 2a_2\delta\{(\psi'')^2 + \psi'\psi'''\} = 0. \quad (4.1.12)$$

$$(\psi')^2\{a_1(2\delta + a_2)\psi' - 10\delta a_2\psi''\} = 0. \quad (4.1.13)$$

$$\frac{1}{2}a_2(12\delta + a_2)(\psi')^4 = 0. \quad (4.1.14)$$

We solve the above system of algebraic and differential equations with the help of symbolic computation software, such as, Mathematica. From Eqs. (4.1.10) and (4.1.14), we obtain

$$a_0 = 0, 2\omega$$

and

$$a_2 = -12\delta, \text{ since } a_2 \neq 0.$$

For the values of a_0 , the following cases arise:

Case 1: When $a_0 = 0$.

Now, we have to compute a_1 and $\psi(\xi)$ from the Eqs. (4.1.11) to (4.1.13). To do this, first we have substituted the value of $\psi'(\xi)$ into Eq. (4.1.11) obtained from (4.1.13). After this substitution we will get a third order ODE. To derive the value of $\psi(\xi)$ from this equation we have to integrate twice. In this process we put the second integral constant to zero, otherwise we will get a polynomial of ξ which does not satisfy the condition $|u| \rightarrow 0$ as $\xi \rightarrow \pm\infty$. Thus, from Eqs. (4.1.11) to (4.1.13), we obtain

$$a_1 = \pm 12\sqrt{\delta}\sqrt{\omega}$$

and

$$\psi(\xi) = \frac{\delta c_1}{\omega} e^{\pm \frac{\xi\sqrt{\omega}}{\sqrt{\delta}}} + c_2$$

where c_1 and c_2 are integration constants.

Now, substituting the values of a_0, a_1, a_2 and $\psi(\xi)$ into Eq. (4.1.1), we derive the following solution to the Eq. (4.1.9):

$$U(\xi) = \frac{12\delta\omega^2 c_1 c_2 e^{\pm \frac{\xi\sqrt{\omega}}{\sqrt{\delta}}}}{\left(\delta c_1 e^{\pm \frac{\xi\sqrt{\omega}}{\sqrt{\delta}}} + \omega c_2\right)^2}. \quad (4.1.15)$$

Simplifying the solution (4.1.15), we obtain the subsequent close-form solution to the KdV equation (4.1.6):

$$u(x, t) = (12\delta\omega^2 c_1 c_2) / \left[\delta c_1 \left\{ \cosh\left(\frac{\sqrt{\omega}(x - t\omega)}{2\sqrt{\delta}}\right) \pm \sinh\left(\frac{\sqrt{\omega}(x - t\omega)}{2\sqrt{\delta}}\right) \right\} + \omega c_2 \left\{ \cosh\left(\frac{\sqrt{\omega}(x - t\omega)}{2\sqrt{\delta}}\right) \mp \sinh\left(\frac{\sqrt{\omega}(x - t\omega)}{2\sqrt{\delta}}\right) \right\} \right]^2, \quad (4.1.16)$$

Since c_1 and c_2 are arbitrary constants, one may randomly choose their values. Therefore, if we choose $c_1 = \omega$ and $c_2 = \delta$, then from solution Eq. (4.1.16), we obtain the following bell shape solitary wave solution to the KdV equation:

$$u_{1,1}(x, t) = 3\omega \operatorname{sech}^2\left(\frac{\sqrt{\omega}(x - t\omega)}{2\sqrt{\delta}}\right). \quad (4.1.17)$$

Again, if we choose $c_1 = \omega$ and $c_2 = -\delta$, then from solution Eq. (4.1.16), we obtain the following singular bell shape solitary wave solution to the KdV equation:

$$u_{1,2}(x, t) = -3\omega \operatorname{csch}^2\left(\frac{\sqrt{\omega}(x - t\omega)}{2\sqrt{\delta}}\right). \quad (4.1.18)$$

On the other hand, if we choose $c_1 = \omega$ and $c_2 = \pm i\delta$, then from traveling wave solution (4.1.16), we achieve the following solitary wave solution to the KdV equation:

$$u_{1,3}(x, t) = 3\omega \operatorname{csc}^2\left(\frac{\pi}{4} - \frac{\sqrt{\omega}(x - t\omega)}{2\sqrt{-\delta}}\right). \quad (4.1.19)$$

Furthermore, if we choose $c_1 = \omega$ and $c_2 = \mp i\delta$, then from solution Eq. (4.1.16), we accomplish the following solitary wave solution:

$$u_{1,4}(x, t) = 3\omega \operatorname{csc}^2 \left(\frac{\pi}{4} + \frac{\sqrt{\omega}(x - t\omega)}{2\sqrt{-\delta}} \right). \quad (4.1.20)$$

Case 2: When $a_0 = 2\omega$, we have to follow the same procedure as we have made in Case

1. Therefore, from Eqs. (4.1.11) to (4.1.13), we compute

$$a_1 = \pm 12i\sqrt{\delta}\sqrt{\omega}$$

and

$$\psi(\xi) = -\frac{\delta c_1}{\omega} e^{\pm \frac{i\xi\sqrt{\omega}}{\sqrt{\delta}}} + c_2$$

where c_1 and c_2 are integration constants.

Now, putting the required values of a_0 , a_1 , a_2 and $\psi(\xi)$ into Eq. (4.1.1), we derive the following solution of the Eq. (4.1.9):

$$U(\xi) = \frac{2\omega \left(\delta^2 c_1^2 e^{\pm \frac{2i\xi\sqrt{\omega}}{\sqrt{\delta}}} + 4\delta\omega c_1 c_2 e^{\pm \frac{i\xi\sqrt{\omega}}{\sqrt{\delta}}} + \omega^2 c_2^2 \right)}{\left(e^{\pm \frac{i\xi\sqrt{\omega}}{\sqrt{\delta}}} \delta c_1 - \omega c_2 \right)^2}. \quad (4.1.21)$$

After simplification from solution (4.1.21), we get the subsequent closed-form solution to the KdV equation:

$$\begin{aligned} u(x, t) = & (2\omega) \left[\delta^2 c_1^2 \left\{ \cosh \left(\frac{\sqrt{\omega}(x - t\omega)}{\sqrt{-\delta}} \right) \pm \sinh \left(\frac{\sqrt{\omega}(x - t\omega)}{\sqrt{-\delta}} \right) \right\} + 4\delta\omega c_1 c_2 \right. \\ & \left. + \omega^2 c_2^2 \left\{ \cosh \left(\frac{\sqrt{\omega}(x - t\omega)}{\sqrt{-\delta}} \right) \mp \sinh \left(\frac{\sqrt{\omega}(x - t\omega)}{\sqrt{-\delta}} \right) \right\} \right] \\ & / \left[\delta c_1 \left\{ \cosh \left(\frac{\sqrt{\omega}(x - t\omega)}{\sqrt{-\delta}} \right) \pm \sinh \left(\frac{\sqrt{\omega}(x - t\omega)}{\sqrt{-\delta}} \right) \right\} \right. \\ & \left. - \omega c_2 \left\{ \cosh \left(\frac{\sqrt{\omega}(x - t\omega)}{\sqrt{-\delta}} \right) \mp \sinh \left(\frac{\sqrt{\omega}(x - t\omega)}{\sqrt{-\delta}} \right) \right\} \right]^2. \quad (4.1.22) \end{aligned}$$

As c_1 and c_2 are arbitrary constants, one might arbitrarily pick their values. Therefore, if we pick $c_1 = \omega$ and $c_2 = -\delta$, then from solution Eq. (4.1.22), we attain the following solitary wave solution to the KdV equation:

$$u_{1,5}(x, t) = \omega \left\{ 2 - 3 \operatorname{sech}^2 \left(\frac{\sqrt{\omega}(x - t\omega)}{2\sqrt{-\delta}} \right) \right\}. \quad (4.1.23)$$

On the other hand, if we pick $c_1 = \omega$ and $c_2 = \delta$, then from solution Eq. (4.1.22), we achieve the subsequent solitary solution to the KdV equation:

$$u_{1,6}(x, t) = \omega \left\{ 2 + 3 \operatorname{csch}^2 \left(\frac{\sqrt{\omega}(x - t\omega)}{2\sqrt{-\delta}} \right) \right\}. \quad (4.1.24)$$

Alternatively, if we pick $c_1 = \omega$ and $c_2 = \pm i\delta$, then from solution Eq. (4.1.22), we obtain the succeeding solution to the KdV equation:

$$u_{1,7}(x, t) = \omega \left\{ 2 - 3 \operatorname{csc}^2 \left(\frac{\pi}{4} - \frac{\sqrt{\omega}(x - t\omega)}{2\sqrt{\delta}} \right) \right\}. \quad (4.1.25)$$

Once again, if we pick $c_1 = \omega$ and $c_2 = \mp i\delta$, then from solution Eq. (4.1.22), we derive the next solitary solution to the KdV equation:

$$u_{1,8}(x, t) = \omega \left\{ 2 - 3 \operatorname{csc}^2 \left(\frac{\pi}{4} + \frac{\sqrt{\omega}(x - t\omega)}{2\sqrt{\delta}} \right) \right\}. \quad (4.1.26)$$

Since c_1 and c_2 are arbitrary constants for other choices of c_1 and c_2 , we might obtain new and more general solitary wave solutions to the KdV equation (4.1.6) by using the MSE method with the aid of symbolic computation software. The major advantage of this method is that the calculations are easy to control, not sophisticated. Its calculations are comparatively easier than other methods, like, the Exp-function method, the (G'/G) -expansion method, the tanh-function method, the homotopy analysis method etc. But the solutions obtained by the MSE method are analogous to those solutions obtained by the above mentioned method.

Remark 4.1(a): Solutions (4.1.16)-(4.1.20) and (4.1.22)-(4.1.26) have been verified by putting them back into the original equation (4.1.6) and found correct.

4.1(b): The Boussinesq Equation

In this sub-section, we have executed the application of the MSE method to extract solitary wave solutions to the Boussinesq equation, which is a very important equation in the fields of surface wave propagation in coastal regions, heat and mass transfer, biology, ecology, crystallization, plasma physics. Now, we have applied the MSE method to find the exact solutions and then the solitary wave solutions to the Boussinesq equation. Let us consider the Boussinesq equation in the form:

$$u_{tt} - u_{xx} - (u^2)_{xx} + u_{xxxx} = 0. \quad (4.1.27)$$

To solve the Boussinesq equation (4.1.27) by applying the MSE method, we will make use of the same wave variable given in (4.1.7):

Using the wave variable (4.1.7), the Eq. (4.1.27) transforms to the following ODE:

$$(\omega^2 - 1)U'' - (U^2)'' + U^{(iv)} = 0, \quad (4.1.28)$$

where primes indicate the derivatives with respect to ξ . Integrating Eq. (4.1.28) twice with respect to ξ and letting the integral constants to zero, we find an ODE in the form:

$$(\omega^2 - 1)U - U^2 + U'' = 0. \quad (4.1.29)$$

The homogeneous balance between the highest order derivative U'' and the nonlinear term of the highest order U^2 , yields $N = 2$. Thus, the solution of Eq. (4.1.29) takes the form, identical to (4.1.1).

Substituting the values of U and U'' from the Eqs. (4.1.1) and (4.1.3) into Eq. (4.1.29), and executing the parallel course of algorithm discussed in Sub-section 4.1(a) yields a set of simultaneous algebraic and differential equations for $a_0, a_1, a_2, \psi(\xi)$ and additional essential parameters, which are given in the following:

$$(-1 + \omega^2 - a_0)a_0 = 0. \quad (4.1.30)$$

$$a_1\{(-1 + \omega^2 - 2a_0)\psi' + \psi'''\} = 0. \quad (4.1.31)$$

$$\{a_2(-1 + \omega^2 - 2a_0) - a_1^2\}(\psi')^2 - 3a_1\psi'\psi'' + 2a_2\{(\psi'')^2 + \psi'\psi'''\} = 0. \quad (4.1.32)$$

$$-2(\psi')^2(a_1(-1 + a_2)\psi' + 5a_2\psi'') = 0. \quad (4.1.33)$$

$$-(-6 + a_2)a_2(\psi')^4 = 0. \quad (4.1.34)$$

Solving Eq. (4.1.30), we obtain

$$a_0 = 0, \quad -1 + \omega^2.$$

Again solving Eq. (4.1.34), we obtain

$$a_2 = 6 \text{ since } a_2 \neq 0.$$

Therefore, for the values of a_0 , the following two cases arise:

Case 1: When $a_0 = 0$, we have to take in the same procedure as we have took in section 4.1(a). Therefore, from Eqs. (4.1.31) to (4.1.33), we compute

$$a_1 = \pm 6\sqrt{1 - \omega^2}$$

and

$$\psi(\xi) = \frac{-c_1 e^{\mp \xi \sqrt{1 - \omega^2}} \mp (-1 + \omega^2)c_2}{-1 + \omega^2}$$

where c_1 and c_2 are integration constants.

By means of the values of a_0, a_1, a_2 and $\psi(\xi)$, from Eq. (4.1.1), we obtain the following solution to the Eq. (4.1.29):

$$U(\xi) = -\frac{6(-1 + \omega^2)^2 c_1 c_2 e^{\mp \xi \sqrt{1 - \omega^2}}}{(c_1 e^{\mp \xi \sqrt{1 - \omega^2}} - (-1 + \omega^2)c_2)^2}. \quad (4.1.35)$$

After simplification from the solution (4.1.35), we obtain the subsequent solution to the Boussinesq equation (4.1.27):

$$\begin{aligned}
u(x, t) = & -\{6(-1 + \omega^2)^2 c_1 c_2\} \\
& / \left[c_1 \left\{ \cosh \left(\frac{(x - t\omega)\sqrt{1 - \omega^2}}{2} \right) \mp \sinh \left(\frac{(x - t\omega)\sqrt{1 - \omega^2}}{2} \right) \right\} \right. \\
& - (-1 + \omega^2) c_2 \left\{ \cosh \left(\frac{(x - t\omega)\sqrt{1 - \omega^2}}{2} \right) \right. \\
& \left. \left. \pm \sinh \left(\frac{(x - t\omega)\sqrt{1 - \omega^2}}{2} \right) \right\} \right]^2. \tag{4.1.36}
\end{aligned}$$

Since c_1 and c_2 are arbitrary constants, we may freely select their values. Therefore, if we select $c_1 = (1 - \omega^2)$ and $c_2 = 1$, then from (4.1.36), we obtain the following bell shape solitary wave solution to the Boussinesq equation:

$$u_{1,9}(x, t) = \frac{3}{2}(-1 + \omega^2) \operatorname{sech}^2 \left(\frac{\sqrt{1 - \omega^2}(x - t\omega)}{2} \right). \tag{4.1.37}$$

Furthermore, if we select $c_1 = -(1 - \omega^2)$ and $c_2 = 1$, then from solution (4.1.36) we accomplish the subsequent singular bell shape solitary wave solution to the Boussinesq equation:

$$u_{1,10}(x, t) = -\frac{3}{2}(-1 + \omega^2) \operatorname{csch}^2 \left(\frac{\sqrt{1 - \omega^2}(x - t\omega)}{2} \right). \tag{4.1.38}$$

Again, if we select $c_1 = (-1 + \omega^2)$ and $c_2 = \pm i$, then from solution (4.1.36), we obtain the succeeding solitary wave solution to the Boussinesq equation:

$$u_{1,11}(x, t) = \frac{3}{2}(-1 + \omega^2) \operatorname{csc}^2 \left(\frac{\pi}{4} + \frac{1}{2}(x - t\omega)\sqrt{-1 + \omega^2} \right). \tag{4.1.39}$$

Alternatively, if we select $c_1 = (-1 + \omega^2)$ and $c_2 = \mp i$, then from solution (4.1.36), we get the next solitary wave solution to the Boussinesq equation:

$$u_{1,12}(x, t) = \frac{3}{2}(-1 + \omega^2) \operatorname{csc}^2 \left(\frac{\pi}{4} - \frac{1}{2}(x - t\omega)\sqrt{-1 + \omega^2} \right). \tag{4.1.40}$$

Case 2: When $a_0 = -1 + \omega^2$, we have to take in the same procedure as we have took in section 4.1(a). Therefore, from Eqs. (4.1.31) to (4.1.33), we get

$$a_1 = \pm 6\sqrt{-1 + \omega^2}$$

and

$$\psi(\xi) = \frac{c_1}{-1+\omega^2} e^{\mp \xi \sqrt{-1+\omega^2}} + c_2$$

where c_1 and c_2 are constants integration.

Inserting the values of a_0 , a_1 , a_2 and $\psi(\xi)$ into Eq. (4.1.1), we extract the following solution to the Eq. (4.1.29):

$$U(\xi) = -1 + \omega^2 - \frac{6(-1 + \omega^2)^2 c_1 c_2 e^{\pm \xi \sqrt{-1+\omega^2}}}{\{c_1 + (-1 + \omega^2) c_2 e^{\pm \xi \sqrt{-1+\omega^2}}\}^2}. \quad (4.1.41)$$

Expanding the solution (4.1.41), we obtain the following close-form solution to the Boussinesq equation (4.1.27) :

$$\begin{aligned} u(x, t) = & (\omega^2 - 1) \left[c_1^2 \left\{ \cosh \left((x - t\omega) \sqrt{\omega^2 - 1} \right) \mp \sinh \left((x - t\omega) \sqrt{\omega^2 - 1} \right) \right\} \right. \\ & + (\omega^2 - 1)^2 c_2^2 \left\{ \cosh \left((x - t\omega) \sqrt{\omega^2 - 1} \right) \right. \\ & \left. \left. \pm \sinh \left((x - t\omega) \sqrt{\omega^2 - 1} \right) \right\} - 4(\omega^2 - 1) c_1 c_2 \right] \\ & / \left[c_1 \left\{ \cosh \left(\frac{(x - t\omega) \sqrt{\omega^2 - 1}}{2} \right) \mp \sinh \left(\frac{(x - t\omega) \sqrt{\omega^2 - 1}}{2} \right) \right\} \right. \\ & + (\omega^2 - 1) c_2 \left\{ \cosh \left(\frac{(x - t\omega) \sqrt{\omega^2 - 1}}{2} \right) \right. \\ & \left. \left. \pm \sinh \left(\frac{(x - t\omega) \sqrt{\omega^2 - 1}}{2} \right) \right\} \right]^2. \quad (4.1.42) \end{aligned}$$

One may intuitively choose the values of c_1 and c_2 because, they are arbitrary constants. Thus, if we choose $c_1 = (\omega^2 - 1)$ and $c_2 = 1$, then from (4.1.42), we derive the following bell shape solitary wave solution to the Boussinesq equation:

$$u_{1,13}(x, t) = (-1 + \omega^2) \left\{ 1 - \frac{3}{2} \operatorname{sech}^2 \left(\frac{1}{2} (x - t\omega) \sqrt{-1 + \omega^2} \right) \right\}. \quad (4.1.43)$$

On the other hand, if we choose $c_1 = (\omega^2 - 1)$ and $c_2 = -1$, then from solution (4.1.42), we find out the following singular bell shape solitary wave solution to the Boussinesq equation:

$$u_{1,14}(x, t) = (-1 + \omega^2) \left\{ 1 + \frac{3}{2} \operatorname{csch}^2 \left(\frac{1}{2} (x - t\omega) \sqrt{-1 + \omega^2} \right) \right\}. \quad (4.1.44)$$

Again, if we choose $c_1 = (\omega^2 - 1)$ and $c_2 = \pm i$, then from solution (4.1.42), we attain the subsequent solitary wave solution to the Boussinesq equation:

$$u_{1,15}(x, t) = (-1 + \omega^2) \left\{ 1 - \frac{3}{2} \operatorname{csc}^2 \left(\frac{\pi}{4} - \frac{1}{2} (x - t\omega) \sqrt{1 - \omega^2} \right) \right\}. \quad (4.1.45)$$

Once again, if we choose $c_1 = (\omega^2 - 1)$ and $c_2 = \mp i$, then from solution (4.1.42), we secure the next solitary wave solution to the Boussinesq equation:

$$u_{1,16}(x, t) = (-1 + \omega^2) \left(1 - \frac{3}{2} \operatorname{csc}^2 \left[\frac{\pi}{4} + \frac{1}{2} (x - t\omega) \sqrt{1 - \omega^2} \right] \right). \quad (4.1.46)$$

For other choices of c_1 and c_2 , we might find further new and more general solitary wave solutions to the Boussinesq equation (4.1.27) by using the MSE method, because c_1 and c_2 are arbitrary constants.

Remark 4.1(b): The wave solutions (4.1.37)-(4.1.41) and (4.1.42)-(4.1.46) have been confirmed by putting them back into the original equation (4.1.27) and found accurate.

4.1(c): The Fifth-order KdV Equation

In this sub-section, we have performed the MSE method to extract traveling wave solutions to the fifth-order KdV equation which is a very important equation in the field of surface wave propagation on shallow water surfaces. Let us consider the fifth-order KdV equation of the form:

$$u_t + \alpha u u_x + \beta u^2 u_x + \gamma u_{xxx} + \mu u_{xxxxx} = 0, \quad (4.1.47)$$

where α , β , γ and μ are real parameters.

Now we have investigated exact solitary wave solutions to the fifth-order KdV equation (4.1.47) by means of the MSE method. On account of this, we will use the wave variable provided in Eq. (4.1.7). The traveling wave variable (4.1.7) reduces Eq. (4.1.47) to the following ODE:

$$(-\omega + \alpha U + \beta U^2)U' + \gamma U''' + \mu U^{(v)} = 0, \quad (4.1.48)$$

where the primes signify the derivatives with respect to ξ . Integrating Eq. (4.1.48) with respect to ξ and letting the integral constant to zero, we find a new ODE in the form:

$$-\omega U + \alpha \frac{U^2}{2} + \beta \frac{U^3}{3} + \gamma U'' + \mu U^{(iv)} = 0. \quad (4.1.49)$$

Now, the homogeneous balance between the highest order derivative $U^{(iv)}$ and the nonlinear term of the highest order U^3 , yields $N = 2$. Therefore, the shape of the solution of Eq. (4.1.49) is look like Eq. (4.1.1), wherein a_0 , a_1 and a_2 are arbitrary constants to be determined such that $a_2 \neq 0$ and $\psi(\xi)$ is an unidentified function.

Putting the values of U , U' , U'' , U''' and $U^{(iv)}$, from Eqs. (4.1.1)-(4.1.5) into Eq. (4.1.49), and executing the same algorithm discussed in Sub-section 4.1(a) yields a set of simultaneous algebraic and differential equations for a_0 , a_1 , a_2 , $\psi(\xi)$ and additional essential parameters, which are given below:

$$\frac{1}{6}a_0(-6\omega + 3\alpha a_0 + 2\beta a_0^2) = 0. \quad (4.1.50)$$

$$a_1 \left((-\omega + \alpha a_0 + \beta a_0^2)\psi' + \gamma\psi''' + \mu\psi^{(v)} \right) = 0. \quad (4.1.51)$$

$$\begin{aligned} & \frac{1}{2}(\alpha + 2\beta a_0)a_1^2(\psi')^2 - a_1 \left(10\mu\psi''\psi''' + \psi'(3\gamma\psi'' + 5\mu\psi^{(iv)}) \right) \\ & + a_2 \left((-\omega + \alpha a_0 + \beta a_0^2)(\psi')^2 + 2\gamma(\psi'')^2 + 6\mu(\psi''')^2 + 8\mu\psi''\psi^{(iv)} \right. \\ & \left. + 2\psi'(\gamma\psi''' + \mu\psi^{(v)}) \right) = 0. \end{aligned} \quad (4.1.52)$$

$$\begin{aligned}
& a_1 \psi' \left((2\gamma + (\alpha + 2\beta a_0) a_2) (\psi')^2 + 30\mu (\psi'')^2 + 20\mu \psi' \psi''' \right) \\
& \quad - 2a_2 \left(12\mu (\psi'')^3 + 44\mu \psi' \psi'' \psi''' + (\psi')^2 (5\gamma \psi'' + 9\mu \psi^{(iv)}) \right) \\
& \quad + \frac{1}{3} \beta a_1^3 (\psi')^3 = 0.
\end{aligned} \tag{4.1.53}$$

$$\begin{aligned}
& a_2 (\psi')^2 \left((6\gamma + \beta a_1^2) (\psi')^2 + 234\mu (\psi'')^2 + 96\mu \psi' \psi''' \right) + \frac{1}{2} (\alpha + 2\beta a_0) a_2^2 (\psi')^4 \\
& \quad - 60\mu a_1 (\psi')^3 \psi'' = 0.
\end{aligned} \tag{4.1.54}$$

$$(\psi')^4 (a_1 (24\mu + \beta a_2^2) \psi' - 336\mu a_2 \psi'') = 0. \tag{4.1.55}$$

$$\frac{1}{3} a_2 (360\mu + \beta a_2^2) (\psi')^6 = 0. \tag{4.1.56}$$

Solving Eq. (4.1.50) and (4.1.56), we obtain

$$a_0 = 0, \quad \frac{-3\alpha \pm \sqrt{3}\sqrt{3\alpha^2 + 16\beta\omega}}{4\beta}$$

And

$$a_2 = \pm \frac{6i\sqrt{10}\sqrt{\mu}}{\sqrt{\beta}}, \quad \text{since } a_2 \neq 0.$$

When $a_0 = \frac{-3\alpha \pm \sqrt{3}\sqrt{3\alpha^2 + 16\beta\omega}}{4\beta}$, then the extracted values of a_1 , $\psi(\xi)$ and the required solutions are very much unsmooth and odd looking. So, we have overridden this case and discussed only the case $a_0 = 0$.

Therefore, for the values of a_2 , the following two cases arise:

Case 1: When $a_2 = \frac{6i\sqrt{10}\sqrt{\mu}}{\sqrt{\beta}}$, then by a suitable manipulation, from Eqs. (4.1.51) to

(4.1.55), we compute

$$a_1 = \pm \frac{6\sqrt{2\sqrt{\beta}\gamma + i\sqrt{10}\alpha\sqrt{\mu}}}{\beta^{\frac{3}{4}}},$$

$$\omega = -\frac{8\beta\gamma^2 + 3i\sqrt{10}\alpha\sqrt{\beta\gamma\sqrt{\mu}} + 5\alpha^2\mu}{50\beta\mu}$$

and

$$\psi(\xi) = \mp \frac{i\sqrt{10}\beta^{\frac{1}{4}}\sqrt{\mu}c_1}{\sqrt{2\sqrt{\beta\gamma} + i\sqrt{10}\alpha\sqrt{\mu}}} e^{\pm \frac{i\sqrt{2\sqrt{\beta\gamma} + i\sqrt{10}\alpha\sqrt{\mu}} \xi}{\sqrt{10}\beta^{\frac{1}{4}}\sqrt{\mu}}} + c_2$$

where c_1 and c_2 are integration constants.

By using the values of a_0 , a_1 , a_2 and $\psi(\xi)$ from Eq. (4.1.1), we obtain the following closed-form solution:

$$U(\xi) = \pm \frac{6(2\sqrt{\beta\gamma} + i\sqrt{10}\alpha\sqrt{\mu})^{\frac{3}{2}}\beta^{-\frac{3}{4}}c_1c_2 e^{\pm \frac{i\sqrt{2\sqrt{\beta\gamma} + i\sqrt{10}\alpha\sqrt{\mu}} \xi}{\sqrt{10}\beta^{\frac{1}{4}}\sqrt{\mu}}}}{\left(\sqrt{2\sqrt{\beta\gamma} + i\sqrt{10}\alpha\sqrt{\mu}}c_2 \mp i\sqrt{10}\beta^{\frac{1}{4}}\sqrt{\mu}c_1 e^{\pm \frac{i\sqrt{2\sqrt{\beta\gamma} + i\sqrt{10}\alpha\sqrt{\mu}} \xi}{\sqrt{10}\beta^{\frac{1}{4}}\sqrt{\mu}}} \right)^2}. \quad (4.1.57)$$

Simplifying the solution (4.1.57), we find the following solution to the fifth-order KdV equation (4.1.47):

$$\begin{aligned} u(x, t) = & \mp \left\{ 6(2\sqrt{\beta\gamma} + i\sqrt{10}\alpha\sqrt{\mu})^{\frac{3}{2}}\beta^{-\frac{3}{4}}c_1c_2 \right\} \\ & / \left\{ \left(\pm i\sqrt{2\sqrt{\beta\gamma} + i\sqrt{10}\alpha\sqrt{\mu}}c_2 + \sqrt{10}\beta^{\frac{1}{4}}\sqrt{\mu}c_1 \right) \cos((x - t\rho_1) h_1) \right. \\ & + \left(\sqrt{2\sqrt{\beta\gamma} + i\sqrt{10}\alpha\sqrt{\mu}}c_2 \right. \\ & \left. \left. \pm i\sqrt{10}\beta^{\frac{1}{4}}\sqrt{\mu}c_1 \right) \sin((x - t\rho_1) h_1) \right\}^2, \end{aligned} \quad (4.1.58)$$

where $\rho_1 = -\frac{8\beta\gamma^2 - 3\sqrt{10}\alpha\sqrt{\beta\gamma\sqrt{-\mu}} + 5\alpha^2\mu}{50\beta\mu}$ and $h_1 = \frac{\sqrt{2\sqrt{\beta\gamma} - \sqrt{10}\alpha\sqrt{-\mu}}}{2\sqrt{10}\beta^{\frac{1}{4}}\sqrt{\mu}}$. Forasmuch as c_1 and

c_2 are integration constants, one may arbitrarily opt their values. Therefore, if we opt

$c_1 = \sqrt{2\sqrt{\beta\gamma} + i\sqrt{10}\alpha\sqrt{\mu}}$ and $c_2 = \mp i\sqrt{10}\beta^{1/4}\sqrt{\mu}$, then from Eq. (4.1.58), we extract

the following solution to the fifth-order KdV equation:

$$u_{1,17}(x, t) = -\frac{3(5\alpha\sqrt{\mu} + \sqrt{10}\sqrt{-\beta\gamma})}{10\beta\sqrt{\mu}} \times \left\{ 1 - \tanh^2 \left(\frac{(x - t\rho_1)\sqrt{2\sqrt{\beta\gamma} - \sqrt{10}\alpha\sqrt{-\mu}}}{2\sqrt{10}\beta^{\frac{1}{4}}\sqrt{-\mu}} \right) \right\}, \quad (4.1.59)$$

where $\rho_1 = -\frac{8\beta\gamma^2 - 3\sqrt{10}\alpha\sqrt{\beta\gamma\sqrt{-\mu}} + 5\alpha^2\mu}{50\beta\mu}$.

Again, if we opt $c_1 = \sqrt{2\sqrt{\beta\gamma} + i\sqrt{10}\alpha\sqrt{\mu}}$ and $c_2 = \pm i\sqrt{10}\beta^{1/4}\sqrt{\mu}$, then from solution (4.1.58), we extract the subsequent solitary wave solution to the fifth-order KdV equation:

$$u_{1,18}(x, t) = -\frac{3(5\alpha\sqrt{\mu} + \sqrt{10}\sqrt{-\beta\gamma})}{10\beta\sqrt{\mu}} \times \left\{ 1 - \coth^2 \left(\frac{(x - t\rho_1)\sqrt{2\sqrt{\beta\gamma} - \sqrt{10}\alpha\sqrt{-\mu}}}{2\sqrt{10}\beta^{\frac{1}{4}}\sqrt{-\mu}} \right) \right\}, \quad (4.1.60)$$

where $\rho_1 = -\frac{8\beta\gamma^2 - 3\sqrt{10}\alpha\sqrt{\beta\gamma\sqrt{-\mu}} + 5\alpha^2\mu}{50\beta\mu}$.

Once again, if we opt $c_1 = \sqrt{2\sqrt{\beta\gamma} + i\sqrt{10}\alpha\sqrt{\mu}}$ and $c_2 = \sqrt{10}\beta^{1/4}\sqrt{\mu}$, then from exact solution (4.1.58), we accomplish the subsequent solitary wave solution to the fifth-order KdV equation:

$$u_{1,19}(x, t) = \frac{3(-2\beta\gamma^2 + 5\alpha^2\mu + 2\sqrt{10}\alpha\sqrt{-\beta\gamma\sqrt{\mu}})}{-\sqrt{10}\beta(2\sqrt{-\beta\gamma} + \sqrt{10}\alpha\sqrt{\mu})\sqrt{\mu}} \times \csc^2 \left(\frac{\pi}{4} + \frac{(x - t\rho_1)\sqrt{2\sqrt{\beta\gamma} - \sqrt{10}\alpha\sqrt{-\mu}}}{2\sqrt{10}\beta^{\frac{1}{4}}\sqrt{\mu}} \right), \quad (4.1.61)$$

where $\rho_1 = -\frac{8\beta\gamma^2 - 3\sqrt{10}\alpha\sqrt{\beta\gamma\sqrt{-\mu}} + 5\alpha^2\mu}{50\beta\mu}$.

Furthermore, if we opt $c_1 = \sqrt{2\sqrt{\beta\gamma} + i\sqrt{10}\alpha\sqrt{\mu}}$ and $c_2 = -\sqrt{10}\beta^{1/4}\sqrt{\mu}$, then from solution (4.1.58), we derive the next solitary wave solution to the fifth-order KdV equation:

$$u_{1,20}(x, t) = \frac{3(-2\beta\gamma^2 + 5\alpha^2\mu + 2\sqrt{10}\alpha\sqrt{-\beta\gamma\sqrt{\mu}})}{-\sqrt{10}\beta(2\sqrt{-\beta\gamma} + \sqrt{10}\alpha\sqrt{\mu})\sqrt{\mu}} \times \text{csc}^2\left(\frac{\pi}{4} - \frac{(x - t\rho_1)\sqrt{2\sqrt{\beta\gamma} - \sqrt{10}\alpha\sqrt{-\mu}}}{2\sqrt{10}\beta^{1/4}\sqrt{\mu}}\right), \quad (4.1.62)$$

where $\rho_1 = -\frac{8\beta\gamma^2 - 3\sqrt{10}\alpha\sqrt{\beta\gamma\sqrt{-\mu}} + 5\alpha^2\mu}{50\beta\mu}$.

Case 2: When $a_2 = -\frac{6i\sqrt{10}\sqrt{\mu}}{\sqrt{\beta}}$, then by a appropriate treatment, from Eqs. (4.1.51) to (4.1.55), we compute

$$a_1 = \pm \frac{6\sqrt{2\sqrt{\beta\gamma} - i\sqrt{10}\alpha\sqrt{\mu}}}{\beta^{3/4}},$$

$$\omega = -\frac{8\beta\gamma^2 - 3i\sqrt{10}\alpha\sqrt{\beta\gamma\sqrt{\mu}} + 5\alpha^2\mu}{50\beta\mu}$$

and

$$\psi(\xi) = \pm \frac{i\sqrt{10}\beta^{1/4}\sqrt{\mu}c_1}{\sqrt{2\sqrt{\beta\gamma} - i\sqrt{10}\alpha\sqrt{\mu}}} e^{\mp \frac{i\sqrt{2\sqrt{\beta\gamma} - i\sqrt{10}\alpha\sqrt{\mu}}\xi}{\sqrt{10}\beta^{1/4}\sqrt{\mu}}} + c_2$$

where c_1 and c_2 are constants of integration.

Putting the values of a_0 , a_1 , a_2 and $\psi(\xi)$ into Eq. (4.1.1), we obtain the following general solution to the Eq. (4.1.49):

$$U(\xi) = \pm \frac{6(2\sqrt{\beta\gamma} - i\sqrt{10}\alpha\sqrt{\mu})^{\frac{3}{2}}\beta^{-\frac{3}{4}}c_1c_2e^{\mp \frac{i\sqrt{2\sqrt{\beta\gamma} - i\sqrt{10}\alpha\sqrt{\mu}}\xi}{\sqrt{10}\beta^{\frac{1}{4}}\sqrt{\mu}}}}{\left(\sqrt{2\sqrt{\beta\gamma} - i\sqrt{10}\alpha\sqrt{\mu}}c_2 \pm i\sqrt{10}\beta^{\frac{1}{4}}\sqrt{\mu}c_1e^{\mp \frac{i\sqrt{2\sqrt{\beta\gamma} - i\sqrt{10}\alpha\sqrt{\mu}}\xi}{\sqrt{10}\beta^{\frac{1}{4}}\sqrt{\mu}}}}\right)^2}. \quad (4.1.63)$$

Simplifying the solution (4.1.63), we establish the subsequent close-form solution to the fifth-order KdV equation (4.1.47):

$$u(x, t) = \mp \left\{ 6(2\sqrt{\beta\gamma} - i\sqrt{10}\alpha\sqrt{\mu})^{\frac{3}{2}}\beta^{-\frac{3}{4}}c_1c_2 \right. \\ \left. / \left\{ \left(\mp i\sqrt{2\sqrt{\beta\gamma} - i\sqrt{10}\alpha\sqrt{\mu}}c_2 + \sqrt{10}\beta^{\frac{1}{4}}\sqrt{\mu}c_1 \right) \cos((x - t\rho_2)h_2) \right. \right. \\ \left. \left. + \left(\sqrt{2\sqrt{\beta\gamma} - i\sqrt{10}\alpha\sqrt{\mu}}c_2 \right. \right. \right. \\ \left. \left. \left. \mp i\sqrt{10}\beta^{\frac{1}{4}}\sqrt{\mu}c_1 \right) \sin((x - t\rho_2)h_2) \right\}^2 \right\}, \quad (4.1.64)$$

$$\text{where, } \rho_2 = -\frac{8\beta\gamma^2 + 3\sqrt{10}\alpha\sqrt{\beta\gamma}\sqrt{-\mu} + 5\alpha^2\mu}{50\beta\mu} \text{ and } h_2 = \frac{\sqrt{2\sqrt{\beta\gamma} + \sqrt{10}\alpha\sqrt{-\mu}}}{2\sqrt{10}\beta^{\frac{1}{4}}\sqrt{\mu}}.$$

Now, one may arbitrarily put the values of c_1 and c_2 , because they are arbitrary constants.

Therefore, if we put $c_1 = \sqrt{2\sqrt{\beta\gamma} - i\sqrt{10}\alpha\sqrt{\mu}}$ and $c_2 = \pm i\sqrt{10}\beta^{1/4}\sqrt{\mu}$, then from Eq.

(4.1.64), we get the following solution to the fifth-order KdV equation:

$$u_{1,21}(x, t) = -\frac{3(5\alpha\sqrt{\mu} - \sqrt{10}\sqrt{-\beta\gamma})}{10\beta\sqrt{\mu}} \\ \times \operatorname{sech}^2 \left(\frac{(x - t\rho_2)\sqrt{2\sqrt{\beta\gamma} + \sqrt{10}\alpha\sqrt{-\mu}}}{2\sqrt{10}\beta^{\frac{1}{4}}\sqrt{-\mu}} \right), \quad (4.1.65)$$

$$\text{where } \rho_2 = -\frac{8\beta\gamma^2 + 3\sqrt{10}\alpha\sqrt{\beta\gamma}\sqrt{-\mu} + 5\alpha^2\mu}{50\beta\mu}.$$

Alternatively, if we put $c_1 = \sqrt{2\sqrt{\beta\gamma} - i\sqrt{10}\alpha\sqrt{\mu}}$ and $c_2 = \mp i\sqrt{10}\beta^{1/4}\sqrt{\mu}$, then from solution (4.1.64), we derive the following wave solution to the fifth-order KdV equation:

$$u_{1,22}(x, t) = \frac{3(5\alpha\sqrt{\mu} - \sqrt{10}\sqrt{-\beta\gamma})}{10\beta\sqrt{\mu}} \times \operatorname{csch}^2 \left(\frac{(x - t\rho_2)\sqrt{2\sqrt{\beta\gamma} + \sqrt{10}\alpha\sqrt{-\mu}}}{2\sqrt{10}\beta^{1/4}\sqrt{\mu}} \right), \quad (4.1.66)$$

$$\text{where } \rho_2 = -\frac{8\beta\gamma^2 + 3\sqrt{10}\alpha\sqrt{\beta\gamma}\sqrt{-\mu} + 5\alpha^2\mu}{50\beta\mu}.$$

On the other hand, if we put $c_1 = \sqrt{2\sqrt{\beta\gamma} + \sqrt{10}\alpha\sqrt{-\mu}}$ and $c_2 = \sqrt{10}\beta^{1/4}\sqrt{\mu}$, then from solution (4.1.64), we achieve the subsequent solitary wave solution to the fifth-order KdV equation:

$$u_{1,23}(x, t) = \frac{3(2\sqrt{10}\alpha\sqrt{-\beta\gamma}\sqrt{\mu} + 2\beta\gamma^2 - 5\alpha^2\mu)}{-\sqrt{10}\beta(2\sqrt{-\beta\gamma} - \sqrt{10}\alpha\sqrt{\mu})\sqrt{\mu}} \times \operatorname{csc}^2 \left(\frac{\pi}{4} + \frac{(x - t\rho_2)\sqrt{2\sqrt{\beta\gamma} + \sqrt{10}\alpha\sqrt{-\mu}}}{2\sqrt{10}\beta^{1/4}\sqrt{\mu}} \right), \quad (4.1.67)$$

$$\text{where } \rho_2 = -\frac{8\beta\gamma^2 + 3\sqrt{10}\alpha\sqrt{\beta\gamma}\sqrt{-\mu} + 5\alpha^2\mu}{50\beta\mu}.$$

Again, if we put $c_1 = \sqrt{2\sqrt{\beta\gamma} - i\sqrt{10}\alpha\sqrt{\mu}}$ and $c_2 = -\sqrt{10}\beta^{1/4}\sqrt{\mu}$, then from solution (4.1.64), we find out the succeeding solitary wave solution to the fifth-order KdV equation:

$$u_{1,24}(x, t) = \frac{3(2\sqrt{10}\alpha\sqrt{-\beta\gamma}\sqrt{\mu} + 2\beta\gamma^2 - 5\alpha^2\mu)}{-\sqrt{10}\beta(2\sqrt{-\beta\gamma} - \sqrt{10}\alpha\sqrt{\mu})\sqrt{\mu}} \times \operatorname{csc}^2 \left(\frac{\pi}{4} - \frac{(x - t\rho_2)\sqrt{2\sqrt{\beta\gamma} + \sqrt{10}\alpha\sqrt{-\mu}}}{2\sqrt{10}\beta^{1/4}\sqrt{\mu}} \right), \quad (4.1.68)$$

where $\rho_2 = -\frac{8\beta\gamma^2+3\sqrt{10}\alpha\sqrt{\beta\gamma\sqrt{-\mu}+5\alpha^2\mu}}{50\beta\mu}$.

Since c_1 and c_2 are arbitrary constants, one might choose their values in different ways and each choice yields more general, efficient and accessible solutions to the fifth-order KdV equation in compact form. But to avoid monotony the residual solutions have not been recorded.

Remark 4.1(c): The solutions (4.1.58)-(4.1.62), where $\rho_1 = -\frac{8\beta\gamma^2-3\sqrt{10}\alpha\sqrt{\beta\gamma\sqrt{-\mu}+5\alpha^2\mu}}{50\beta\mu}$

and the solutions (4.1.64)-(4.1.68), where $\rho_2 = -\frac{8\beta\gamma^2+3\sqrt{10}\alpha\sqrt{\beta\gamma\sqrt{-\mu}+5\alpha^2\mu}}{50\beta\mu}$ have been

confirmed by putting them back into the original equation (4.1.47) and the validity has been established.

4.1(d): The Modified Schamel Equation for Acoustic Waves in Plasma Physics

In this sub-section, we have carried through the MSE method to extract solitary wave solutions to the modified Schamel equation concerned to acoustic waves, which is very important in plasma physics. Our aim is to examine some new solitary wave solutions to this equation by the MSE method. Let us consider the NLEEs establish by Schamel for acoustic waves in plasma physics (Taha et al., 2013):

$$u_t + u^{1/2}u_x + \delta u_{xxx} = 0, \quad (4.1.69)$$

where the weakness of the dispersion are measured by the small parameter δ , it is controlled to the trapped particle of electron and suffix denotes the partial derivatives. The transformation, $u(x, t) = v^2(x, t)$, reduces the Eq. (4.1.69) into the following nonlinear wave equation,

$$v v_t + v^2 v_x + \delta (3 v_x v_{xx} + v v_{xxx}) = 0. \quad (4.1.70)$$

In order to construct solitary wave solutions to the Schamel equation for acoustic waves by applying the MSE method, we have used the following wave variable

$$v(x, t) = U(\xi), \quad \xi = kx - \omega t. \quad (4.1.71)$$

The wave variable (4.1.71) reduces Eq. (4.1.70) into the following ODE:

$$(-\omega + kU)U U' + \delta k^3(3U'U'' + UU''') = 0, \quad (4.1.72)$$

where the primes denote the derivatives with respect to ξ . Integrating Eq. (4.1.72) with respect to ξ , we then get a new ODE in the following form:

$$-\omega \frac{U^2}{2} + k \frac{U^3}{3} + \delta k^3 \{(U')^2 + UU''\} + C = 0, \quad (4.1.73)$$

where C be the integrating constant.

Balancing the terms U^3 and UU'' appearing in Eq. (4.1.73), we get $N = 2$. Hence, the structure of the solution of Eq. (4.1.73) is similar to the Eq. (4.1.1).

Now, inserting the values of U , U' and U'' from Eqs. (4.1.1)-(4.1.3) into Eq. (4.1.73), and executing the similar algorithm discussed in Sub-section 4.1(a) yields a set of simultaneous algebraic and differential equations for a_0 , a_1 , a_2 , $\psi(\xi)$ and additional essential parameters, which are given below:

$$C - \frac{1}{6}a_0^2(-3\omega + 2ka_0) = 0. \quad (4.1.74)$$

$$a_0a_1((-\omega + ka_0)\psi' + k^3\delta\psi''') = 0. \quad (4.1.75)$$

$$a_0a_2((-\omega + ka_0)(\psi')^2 + 2k^3\delta(\psi'')^2 + 2k^3\delta\psi'\psi''') - 3k^3\delta a_0a_1\psi'\psi'' + a_1^2\left(\left(-\frac{\omega}{2} + ka_0\right)(\psi')^2 + k^3\delta(\psi'')^2 + k^3\delta\psi'\psi'''\right) = 0. \quad (4.1.76)$$

$$\begin{aligned} & \frac{1}{3}\psi' \left(a_1(ka_1^2(\psi')^2 - 15k^3\delta a_1\psi'\psi'' \right. \\ & \quad \left. + 3a_2(-\omega(\psi')^2 + 6k^3\delta(\psi'')^2 + 3k^3\delta\psi'\psi''') \right) \\ & \quad \left. + 6ka_0\psi'(a_1(k^2\delta + a_2)\psi' - 5k^2\delta a_2\psi'') \right) = 0. \quad (4.1.77) \end{aligned}$$

$$\begin{aligned}
&ka_1^2(3k^2\delta + a_2)(\psi')^4 - 21k^3\delta a_1 a_2(\psi')^3\psi'' \\
&\quad + \frac{1}{2}a_2(\psi')^2(2ka_0(6k^2\delta + a_2)(\psi')^2 \\
&\quad + a_2(-\omega(\psi')^2 + 12k^3\delta(\psi'')^2 + 4k^3\delta\psi'\psi''')) = 0. \tag{4.1.78}
\end{aligned}$$

$$ka_2(\psi')^4(a_1(12k^2\delta + a_2)\psi' - 18k^2\delta a_2\psi'') = 0. \tag{4.1.79}$$

$$\frac{1}{3}ka_2^2(30k^2\delta + a_2)(\psi')^6 = 0. \tag{4.1.80}$$

We have solved the Eqs. (4.1.74)-(4.1.80) to find out a_i ($i = 1, 2, 3, \dots$), $\psi(\xi)$ and other necessary parameters. From Eq. (4.1.80), we obtain

$$a_2 = -30k^2\delta, \text{ since } a_2 \neq 0,$$

And from Eq. (4.1.79), we obtain

$$\psi(\xi) = \frac{900k^4\delta^2 c_1}{a_1^2} e^{\frac{\xi a_1}{30k^2\delta}} + c_2, \tag{4.1.81}$$

where c_1 and c_2 denote integrating constants.

Then by a suitable exploitation, from Eqs. (4.1.74) to (4.1.78), we compute

$$a_0 = 0, \quad a_1 = \pm 15\sqrt{k}\sqrt{\delta}\sqrt{\omega}, \quad C = 0$$

and

$$a_0 = \frac{5\omega}{4k}, \quad a_1 = \pm 15i\sqrt{k}\sqrt{\delta}\sqrt{\omega}, \quad C = \frac{25\omega^3}{192k^2}.$$

Since we have two set of values of a_0 , a_1 and C . Therefore, there arise two cases:

Case 1: When $a_0 = 0$, $a_1 = \pm 15\sqrt{k}\sqrt{\delta}\sqrt{\omega}$, $C = 0$, then from Eq. (4.1.81), we get

$$\psi(\xi) = \frac{4k^3\delta c_1}{\omega} e^{\pm \frac{\xi\sqrt{\omega}}{2k^{3/2}\sqrt{\delta}}} + c_2$$

where c_1 and c_2 are integrating constants.

Putting the obtained values of a_0 , a_1 , a_2 and $\psi(\xi)$ into Eq. (4.1.1), we explore the following solution to the Eq. (4.1.73):

$$U(\xi) = \frac{30 k^2 \delta \omega^2 c_1 c_2 e^{\pm \frac{\xi \sqrt{\omega}}{2k^{3/2}\sqrt{\delta}}}}{\left(4 k^3 \delta c_1 e^{\pm \frac{\xi \sqrt{\omega}}{2k^{3/2}\sqrt{\delta}}} + \omega c_2\right)^2}. \quad (4.1.82)$$

Since, we have used the transformation $u(x, t) = v^2(x, t)$ and $v(x, t) = U(\xi)$, so by using inverse transformation, we derive the following solitary wave solution to the modified Schamel equation for acoustic waves in plasma physics (4.1.69):

$$u(x, t) = \frac{900 k^4 \delta^2 \omega^4 c_1^2 c_2^2 e^{\pm \frac{\sqrt{\omega}(kx-t\omega)}{k^{3/2}\sqrt{\delta}}}}{\left(4 k^3 \delta c_1 e^{\pm \frac{\sqrt{\omega}(kx-t\omega)}{2k^{3/2}\sqrt{\delta}}} + \omega c_2\right)^4}. \quad (4.1.83)$$

Simplifying the solution (4.1.83), we obtain the subsequent solution to the modified Schamel equation:

$$\begin{aligned} u(x, t) = & (900k^4\delta^2\omega^4c_1^2c_2^2) \\ & / \left[4k^3\delta c_1 \left\{ \cosh\left(\frac{\sqrt{\omega}(kx-t\omega)}{4k^{\frac{3}{2}}\sqrt{\delta}}\right) \pm \sinh\left(\frac{\sqrt{\omega}(kx-t\omega)}{4k^{\frac{3}{2}}\sqrt{\delta}}\right) \right\} \right. \\ & \left. + \omega c_2 \left\{ \cosh\left(\frac{\sqrt{\omega}(kx-t\omega)}{4k^{\frac{3}{2}}\sqrt{\delta}}\right) \mp \sinh\left(\frac{\sqrt{\omega}(kx-t\omega)}{4k^{\frac{3}{2}}\sqrt{\delta}}\right) \right\} \right]^4. \quad (4.1.84) \end{aligned}$$

Since c_1 and c_2 are free parameters, one may arbitrarily take their values. Thus, if we take $c_1 = \omega$ and $c_2 = 4k^3\delta$, then from Eq. (4.1.84), we derive the following bell shape solitons solution to the modified Schamel equation:

$$u_{1,25}(x, t) = \frac{225\omega^2}{64k^2} \operatorname{sech}^4\left(\frac{\sqrt{\omega}(kx-t\omega)}{4k^{\frac{3}{2}}\sqrt{\delta}}\right). \quad (4.1.85)$$

Moreover, if we take $c_1 = \omega$ and $c_2 = -4k^3\delta$, then from exact solution (4.1.84), we obtain the singular bell shape solitary wave solution to the modified Schamel equation as follows:

$$u_{1,26}(x, t) = \frac{225\omega^2}{64k^2} \operatorname{csch}^4\left(\frac{\sqrt{\omega}(kx-t\omega)}{4k^{\frac{3}{2}}\sqrt{\delta}}\right). \quad (4.1.86)$$

Again, if we take $c_1 = \omega$ and $c_2 = \pm i 4k^3\delta$, then from solution (4.1.84), we derive the following solitary wave solution to the modified Schamel equation:

$$u_{1,27}(x, t) = \frac{225\omega^2}{64k^2} \csc^4 \left(\frac{\pi}{4} - \frac{\sqrt{\omega}(kx - t\omega)}{4k^{\frac{3}{2}}\sqrt{-\delta}} \right). \quad (4.1.87)$$

Once again, if we take $c_1 = \omega$ and $c_2 = \mp i 4k^3\delta$, then from solution (4.1.84), we derive the subsequent solitary wave solution to the modified Schamel equation:

$$u_{1,28}(x, t) = \frac{225\omega^2}{64k^2} \csc^4 \left[\frac{\pi}{4} + \frac{\sqrt{\omega}(kx - t\omega)}{4k^{\frac{3}{2}}\sqrt{-\delta}} \right]. \quad (4.1.88)$$

Case 2: When $a_0 = \frac{5\omega}{4k}$, $a_1 = \pm 15i\sqrt{k}\sqrt{\delta}\sqrt{\omega}$, $C = \frac{25\omega^3}{192k^2}$, then from Eq. (4.1.81), we get

$$\psi(\xi) = -\frac{4k^3\delta c_1}{\omega} e^{\pm \frac{i\xi\sqrt{\omega}}{2k^{3/2}\sqrt{\delta}}} + c_2$$

where c_1 and c_2 are constants of integration.

By means of the values of a_0 , a_1 , a_2 and $\psi(\xi)$, from Eq. (4.1.1), we obtain the following solution to the Eq. (4.1.73):

$$U(\xi) = \frac{5\omega}{4k} + \frac{30k^2\delta\omega^2 c_1 c_2 e^{\pm \frac{i\xi\sqrt{\omega}}{2k^{3/2}\sqrt{\delta}}}}{\left(-4k^3\delta c_1 e^{\pm \frac{i\xi\sqrt{\omega}}{2k^{3/2}\sqrt{\delta}}} + \omega c_2 \right)^2}. \quad (4.1.89)$$

By means of inverse transformation, we derive the following solitary wave solution to the modified Schamel equation:

$$u(x, t) = \left\{ \frac{5\omega}{4k} + \frac{30k^2\delta\omega^2 c_1 c_2 e^{\pm \frac{i(kx-t\omega)\sqrt{\omega}}{2k^{3/2}\sqrt{\delta}}}}{\left(-4k^3\delta c_1 e^{\pm \frac{i(kx-t\omega)\sqrt{\omega}}{2k^{3/2}\sqrt{\delta}}} + \omega c_2 \right)^2} \right\}^2. \quad (4.1.90)$$

Simplifying the solution (4.1.90), we determine the subsequent solution:

$$\begin{aligned}
u(x, t) = & \left(25\omega^2 \left[16k^6\delta^2c_1^2 \left\{ \cos\left(\frac{(kx-t\omega)\sqrt{\omega}}{2k^{\frac{3}{2}}\sqrt{\delta}}\right) \pm i\sin\left(\frac{(kx-t\omega)\sqrt{\omega}}{2k^{\frac{3}{2}}\sqrt{\delta}}\right) \right\} \right. \right. \\
& + 16k^3\delta\omega c_1c_2 \\
& \left. \left. + \omega^2c_2^2 \left\{ \cos\left(\frac{(kx-t\omega)\sqrt{\omega}}{2k^{\frac{3}{2}}\sqrt{\delta}}\right) \mp i\sin\left(\frac{(kx-t\omega)\sqrt{\omega}}{2k^{\frac{3}{2}}\sqrt{\delta}}\right) \right\} \right]^2 \right) \\
& / \left(16k^2 \left[-4k^3\delta c_1 \left\{ \cos\left(\frac{(kx-t\omega)\sqrt{\omega}}{4k^{\frac{3}{2}}\sqrt{\delta}}\right) \pm i\sin\left(\frac{(kx-t\omega)\sqrt{\omega}}{4k^{\frac{3}{2}}\sqrt{\delta}}\right) \right\} \right. \right. \\
& \left. \left. + \omega c_2 \left\{ \cos\left(\frac{(kx-t\omega)\sqrt{\omega}}{4k^{\frac{3}{2}}\sqrt{\delta}}\right) \mp i\sin\left(\frac{(kx-t\omega)\sqrt{\omega}}{4k^{\frac{3}{2}}\sqrt{\delta}}\right) \right\} \right]^4 \right). \quad (4.1.91)
\end{aligned}$$

Since c_1 and c_2 are arbitrary constants, one may intuitively choose their values. Thus, if we choose $c_1 = \omega$ and $c_2 = 4k^3\delta$, then from Eq. (4.1.91), we obtain the following bell shape solution to the modified Schamel equation:

$$u_{1,29}(x, t) = \frac{25\omega^2}{64k^2} \left\{ -2 - 3 \operatorname{csch}^2 \left(\frac{\sqrt{\omega}(kx-t\omega)}{4k^{\frac{3}{2}}\sqrt{-\delta}} \right) \right\}^2. \quad (4.1.92)$$

Furthermore, if we choose $c_1 = \omega$ and $c_2 = -4k^3\delta$, then from solution (4.1.91), we attain the singular bell shape solitary wave solution to the modified Schamel equation as follows:

$$u_{1,30}(x, t) = \frac{25\omega^2}{64k^2} \left\{ 2 - 3 \operatorname{sech}^2 \left(\frac{\sqrt{\omega}(kx-t\omega)}{4k^{\frac{3}{2}}\sqrt{-\delta}} \right) \right\}^2. \quad (4.1.93)$$

On the other hand, if we choose $c_1 = \omega$ and $c_2 = \pm i 4k^3\delta$, then from solution (4.1.91), we achieve the following solitary wave solution to the modified Schamel equation:

$$u_{1,31}(x, t) = \frac{25\omega^2}{64k^2} \left\{ -2 + 3 \operatorname{csc}^2 \left(\frac{\pi}{4} - \frac{\sqrt{\omega}(kx-t\omega)}{4k^{\frac{3}{2}}\sqrt{\delta}} \right) \right\}^2. \quad (4.1.94)$$

Again, if we choose $c_1 = \omega$ and $c_2 = \mp i 4k^3\delta$, then from solution (4.1.91), we get the following solitary wave solution to the modified Schamel equation:

$$u_{1,32}(x, t) = \frac{25\omega^2}{64k^2} \left\{ 2 - 3 \operatorname{csc}^2 \left(\frac{\pi}{4} + \frac{\sqrt{\omega}(kx - t\omega)}{4k^{\frac{3}{2}}\sqrt{\delta}} \right) \right\}^2. \quad (4.1.95)$$

Since, c_1 and c_2 are arbitrary constants for further choices of c_1 and c_2 , we might obtain some potential and more general solitary wave solutions to the modified Schamel equation for acoustic waves in plasma physics (4.1.69) by using the MSE method with the aid symbolic computation software, like Mathematica.

Remark 4.1(d): The solutions (4.1.85)-(4.1.88) and (4.1.92)-(4.1.95) have been validated by putting them back into the initial equation (4.1.69) and found perfect.

4.1(e): The Modified Kadomtsev-Petviashvili (KP) Equation for Acoustic Waves in Plasma Physics

In this sub-section, we have ensured the use of the MSE method to extract exact solitary wave solutions to the modified Kadomtsev-Petviashvili (KP) equation for acoustic waves, which is very important in plasma physics. The nonlinear modified KP equation is a very attractive model for the study in ion acoustic waves, also this equation holds a square derivation in multi-type plasma fabricated of non-isothermal electrons in plasma physics. Let us consider the modified KP equation for acoustic waves in plasma physics as follows (Taha et al., 2013):

$$(u_t + \alpha u^{1/2}u_x + \beta u_{xx})_x + \delta u_{yy} = 0, \quad (4.1.96)$$

where the weakness of the scattering can be measured by the small parameters α, β and δ , it is controlled to the trapped particle of electron and suffix denotes the partial derivatives. Consider the transformation $u(x, y, t) = v^2(x, y, t)$, then the Eq. (4.1.96) can be written as

$$(v v_t + \alpha v^2 v_x + 3 \beta v_x v_{xx} + \beta v v_{xxx})_x + \delta \left\{ (v_y)^2 + v v_{yy} \right\} = 0. \quad (4.1.97)$$

In order to construct solitary wave solutions to the modified KP equation (4.1.96) by using the MSE method, we organize the traveling wave variable as follows:

$$v(x, y, t) = U(\xi), \quad \xi = x + k y - \omega t. \quad (4.1.98)$$

We operate the traveling wave transformation (4.1.98), then Eq. (4.1.97) switch to the following ODE:

$$\{-\omega U U' + \alpha U^2 U' + \beta (3 U' U'' + U U''')\}' + \delta k^2 \{(U')^2 + U U''\} = 0, \quad (4.1.99)$$

where primes indicate the derivatives with respect to ξ . Integrating Eq. (4.1.99) with respect to ξ and setting the integrating constant to zero, we achieve the subsequent ODE:

$$(\delta k^2 - \omega) U U' + \alpha U^2 U' + \beta (3 U' U'' + U U''') = 0. \quad (4.1.100)$$

Now, balancing the terms $U^2 U'$ and $U U'''$ appearing in Eq. (4.1.100), we derive $N = 2$. So, the outline of solution of Eq. (4.1.100) is analogous to the solution Eq. (4.1.1).

Hence, we have used the values of U , U' , U'' and U''' from the Eq. (4.1.1)-(4.1.4) into Eq. (4.1.100) and then the left-hand side of Eq. (4.1.100) is converted into a polynomial of $\left(\frac{1}{\psi(\xi)}\right)$. We assemble all the coefficients of the same order of the resultant polynomial $\left(\frac{1}{\psi(\xi)}\right)^i$, ($i = 0, 1, 2, 3, \dots$) to zero, which yield a system of algebraic and differential equations for a_i ($i = 0, 1, 2, \dots, N$), $\psi(\xi)$ and other needful constraints. Here it is noteworthy to observe that for the KP equation, we did not get any equation concerning the value $i = 0$. Thus, we obtain the other subsequent algebraic and differential equations:

$$a_0 a_1 \{(k^2 \delta - \omega + \alpha a_0) \psi'' + \beta \psi^{(iv)}\} = 0. \quad (4.1.101)$$

$$\begin{aligned} & \alpha a_0^2 \psi' (-a_1 \psi' + 2a_2 \psi'') + a_1^2 [3\beta \psi'' \psi''' + \psi' \{(k^2 \delta - \omega) \psi'' + \beta \psi^{(iv)}\}] \\ & + a_0 [2\alpha a_1^2 \psi' \psi'' - a_1 \{(k^2 \delta - \omega) (\psi')^2 + 3\beta (\psi'')^2 + 4\beta \psi' \psi'''\}] \\ & + 2a_2 \{3\beta \psi'' \psi''' + \psi' \{(k^2 \delta - \omega) \psi'' + \beta \psi^{(iv)}\}\} = 0. \quad (4.1.102) \end{aligned}$$

$$\begin{aligned}
& 3a_1 \left[a_2 \left\{ 2\beta(\psi'')^3 + 6\beta\psi'\psi''\psi''' + (\psi')^2 \left((k^2\delta - \omega)\psi'' + \beta\psi^{(iv)} \right) \right\} \right. \\
& \quad \left. + 2a_0(2\beta + \alpha a_2)(\psi')^2\psi'' \right] - 2a_0a_2(k^2\delta - \omega + \alpha a_0)(\psi')^3 \\
& \quad - 2a_0a_2\psi' \{ 12\beta(\psi'')^2 + 7\beta\psi'\psi''' \} - a_1^2(k^2\delta - \omega + 2\alpha a_0)(\psi')^3 \\
& \quad - a_1^2\psi' \{ 12\beta(\psi'')^2 + 7\beta\psi'\psi''' \} + \alpha a_1^3(\psi')^2\psi'' = 0. \quad (4.1.103)
\end{aligned}$$

$$\begin{aligned}
& \psi' \left[-\alpha a_1^3(\psi')^3 + a_1^2(27\beta + 4\alpha a_2)(\psi')^2\psi'' - 6a_0a_1(\beta + \alpha a_2)(\psi')^3 \right. \\
& \quad \left. + 2a_2^2 \left\{ 6\beta(\psi'')^3 + 9\beta\psi'\psi''\psi''' + (\psi')^2 \left((k^2\delta - \omega)\psi'' + \beta\psi^{(iv)} \right) \right\} \right. \\
& \quad \left. - 3a_1a_2\psi' \{ (k^2\delta - \omega)(\psi')^2 + 27\beta(\psi'')^2 + 10\beta\psi'\psi''' \} \right. \\
& \quad \left. + 2a_0a_2(27\beta + 2\alpha a_2)(\psi')^2\psi'' \right] = 0. \quad (4.1.104)
\end{aligned}$$

$$\begin{aligned}
& -(\psi')^3 \left[4a_1^2(3\beta + \alpha a_2)(\psi')^2 - a_1a_2(144\beta + 5\alpha a_2)\psi'\psi'' \right. \\
& \quad \left. + 2a_2 \{ a_2((k^2\delta - \omega)(\psi')^2 + 48\beta(\psi'')^2 + 13\beta\psi'\psi''') \right. \\
& \quad \left. + 2a_0(6\beta + \alpha a_2)(\psi')^2 \} \right] = 0. \quad (4.1.105)
\end{aligned}$$

$$a_2(\psi')^5(-5a_1(12\beta + \alpha a_2)\psi' + 2a_2(75\beta + \alpha a_2)\psi'') = 0. \quad (4.1.106)$$

$$-2a_2^2(30\beta + \alpha a_2)(\psi')^7 = 0. \quad (4.1.107)$$

Now, we have solved Eqs. (4.1.101)-(4.1.107) in order to find out the values of a_0, a_1, a_2 and $\psi(\xi)$. From Eq. (4.1.106), we derive

$$\psi(\xi) = \frac{30\beta c_1}{\alpha a_1} e^{\frac{\alpha \xi a_1}{30\beta}} + c_2, \quad (4.1.108)$$

where c_1 and c_2 are constants of integration.

From Eq. (4.1.107), we derive

$$a_2 = -\frac{30\beta}{\alpha}, \quad \text{since } a_2 \neq 0.$$

Therefore, using the values of a_2 and $\psi(\xi)$ into Eqs. (4.1.101) to (4.1.105) yields a set of algebraic equation for a_0 and a_1 and solving the algebraic equations, we obtain

$$a_0 = 0, \quad a_1 = \pm \frac{15\sqrt{-k^2\beta\delta + \beta\omega}}{\alpha}$$

and

$$a_0 = -\frac{5(k^2\delta - \omega)}{4\alpha}, \quad a_1 = \pm \frac{15\sqrt{k^2\beta\delta - \beta\omega}}{\alpha}.$$

Hence the following two cases arise:

Case 1: When $a_0 = 0$ and $a_1 = \pm \frac{15\sqrt{-k^2\beta\delta + \beta\omega}}{\alpha}$, inserting the value of a_1 into Eq.

(4.1.108), we obtain

$$\psi(\xi) = \pm \frac{2\beta c_1}{\sqrt{-k^2\beta\delta + \beta\omega}} e^{\pm \frac{\xi\sqrt{-k^2\beta\delta + \beta\omega}}{2\beta}} + c_2$$

where c_1 and c_2 are arbitrary constants.

Now, inserting the values of a_0 , a_1 , a_2 and $\psi(\xi)$, from Eq. (4.1.1), we obtain the following solution to the Eq. (4.1.100):

$$U(\xi) = \mp \frac{15\beta(k^2\delta - \omega)\sqrt{\beta(-k^2\delta + \omega)}c_1c_2 e^{\pm \frac{\xi\sqrt{\beta(-k^2\delta + \omega)}}{2\beta}}}{\alpha \left\{ \pm 2\beta c_1 e^{\pm \frac{\xi\sqrt{\beta(-k^2\delta + \omega)}}{2\beta}} + \sqrt{\beta(-k^2\delta + \omega)}c_2 \right\}^2}. \quad (4.1.109)$$

Now, using the inverse transformation, we obtain the solution to the modified KP equation in the following form:

$$u(x, y, t) = \frac{225\beta^3(k^2\delta - \omega)^2(-k^2\delta + \omega)c_1^2c_2^2 e^{\pm \frac{\sqrt{\beta(-k^2\delta + \omega)}(x+ky-t\omega)}{\beta}}}{\alpha^2 \left\{ \pm 2\beta c_1 e^{\pm \frac{\sqrt{\beta(-k^2\delta + \omega)}(x+ky-t\omega)}{2\beta}} + \sqrt{\beta(-k^2\delta + \omega)}c_2 \right\}^4}. \quad (4.1.110)$$

Simplifying the solution (4.1.110), we obtain the subsequent solution to the modified KP equation:

$$\begin{aligned}
u(x, y, t) = & -(225\beta^3(k^2\delta - \omega)^3 c_1^2 c_2^2) \\
& / \left(\alpha^2 \left[2\beta \{ \pm \cosh(\sigma(x + ky - t\omega)) + \sinh(\sigma(x + ky - t\omega)) \} c_1 \right. \right. \\
& + \sqrt{\beta(-k^2\delta + \omega)} \{ \cosh(\sigma(x + ky - t\omega)) \\
& \left. \left. \mp \sinh(\sigma(x + ky - t\omega)) \} c_2 \right]^4 \right), \tag{4.1.111}
\end{aligned}$$

where $\sigma = \frac{\sqrt{\beta(-k^2\delta + \omega)}}{4\beta}$.

Forasmuch as c_1 and c_2 are arbitrary constants, one may randomly select their values. If we take $c_1 = \pm\sqrt{\beta(-k^2\delta + \omega)}$ and $c_2 = 2\beta$, then from Eq. (4.1.111), we find out the following bell shape soliton solution to the modified KP equation:

$$u_{1,33}(x, y, t) = \frac{225(-k^2\delta + \omega)^2 \operatorname{sech}^4\left(\frac{\sqrt{\beta(-k^2\delta + \omega)}(x + ky - t\omega)}{4\beta}\right)}{64\alpha^2}. \tag{4.1.112}$$

Furthermore, if we take $c_1 = \mp\sqrt{\beta(-k^2\delta + \omega)}$ and $c_2 = 2\beta$, then from solution (4.1.111), we find out the singular bell shape solitary wave solution to the modified KP equation:

$$u_{1,34}(x, y, t) = \frac{225(-k^2\delta + \omega)^2 \operatorname{csch}^4\left(\frac{\sqrt{\beta(-k^2\delta + \omega)}(x + ky - t\omega)}{4\beta}\right)}{64\alpha^2}. \tag{4.1.113}$$

Alternatively, if we take $c_1 = i\sqrt{\beta(-k^2\delta + \omega)}$ and $c_2 = 2\beta$, from solution (4.1.111), we find out the subsequent solitary wave solution to the modified KP equation:

$$\begin{aligned}
u_{1,35}(x, y, t) = & -\{225(-k^2\delta + \omega)^2\} \\
& / \left[8\alpha^2 \left\{ -3 + \cos\left(\frac{\sqrt{k^2\delta - \omega}(x + ky - t\omega)}{\sqrt{\beta}}\right) \right. \right. \\
& \left. \left. + 4\sin\left(\frac{\sqrt{k^2\delta - \omega}(x + ky - t\omega)}{2\sqrt{\beta}}\right) \right\} \right]. \tag{4.1.114}
\end{aligned}$$

Once again, if we take $c_1 = -i\sqrt{\beta(-k^2\delta + \omega)}$ and $c_2 = 2\beta$, from solution (4.1.111), we find out the following solitary wave solution to the modified KP equation:

$$u_{1,36}(x, y, t) = -\{225(k^4\delta^2 - 2k^2\delta\omega + \omega^2)\} / \left[8\alpha^2 \left\{ -3 + \cos\left(\frac{\sqrt{\beta(k^2\delta - \omega)}(x + ky - t\omega)}{\beta}\right) - 4\sin\left(\frac{\sqrt{\beta(k^2\delta - \omega)}(x + ky - t\omega)}{2\beta}\right) \right\} \right]. \quad (4.1.115)$$

Case 2: When $a_0 = -\frac{5(k^2\delta - \omega)}{4\alpha}$ and $a_1 = \pm \frac{15\sqrt{k^2\beta\delta - \beta\omega}}{\alpha}$, inserting the value of a_1 into Eq. (4.1.108), we obtain

$$\psi(\xi) = \pm \frac{2\beta c_1}{\sqrt{k^2\beta\delta - \beta\omega}} e^{\pm \frac{\xi\sqrt{k^2\beta\delta - \beta\omega}}{2\beta}} + c_2$$

where c_1 and c_2 are arbitrary constants.

Now, inserting the values of a_0 , a_1 , a_2 and $\psi(\xi)$, from Eq. (4.1.1), we obtain the following solution to the Eq. (4.1.100):

$$U(\xi) = - \left[5\beta(k^2\delta - \omega) \left\{ 4\beta c_1^2 e^{\pm \frac{\xi\sqrt{\beta(k^2\delta - \omega)}}{\beta}} \mp 8\sqrt{\beta(k^2\delta - \omega)} c_1 c_2 e^{\pm \frac{\xi\sqrt{\beta(k^2\delta - \omega)}}{2\beta}} + (k^2\delta - \omega) c_2^2 \right\} \right] / \left[4\alpha \left\{ \pm 2\beta c_1 e^{\pm \frac{\xi\sqrt{\beta(k^2\delta - \omega)}}{2\beta}} + \sqrt{\beta(k^2\delta - \omega)} c_2 \right\}^2 \right]. \quad (4.1.116)$$

Now, under application of inverse transformation, we obtain the solution to the modified KP equation in the following form:

$$\begin{aligned}
u(x, y, t) = & \left[25\beta^2(k^2\delta - \omega)^2 \left\{ 4\beta c_1^2 e^{\pm \frac{(x+ky-t\omega)\sqrt{\beta(k^2\delta-\omega)}}{\beta}} \mp 8\sqrt{\beta(k^2\delta - \omega)} c_1 c_2 \right. \right. \\
& \left. \left. \times e^{\pm \frac{(x+ky-t\omega)\sqrt{\beta(k^2\delta-\omega)}}{2\beta}} + (k^2\delta - \omega)c_2^2 \right\}^2 \right] \\
& / \left[16\alpha^2 \left\{ c_2\sqrt{\beta(k^2\delta - \omega)} \pm 2\beta c_1 e^{\pm \frac{(x+ky-t\omega)\sqrt{\beta(k^2\delta-\omega)}}{2\beta}} \right\}^4 \right]. \quad (4.1.117)
\end{aligned}$$

Upon simplification, the solution (4.1.117) transformed to the following hyperbolic solution to the modified KP equation:

$$\begin{aligned}
u(x, y, t) = & \left(25\beta^2(-k^2\delta + \omega)^2 \left[-8\sqrt{\beta(k^2\delta - \omega)} c_1 c_2 + 4\beta c_1^2 \right. \right. \\
& \times \{ \cosh(2\theta(x + ky - t\omega)) + \sinh(2\theta(x + ky - t\omega)) \} \\
& + (k^2\delta - \omega)c_2^2 \\
& \times \{ \cosh(2\theta(x + ky - t\omega)) - \sinh(2\theta(x + ky - t\omega)) \} \left. \right]^2 \\
& / \left(16\alpha^2 \left[2\beta c_1 \{ \cosh(\theta(x + ky - t\omega)) + \sinh(\theta(x + ky - t\omega)) \} \right. \right. \\
& + c_2\sqrt{\beta(k^2\delta - \omega)} \{ \cosh(\theta(x + ky - t\omega)) \\
& \left. \left. - \sinh(\theta(x + ky - t\omega)) \} \right] \right)^4, \quad (4.1.118)
\end{aligned}$$

where $\theta = \frac{\sqrt{(k^2\delta-\omega)}}{4\sqrt{\beta}}$.

Now, we choose $c_1 = \pm\sqrt{\beta(k^2\delta - \omega)}$ and $c_2 = 2\beta$, because c_1 and c_2 are arbitrary constants. Then from Eq. (4.1.118), we derive the following solution to the modified KP equation:

$$u_{1,37}(x, y, t) = \frac{25(-k^2\delta + \omega)^2}{64\alpha^2} \operatorname{sech}^4 \left(\frac{\sqrt{\beta(k^2\delta - \omega)}(x + ky - t\omega)}{4\beta} \right) \times \left\{ -2 + \cosh \left(\frac{\sqrt{\beta(k^2\delta - \omega)}(x + ky - t\omega)}{2\beta} \right) \right\}^2. \quad (4.1.119)$$

In addition, if we choose $c_1 = \mp\sqrt{\beta(k^2\delta - \omega)}$ and $c_2 = 2\beta$, then from solution (4.1.118), we obtain the subsequent solution to the modified KP:

$$u_{1,38}(x, y, t) = \frac{1}{64\alpha^2} 25(-k^2\delta + \omega)^2 \operatorname{csch}^4 \left(\frac{\sqrt{\beta(k^2\delta - \omega)}(x + ky - t\omega)}{4\beta} \right) \times \left\{ 2 + \cosh \left(\frac{\sqrt{\beta(k^2\delta - \omega)}(x + ky - t\omega)}{2\beta} \right) \right\}^2. \quad (4.1.120)$$

On the other hand, if we pick $c_1 = i\sqrt{\beta(k^2\delta - \omega)}$ and $c_2 = 2\beta$, then from solution (4.1.118), we explore the following solitary wave solution to the modified KP equation:

$$u_{1,39}(x, y, t) = \frac{1}{64\alpha^2} 25(k^2\delta - \omega)^2 \times \left(2 + \sin \left[\frac{\sqrt{-\beta(k^2\delta - \omega)}(x + ky - t\omega)}{2\beta} \right] \right)^2 \times \operatorname{csc}^4 \left(\frac{\pi}{4} - \frac{\sqrt{-\beta(k^2\delta - \omega)}(x + ky - t\omega)}{4\beta} \right). \quad (4.1.121)$$

However, if we put $c_1 = -i\sqrt{\beta(k^2\delta - \omega)}$ and $c_2 = 2\beta$, then from solution (4.1.118), we derive the following solitary wave solution to the modified KP equation:

$$u_{1,40}(x, y, t) = \frac{1}{64\alpha^2} 25(k^2\delta - \omega)^2 \operatorname{csc}^4 \left(\frac{\pi}{4} + \frac{\sqrt{-k^2\delta + \omega}(x + ky - t\omega)}{4\sqrt{\beta}} \right) \times \left\{ -2 + \sin \left(\frac{\sqrt{-k^2\delta + \omega}(x + ky - t\omega)}{2\sqrt{\beta}} \right) \right\}^2. \quad (4.1.122)$$

In view of the fact that, c_1 and c_2 are arbitrary constants for any choices of c_1 and c_2 , we might obtain some admirable new and more general solitary wave solutions to the

modified KP equation for acoustic waves in plasma physics (4.1.96) via the MSE method with sincerity of typical computation software, i.e. Mathematica.

Remark 4.1(e): The solutions (4.1.112)-(4.1.115) and (4.1.119)-(4.1.122) have been verified by putting them back into the original equation (4.1.96) and found accurate.

4.1(f): The Strain Wave Equation in Microstructured Solids

In this sub-section, we have put through the MSE method to extract solitary wave solutions to the strain wave equation in microstructured solids, which is a very important equation in the field of engineering. We have sought some new solitary wave solutions to this equation by using the MSE method. Let us consider strain wave equation in microstructured solids in the following form:

$$u_{tt} - u_{xx} - \varepsilon \alpha_1 (u^2)_{xx} - \gamma \alpha_2 u_{xxt} + \delta \alpha_3 u_{xxxx} - (\delta \alpha_4 - \gamma^2 \alpha_7) u_{xxtt} + \gamma \delta (\alpha_5 u_{xxxxt} + \alpha_6 u_{xxtt}) = 0. \quad (4.1.123)$$

4.1(f)-I: The Non-dissipative Case

The system is non-dissipative, if $\gamma = 0$ and governed by the double dispersive equation (Pastrone, 2009; Pastrone et al., 2004; Porubov and Pastrone, 2004; Samsonov, 2001),

$$u_{tt} - u_{xx} - \varepsilon \alpha_1 (u^2)_{xx} + \delta \alpha_3 u_{xxxx} - \delta \alpha_4 u_{xxtt} = 0. \quad (4.1.124)$$

The balance between dispersion and nonlinearities happen when $\delta = O(\varepsilon)$. Therefore, (4.1.124) becomes

$$u_{tt} - u_{xx} - \varepsilon \{ \alpha_1 (u^2)_{xx} - \alpha_3 u_{xxxx} + \alpha_4 u_{xxtt} \} = 0. \quad (4.1.125)$$

In order to construct exact traveling wave solutions to the strain wave equation in microstructured solids for non-dissipative case by concerning the MSE method, we have considered the traveling wave variable specified in (4.1.7).

The traveling wave transformation (4.1.7), reduces Eq. (4.1.125) to the following equation:

$$(\omega^2 - 1) U'' - \varepsilon\{\alpha_1 (U^2)'' - (\alpha_3 - \omega^2\alpha_4) U^{(iv)}\} = 0, \quad (4.1.126)$$

where prime shows the derivative with respect to ξ . By integrating Eq. (4.1.126) twice with respect to ξ , we obtain the subsequent ODE:

$$(\omega^2 - 1) U - \varepsilon\{\alpha_1 U^2 - (\alpha_3 - \omega^2\alpha_4) U''\} = 0, \quad (4.1.127)$$

where the integration constants are set to zero, as we are seeking solitary wave solutions.

Now, balancing the nonlinear term of the highest order U^2 and the highest order derivative U'' of the Eq. (4.1.127), we obtain $N = 2$. So, the outline of the solution of Eq. (4.1.127) is similar to the Eq. (4.1.1).

Now, we have used the values of U and U'' from the Eq. (4.1.1) and Eq. (4.1.3) into Eq. (4.1.127), and executing the parallel course of algorithm discussed in Sub-section 4.1(a) yields a set of simultaneous algebraic and differential equations for $a_0, a_1, a_2, \psi(\xi)$ and additional essential parameters, which are given in the subsequent form:

$$a_0(-1 + \omega^2 - \varepsilon a_0\alpha_1) = 0. \quad (4.1.128)$$

$$a_1\{(-1 + \omega^2 - 2\varepsilon a_0\alpha_1)\psi' + \varepsilon(\alpha_3 - \omega^2\alpha_4)\psi'''\} = 0. \quad (4.1.129)$$

$$\begin{aligned} & -\varepsilon a_1\psi'\{a_1\alpha_1\psi' + 3(\alpha_3 - \omega^2\alpha_4)\psi''\} \\ & \quad + a_2\{(-1 + \omega^2 - 2\varepsilon a_0\alpha_1)(\psi')^2 + 2\varepsilon(\alpha_3 - \omega^2\alpha_4)(\psi'')^2 \\ & \quad + 2\varepsilon(\alpha_3 - \omega^2\alpha_4)\psi'\psi'''\} = 0. \end{aligned} \quad (4.1.130)$$

$$-2\varepsilon(\psi')^2\{a_1(a_2\alpha_1 - \alpha_3 + \omega^2\alpha_4)\psi' + 5a_2(\alpha_3 - \omega^2\alpha_4)\psi''\} = 0. \quad (4.1.131)$$

$$-\varepsilon a_2(a_2\alpha_1 - 6\alpha_3 + 6\omega^2\alpha_4)(\psi')^4 = 0. \quad (4.1.132)$$

From Eqs. (4.1.128) and (4.1.132), we compute

$$a_0 = 0, \quad \frac{-1 + \omega^2}{\varepsilon\alpha_1}$$

and

$$a_2 = \frac{6(\alpha_3 - \omega^2 \alpha_4)}{\alpha_1}, \quad \text{since } a_2 \neq 0.$$

Therefore, for the values of a_0 , the following two cases arise:

Case 1: When $a_0 = 0$, we have to adopt the same technique as we have adopted in section 4.1(a). Therefore, from Eqs. (4.1.129) to (4.1.131), we obtain

$$a_1 = \pm \frac{6i\sqrt{-1 + \omega^2} \sqrt{\alpha_3 - \omega^2 \alpha_4}}{\sqrt{\varepsilon} \alpha_1}$$

and

$$\psi(\xi) = c_2 + \frac{\varepsilon c_1 (-\alpha_3 + \omega^2 \alpha_4)}{-1 + \omega^2} e^{\mp \frac{i\xi \sqrt{-1 + \omega^2}}{\sqrt{\varepsilon} \sqrt{\alpha_3 - \omega^2 \alpha_4}}}$$

where c_1 and c_2 are integration constants.

Setting the values of a_0, a_1, a_2 and $\psi(\xi)$ in Eq. (4.1.1) and then we found the exponential solution of the ODE (4.1.127) as:

$$U(\xi) = \frac{6e^{\pm \frac{i\xi \sqrt{-1 + \omega^2}}{\sqrt{\varepsilon} \sqrt{\alpha_3 - \omega^2 \alpha_4}}} (-1 + \omega^2)^2 c_1 c_2 (-\alpha_3 + \omega^2 \alpha_4)}{\alpha_1 \left((-1 + \omega^2) c_2 e^{\pm \frac{i\xi \sqrt{-1 + \omega^2}}{\sqrt{\varepsilon} \sqrt{\alpha_3 - \omega^2 \alpha_4}}} + \varepsilon c_1 (-\alpha_3 + \omega^2 \alpha_4) \right)^2}. \quad (4.1.133)$$

Upon simplification, the exponential solution (4.1.133) transformed the subsequent hyperbolic solution to the strain wave equation in microstructured solids for non-dissipative case (4.1.124):

$$\begin{aligned}
u(x, t) = & \{6(-1 + \omega^2)^2 c_1 c_2 (-\alpha_3 + \omega^2 \alpha_4)\} \\
& / \left[\alpha_1 \left\{ \pm i \sin \left(\frac{(x - t\omega)\sqrt{-1 + \omega^2}}{2\sqrt{\varepsilon}\sqrt{\alpha_3 - \omega^2 \alpha_4}} \right) \{(-1 + \omega^2)c_2 \right. \right. \\
& + \varepsilon c_1 (\alpha_3 - \omega^2 \alpha_4)\} + \cos \left(\frac{(x - t\omega)\sqrt{-1 + \omega^2}}{2\sqrt{\varepsilon}\sqrt{\alpha_3 - \omega^2 \alpha_4}} \right) \\
& \left. \left. \times \{(-1 + \omega^2)c_2 + \varepsilon c_1 (-\alpha_3 + \omega^2 \alpha_4)\} \right\}^2 \right], \tag{4.1.134}
\end{aligned}$$

Since c_1 and c_2 are arbitrary constants, we may openhandedly pick their values. Thus, if we declare $c_1 = (-1 + \omega^2)$ and $c_2 = \varepsilon(-\alpha_3 + \omega^2 \alpha_4)$, then from Eq. (4.1.134), we develop the following solution to the strain wave equation in microstructured solids for non-dissipative case (4.1.124):

$$u_{1,41}(x, t) = \frac{3(-1 + \omega^2)}{2\varepsilon\alpha_1} \operatorname{sech}^2 \left(\frac{(x - t\omega)\sqrt{-1 + \omega^2}}{2\sqrt{\varepsilon}\sqrt{-\alpha_3 + \omega^2 \alpha_4}} \right). \tag{4.1.135}$$

Once more, if we declare $c_1 = (-1 + \omega^2)$ and $c_2 = -\varepsilon(-\alpha_3 + \omega^2 \alpha_4)$, then from exact solution (4.1.134), we explore the singular bell shape solitary wave solution to the strain wave equation in microstructured solids for non-dissipative case:

$$u_{1,42}(x, t) = -\frac{3(-1 + \omega^2)}{2\varepsilon\alpha_1} \operatorname{csch}^2 \left(\frac{(x - t\omega)\sqrt{-1 + \omega^2}}{2\sqrt{\varepsilon}\sqrt{-\alpha_3 + \omega^2 \alpha_4}} \right). \tag{4.1.136}$$

Again, if we take $c_1 = (-1 + \omega^2)$ and $c_2 = \pm i \varepsilon(-\alpha_3 + \omega^2 \alpha_4)$, then from exact solution (4.1.134), we investigate the following solitary wave solution to the strain wave equation in microstructured solids for non-dissipative case:

$$u_{1,43}(x, t) = \frac{3(-1 + \omega^2)}{2\varepsilon\alpha_1} \sec^2 \left[\frac{1}{4} \left\{ \pi + \frac{2(x - t\omega)\sqrt{-1 + \omega^2}}{\sqrt{\varepsilon}\sqrt{\alpha_3 - \omega^2 \alpha_4}} \right\} \right]. \tag{4.1.137}$$

Yet again, if we put $c_1 = (-1 + \omega^2)$ and $c_2 = \mp i \varepsilon(-\alpha_3 + \omega^2 \alpha_4)$, then from solution (4.1.134), we evaluate the following solitary wave solution to the strain wave equation in microstructured solids for non-dissipative case:

$$u_{1,44}(x, t) = \frac{3(-1 + \omega^2)}{2\varepsilon\alpha_1} \sec^2 \left[\frac{1}{4} \left\{ \pi - \frac{2(x - t\omega)\sqrt{-1 + \omega^2}}{\sqrt{\varepsilon}\sqrt{\alpha_3 - \omega^2\alpha_4}} \right\} \right]. \quad (4.1.138)$$

Case 2: When $a_0 = \frac{-1+\omega^2}{\varepsilon\alpha_1}$, we have to adopt the same technique as we have adopted in section 4.1(a). Therefore, from Eqs. (4.1.129) to (4.1.131), we estimate

$$a_1 = \pm \frac{6\sqrt{-1 + \omega^2}\sqrt{\alpha_3 - \omega^2\alpha_4}}{\sqrt{\varepsilon}\alpha_1}$$

and

$$\psi(\xi) = c_2 + \frac{\varepsilon c_1(\alpha_3 - \omega^2\alpha_4)}{-1 + \omega^2} e^{\mp \frac{\xi\sqrt{-1+\omega^2}}{\sqrt{\varepsilon}\sqrt{\alpha_3-\omega^2\alpha_4}}}$$

where c_1 and c_2 denotes integrating constants.

Inserting the values of a_0, a_1, a_2 and $\psi(\xi)$ in Eq. (4.1.1) and then modifying the exponential solution, we obtain

$$U(\xi) = \frac{-1 + \omega^2}{\varepsilon\alpha_1} + \frac{6(-1 + \omega^2)^2 c_1 c_2 (-\alpha_3 + \omega^2 \alpha_4) e^{\pm \frac{\xi\sqrt{-1+\omega^2}}{\sqrt{\varepsilon}\sqrt{\alpha_3-\omega^2\alpha_4}}}}{\alpha_1 \left\{ (-1 + \omega^2) c_2 e^{\pm \frac{\xi\sqrt{-1+\omega^2}}{\sqrt{\varepsilon}\sqrt{\alpha_3-\omega^2\alpha_4}}} + \varepsilon c_1 (\alpha_3 - \omega^2 \alpha_4) \right\}^2}. \quad (4.1.139)$$

After simplification, the exponential solution (4.1.139) transferred to the hyperbolic solution to the strain wave equation in microstructured solids for non-dissipative case:

$$\begin{aligned}
u(x, t) = & (-1 + \omega^2)[4\varepsilon(-1 + \omega^2)c_1c_2(-\alpha_3 + \omega^2\alpha_4) + (-1 + \omega^2)^2c_2^2 \\
& \times \{\cosh(2\varphi(x - t\omega)) + \sinh(2\varphi(x - t\omega))\} \\
& + \varepsilon^2c_1^2(\alpha_3 - \omega^2\alpha_4)^2\{\cosh(2\varphi(x - t\omega)) - \sinh(2\varphi(x - t\omega))\}] \\
& / (\varepsilon\alpha_1[(-1 + \omega^2)c_2\{\cosh(\varphi(x - t\omega)) + \sinh(\varphi(x - t\omega))\}] \\
& + \varepsilon c_1(\alpha_3 - \omega^2\alpha_4) \\
& \times \{\cosh(\varphi(x - t\omega)) - \sinh(\varphi(x - t\omega))\}]^2), \tag{4.1.140}
\end{aligned}$$

where $\varphi = \frac{\sqrt{-1+\omega^2}}{2\sqrt{\varepsilon}\sqrt{\alpha_3-\omega^2\alpha_4}}$, c_1 and c_2 indicates arbitrary constants.

As c_1 and c_2 are arbitrary constants, one may freely pick their values. Thus, if we accept $c_1 = (-1 + \omega^2)$ and $c_2 = \varepsilon(\alpha_3 - \omega^2\alpha_4)$, then from Eq. (4.1.140), we find the subsequent solution to the strain wave equation in microstructured solids for non-dissipative case (4.1.124):

$$u_{1,45}(x, t) = -\frac{(-1 + \omega^2)}{2\varepsilon\alpha_1} \left\{ -2 + 3 \operatorname{sech}^2 \left(\frac{(x - t\omega)\sqrt{-1 + \omega^2}}{2\sqrt{\varepsilon}\sqrt{\alpha_3 - \omega^2\alpha_4}} \right) \right\}. \tag{4.1.141}$$

Additionally, if we accept $c_1 = (-1 + \omega^2)$ and $c_2 = -\varepsilon(\alpha_3 - \omega^2\alpha_4)$, then from close-form solution (4.1.140), we derived the following solitary wave solution to the strain wave equation in microstructured solids for non-dissipative case:

$$u_{1,46}(x, t) = \frac{(-1 + \omega^2)}{2\varepsilon\alpha_1} \left\{ 2 + 3 \operatorname{csch}^2 \left(\frac{(x - t\omega)\sqrt{-1 + \omega^2}}{2\sqrt{\varepsilon}\sqrt{\alpha_3 - \omega^2\alpha_4}} \right) \right\}. \tag{4.1.142}$$

On the contrary, if we opt $c_1 = (-1 + \omega^2)$ and $c_2 = \pm i \varepsilon(\alpha_3 - \omega^2\alpha_4)$, then from exact solution (4.1.140), we explore the following solution to the strain wave equation in microstructured solids for non-dissipative case:

$$\begin{aligned}
u_{1,47}(x, t) = & -\frac{(-1 + \omega^2)}{2\varepsilon\alpha_1} \operatorname{csc}^2 \left(\frac{\pi}{4} - \frac{(x - t\omega)\sqrt{-1 + \omega^2}}{2\sqrt{\varepsilon}\sqrt{-\alpha_3 + \omega^2\alpha_4}} \right) \\
& \times \left\{ 2 + \sin \left(\frac{(x - t\omega)\sqrt{-1 + \omega^2}}{\sqrt{\varepsilon}\sqrt{-\alpha_3 + \omega^2\alpha_4}} \right) \right\}. \tag{4.1.143}
\end{aligned}$$

In addition of that, if we opt $c_1 = (-1 + \omega^2)$ and $c_2 = \mp i \varepsilon (\alpha_3 - \omega^2 \alpha_4)$, then from solution (4.1.140), we evaluate the solitary wave solution to the strain wave equation in microstructured solids for non-dissipative case:

$$\begin{aligned}
u_{1,48}(x, t) = & -\frac{(-1 + \omega^2)}{2\varepsilon\alpha_1} \operatorname{csc}^2 \left(\frac{\pi}{4} + \frac{(x - t\omega)\sqrt{-1 + \omega^2}}{2\sqrt{\varepsilon}\sqrt{-\alpha_3 + \omega^2\alpha_4}} \right) \\
& \times \left\{ -2 + \sin \left(\frac{(x - t\omega)\sqrt{-1 + \omega^2}}{\sqrt{\varepsilon}\sqrt{-\alpha_3 + \omega^2\alpha_4}} \right) \right\}. \tag{4.1.144}
\end{aligned}$$

4.1(f)-II: The Dissipative Case

The Eq. (4.1.123) is dissipative for $\gamma \neq 0$. When $\delta = \gamma = O(\varepsilon)$, the stability between nonlinearity, dispersion and dissipation, perturbed by the higher order dissipative terms to the strain wave equation in microstructured solids. The higher order dissipative terms be omitted for $\varepsilon \rightarrow 0$, the strain wave equation in microstructured solids for dissipative case can be written as (Pastrone, 2009; Pastrone et al., 2004; Porubov and Pastrone, 2004; Samsonov, 2001),

$$u_{tt} - u_{xx} - \varepsilon \{ \alpha_1 (u^2)_{xx} + \alpha_2 u_{xxt} - \alpha_3 u_{xxxx} + \alpha_4 u_{xxtt} \} = 0. \tag{4.1.145}$$

To construct the exact solutions to the strain wave equation in microstructured solids for dissipative case (4.1.145) by the MSE method, we have used the traveling wave variable (4.1.7).

Then the operation the wave transformation (4.1.7) reduces Eq. (4.1.145) to the following ODE:

$$(\omega^2 - 1) U'' - \varepsilon\{\alpha_1 (U^2)'' - \omega \alpha_2 U''' - (\alpha_3 - \omega^2 \alpha_4) U^{(iv)}\} = 0, \quad (4.1.146)$$

where the prime indicates the derivatives with respect to ξ . Integrate twice the Eq. (4.1.146) with respect to ξ and then we get a new ODE:

$$(\omega^2 - 1) U - \varepsilon\{\alpha_1 U^2 - \omega \alpha_2 U' - (\alpha_3 - \omega^2 \alpha_4) U''\} = 0. \quad (4.1.147)$$

Now, standardized balancing the nonlinear highest order term U^2 and the highest order derivative term U'' of the ODE (4.1.147), yields $N = 2$. So, the solution of Eq. (4.1.147) regard as the type, similar to the Eq. (4.1.1).

Therefore, we may use the values of U , U' and U'' from the Eq. (4.1.1)-(4.1.3) into Eq. (4.1.147), and executing the parallel course of algorithm discussed in Sub-section 4.1(a) yields a set of simultaneous algebraic and differential equations for a_0 , a_1 , a_2 , $\psi(\xi)$ and additional essential parameters, which are given in the following:

$$a_0(-1 + \omega^2 - \varepsilon a_0 \alpha_1) = 0. \quad (4.1.148)$$

$$a_1\{(-1 + \omega^2 - 2\varepsilon a_0 \alpha_1)\psi' + \varepsilon \omega \alpha_2 \psi'' + \varepsilon(\alpha_3 - \omega^2 \alpha_4)\psi'''\} = 0. \quad (4.1.149)$$

$$\begin{aligned} -\varepsilon a_1 \psi' \{(a_1 \alpha_1 + \omega \alpha_2)\psi' + 3(\alpha_3 - \omega^2 \alpha_4)\psi''\} \\ + a_2 [(-1 + \omega^2 - 2\varepsilon a_0 \alpha_1)(\psi')^2 + 2\varepsilon(\alpha_3 - \omega^2 \alpha_4)(\psi'')^2 \\ + 2\varepsilon \psi' \{\omega \alpha_2 \psi'' + (\alpha_3 - \omega^2 \alpha_4)\psi'''\}] = 0. \end{aligned} \quad (4.1.150)$$

$$\begin{aligned} -2\varepsilon a_1 (a_2 \alpha_1 - \alpha_3 + \omega^2 \alpha_4)(\psi')^3 \\ -2\varepsilon a_2 \{\omega \alpha_2 \psi' + 5(\alpha_3 - \omega^2 \alpha_4)\psi''\}(\psi')^2 = 0. \end{aligned} \quad (4.1.151)$$

$$-\varepsilon a_2 (a_2 \alpha_1 - 6\alpha_3 + 6\omega^2 \alpha_4)(\psi')^4 = 0. \quad (4.1.152)$$

Now, we solve these algebraic and differential equations with the help of symbolic computation software for instance, Mathematica. From Eqs. (4.1.148) and (4.1.152), we evaluate

$$a_0 = 0, \quad \frac{-1 + \omega^2}{\varepsilon \alpha_1}$$

and

$$a_2 = \frac{6(\alpha_3 - \omega^2 \alpha_4)}{\alpha_1}, \quad \text{since } a_2 \neq 0.$$

Then from Eq. (4.1.151), we have

$$\psi(\xi) = c_2 + \frac{30c_1(\alpha_3 - \omega^2 \alpha_4)}{-5a_1\alpha_1 - 6\omega\alpha_2} e^{\frac{\xi(-5a_1\alpha_1 - 6\omega\alpha_2)}{30(\alpha_3 - \omega^2 \alpha_4)}}, \quad (4.1.153)$$

where c_1 and c_2 are integration constants.

For the values of a_0 , the following two cases arise:

Case 1: When $a_0 = 0$, then by an accurate exploitation, From Eqs. (4.1.149) and (4.1.150), we evaluate

$$a_1 = 0, \quad \omega = \begin{cases} \pm \frac{\sqrt{\frac{6\varepsilon\alpha_2^2 - 25(\alpha_3 + \alpha_4) + \sqrt{-2500\alpha_3\alpha_4 + \{6\varepsilon\alpha_2^2 - 25(\alpha_3 + \alpha_4)\}^2}}{\alpha_4}}}{5\sqrt{2}} = \pm\theta_1 \text{ (say)} \\ \pm \frac{\sqrt{\frac{-6\varepsilon\alpha_2^2 + 25(\alpha_3 + \alpha_4) + \sqrt{-2500\alpha_3\alpha_4 + \{6\varepsilon\alpha_2^2 - 25(\alpha_3 + \alpha_4)\}^2}}{\alpha_4}}}{5\sqrt{2}} = \pm\theta_2 \text{ (say);} \end{cases}$$

$$a_1 = \frac{3 \left[3\varepsilon\omega\alpha_1\alpha_2 + 5\sqrt{\varepsilon\alpha_1^2 \{ \varepsilon\omega^2\alpha_2^2 + 4(-1 + \omega^2)(-\alpha_3 + \omega^2\alpha_4) \}} \right]}{5\varepsilon\alpha_1^2},$$

$$\omega = -\frac{\sqrt{25 + \frac{6\varepsilon\alpha_2^2}{\alpha_4} + \frac{25\alpha_3}{\alpha_4} \pm \frac{\sqrt{(-6\varepsilon\alpha_2^2 - 25\alpha_3 - 25\alpha_4)^2 - 2500\alpha_3\alpha_4}}{\alpha_4}}}{5\sqrt{2}};$$

and

$$a_1 = \frac{3 \left[3\varepsilon\omega\alpha_1\alpha_2 - 5\sqrt{\varepsilon\alpha_1^2 \{ \varepsilon\omega^2\alpha_2^2 + 4(-1 + \omega^2)(-\alpha_3 + \omega^2\alpha_4) \}} \right]}{5\varepsilon\alpha_1^2},$$

$$\omega = \frac{\sqrt{25 + \frac{6\varepsilon\alpha_2^2}{\alpha_4} + \frac{25\alpha_3}{\alpha_4} \pm \frac{\sqrt{(-6\varepsilon\alpha_2^2 - 25\alpha_3 - 25\alpha_4)^2 - 2500\alpha_3\alpha_4}}{\alpha_4}}}{5\sqrt{2}}.$$

When $a_1 \neq 0$, it is very much unsmooth to extract the values ω , $\psi(\xi)$ and finally the solution form of (4.1.1) is extremely frightful and putrefy. So, we have overridden this case and discussed only the case $a_1 = 0$.

For the case $a_1 = 0$, then from Eq. (4.1.153), we have

$$\psi(\xi) = c_2 - \frac{5e^{-\frac{\xi\omega\alpha_2}{5(\alpha_3 - \omega^2\alpha_4)}} c_1 (\alpha_3 - \omega^2\alpha_4)}{\omega\alpha_2}$$

where $\omega = \pm\theta_1$ or $\omega = \pm\theta_2$; c_1 and c_2 are integration constants.

We substituting the values of a_0 , a_1 , a_2 and $\psi(\xi)$ in Eq. (4.1.1) and then we get the subsequent exponential solution of the ODE (4.1.147):

$$U(\xi) = \frac{6\omega^2 c_1^2 \alpha_2^2 (-\alpha_3 + \omega^2 \alpha_4)}{\alpha_1 \left\{ \omega c_2 \alpha_2 e^{\frac{\xi\omega\alpha_2}{5\alpha_3 - 5\omega^2\alpha_4}} - 5c_1 (\alpha_3 - \omega^2 \alpha_4) \right\}^2}, \quad (4.1.154)$$

where $\omega = \pm\theta_1$ or $\omega = \pm\theta_2$.

Simplifying the solution (4.1.154), we obtain the subsequent hyperbolic solution to the strain wave equation in microstructured solids for dissipative case (4.1.145):

$$\begin{aligned} u(x, t) = & \left[6\omega^2 c_1^2 \alpha_2^2 (-\alpha_3 + \omega^2 \alpha_4) \right. \\ & \times \left\{ \sinh \left(\frac{\omega(x - t\omega)\alpha_2}{5\alpha_3 - 5\omega^2\alpha_4} \right) - \cosh \left(\frac{\omega(x - t\omega)\alpha_2}{5\alpha_3 - 5\omega^2\alpha_4} \right) \right\} \Big] \\ & / \left(\alpha_1 \left[\omega \left\{ \cosh \left(\frac{\omega(x - t\omega)\alpha_2}{10(\alpha_3 - \omega^2\alpha_4)} \right) + \sinh \left(\frac{\omega(x - t\omega)\alpha_2}{10(\alpha_3 - \omega^2\alpha_4)} \right) \right\} c_2 \alpha_2 \right. \right. \\ & \left. \left. + 5 \left\{ -\cosh \left(\frac{\omega(x - t\omega)\alpha_2}{10(\alpha_3 - \omega^2\alpha_4)} \right) + \sinh \left(\frac{\omega(x - t\omega)\alpha_2}{10(\alpha_3 - \omega^2\alpha_4)} \right) \right\} \right. \right. \\ & \left. \left. \times c_1 (\alpha_3 - \omega^2 \alpha_4) \right]^2 \right), \quad (4.1.155) \end{aligned}$$

where $\omega = \pm\theta_1$ or $\omega = \pm\theta_2$; c_1 and c_2 signify arbitrary constants. Since c_1 and c_2 are arbitrary constants, we may freely pick their values. Hence, if we pick $c_1 = \alpha_2\omega$ and $c_2 = -5(\alpha_3 - \omega^2\alpha_4)$, then from Eq. (4.1.155), we obtain the following solution to the strain wave equation for dissipative case:

$$u_{1,49}(x, t) = \frac{3\omega^2\alpha_2^2}{50\alpha_1(\alpha_3 - \omega^2\alpha_4)} \left\{ 1 + \tanh\left(\frac{\omega(-x + t\omega)\alpha_2}{10(\alpha_3 - \omega^2\alpha_4)}\right) \right\}^2, \quad (4.1.156)$$

where $\omega = \pm\theta_1$ or $\omega = \pm\theta_2$.

Moreover, if we take $c_1 = \alpha_2\omega$ and $c_2 = 5(\alpha_3 - \omega^2\alpha_4)$, then from exact solution (4.1.155), we calculate the subsequent solitary wave solution to the strain wave equation in microstructured solids for non-dissipative case:

$$u_{1,50}(x, t) = \frac{3\omega^2\alpha_2^2}{50\alpha_1(\alpha_3 - \omega^2\alpha_4)} \left\{ 1 + \coth\left(\frac{\omega(-x + t\omega)\alpha_2}{10(\alpha_3 - \omega^2\alpha_4)}\right) \right\}^2, \quad (4.1.157)$$

where $\omega = \pm\theta_1$ or $\omega = \pm\theta_2$.

Case 2: When $a_0 = \frac{-1+\omega^2}{\varepsilon\alpha_1}$, then by a exact exploitation, From Eqs. (4.1.149) and (4.1.150), we obtain

$$\alpha_1 = 0, \quad \omega = \begin{cases} \pm \frac{\sqrt{\frac{6\varepsilon\alpha_2^2+25\alpha_3+25\alpha_4 - \sqrt{-2500\alpha_3\alpha_4+(6\varepsilon\alpha_2^2+25(\alpha_3+\alpha_4))^2}}{\alpha_4}}}{5\sqrt{2}} = \pm\vartheta_1 \text{ (say)} \\ \pm \frac{\sqrt{\frac{6\varepsilon\alpha_2^2+25\alpha_3+25\alpha_4 + \sqrt{-2500\alpha_3\alpha_4+(6\varepsilon\alpha_2^2+25(\alpha_3+\alpha_4))^2}}{\alpha_4}}}{5\sqrt{2}} = \pm\vartheta_2 \text{ (say);} \end{cases}$$

$$\alpha_1 = \frac{3 \left[3\varepsilon\omega\alpha_1\alpha_2 + 5\sqrt{\varepsilon\alpha_1^2\{\varepsilon\omega^2\alpha_2^2 + 4(-1 + \omega^2)(\alpha_3 - \omega^2\alpha_4)\}} \right]}{5\varepsilon\alpha_1^2},$$

$$\omega = -\frac{\sqrt{\frac{-6\varepsilon\alpha_2^2+25\alpha_3+25\alpha_4 \pm \sqrt{-2500\alpha_3\alpha_4+\{6\varepsilon\alpha_2^2-25(\alpha_3+\alpha_4)\}^2}}{\alpha_4}}}{5\sqrt{2}}$$

and

$$a_1 = \frac{3 \left[3\varepsilon\omega\alpha_1\alpha_2 - 5\sqrt{\varepsilon\alpha_1^2\{\varepsilon\omega^2\alpha_2^2 + 4(-1 + \omega^2)(\alpha_3 - \omega^2\alpha_4)\}} \right]}{5\varepsilon\alpha_1^2},$$

$$\omega = \frac{\sqrt{\frac{-6\varepsilon\alpha_2^2 + 25\alpha_3 + 25\alpha_4 \pm \sqrt{-2500\alpha_3\alpha_4 + \{6\varepsilon\alpha_2^2 - 25(\alpha_3 + \alpha_4)\}^2}}{\alpha_4}}}{5\sqrt{2}}.$$

When $a_1 \neq 0$, it is immensely haughty to extract the values ω , $\psi(\xi)$ and finally the solution form of (4.1.1) is really tremendous and putrefy. So, we have ignored this case and discussed only the case $a_1 = 0$.

For the case $a_1 = 0$, then from Eq. (4.1.153), we get

$$\psi(\xi) = c_2 - \frac{5c_1(\alpha_3 - \omega^2\alpha_4)}{\omega\alpha_2} e^{-\frac{\xi\omega\alpha_2}{5(\alpha_3 - \omega^2\alpha_4)}}$$

where $\omega = \pm\vartheta_1$ or $\omega = \pm\vartheta_2$; c_1 and c_2 are integration constants.

At this time we substitute the values of a_0 , a_1 , a_2 and $\psi(\xi)$ in Eq. (4.1.1) and then we occur the exponential solution of the ODE (4.1.147):

$$U(\xi) = \frac{-1 + \omega^2}{\varepsilon\alpha_1} - \frac{6\omega^2 c_1^2 \alpha_2^2 (-\alpha_3 + \omega^2 \alpha_4)}{\alpha_1 \left\{ \omega c_2 \alpha_2 e^{\frac{\xi\omega\alpha_2}{5\alpha_3 - 5\omega^2\alpha_4}} - 5c_1(\alpha_3 - \omega^2\alpha_4) \right\}^2}, \quad (4.1.158)$$

where $\omega = \pm\vartheta_1$ or $\omega = \pm\vartheta_2$.

Upon simplification the exponential solution (4.1.158), we explore the following hyperbolic solution to the strain wave equation in microstructured solids for dissipative case (4.1.145):

$$\begin{aligned}
u(x, t) = & \left[\omega^2(-1 + \omega^2) \left\{ \cosh\left(\frac{\omega(x-t\omega)\alpha_2}{5\alpha_3 - 5\omega^2\alpha_4}\right) + \sinh\left(\frac{\omega(x-t\omega)\alpha_2}{5\alpha_3 - 5\omega^2\alpha_4}\right) \right\} c_2^2 \alpha_2^2 \right. \\
& + 10\omega(-1 + \omega^2) c_1 c_2 \alpha_2 (-\alpha_3 + \omega^2 \alpha_4) \\
& + \left\{ \cosh\left(\frac{\omega(x-t\omega)\alpha_2}{5\alpha_3 - 5\omega^2\alpha_4}\right) - \sinh\left(\frac{\omega(x-t\omega)\alpha_2}{5\alpha_3 - 5\omega^2\alpha_4}\right) \right\} \\
& \times c_1^2 (\alpha_3 - \omega^2 \alpha_4) \{ 6\varepsilon \omega^2 \alpha_2^2 - 25(-1 + \omega^2) (-\alpha_3 + \omega^2 \alpha_4) \} \\
& / \left(\varepsilon \alpha_1 \left[\omega \left\{ \cosh\left(\frac{\omega(x-t\omega)\alpha_2}{10(\alpha_3 - \omega^2 \alpha_4)}\right) + \sinh\left(\frac{\omega(x-t\omega)\alpha_2}{10(\alpha_3 - \omega^2 \alpha_4)}\right) \right\} c_2 \alpha_2 \right. \right. \\
& + 5 \left\{ -\cosh\left(\frac{\omega(x-t\omega)\alpha_2}{10(\alpha_3 - \omega^2 \alpha_4)}\right) + \sinh\left(\frac{\omega(x-t\omega)\alpha_2}{10(\alpha_3 - \omega^2 \alpha_4)}\right) \right\} \\
& \left. \left. \times c_1 (\alpha_3 - \omega^2 \alpha_4) \right]^2 \right), \tag{4.1.159}
\end{aligned}$$

where $\omega = \pm\vartheta_1$ or $\omega = \pm\vartheta_2$; c_1 and c_2 define arbitrary constants. Since c_1 and c_2 are arbitrary constants, one may autonomously opt their values. If we opt $c_1 = \alpha_2 \omega$ and $c_2 = -5(\alpha_3 - \omega^2 \alpha_4)$, then from Eq. (4.1.159), we evaluated the subsequent solution to the strain wave equation in microstructured solids for dissipative case:

$$u_{1,51}(x, t) = \frac{(-1 + \omega^2)}{\varepsilon \alpha_1} + \frac{3\varepsilon \omega^2 \alpha_2^2 \left\{ -1 + \tanh\left(\frac{\omega(x-t\omega)\alpha_2}{10(\alpha_3 - \omega^2 \alpha_4)}\right) \right\}^2}{50\varepsilon \alpha_1 (\alpha_3 - \omega^2 \alpha_4)}, \tag{4.1.160}$$

where $\omega = \pm\vartheta_1$ or $\omega = \pm\vartheta_2$.

Furthermore, if we choose $c_1 = \alpha_2 \omega$ and $c_2 = 5(\alpha_3 - \omega^2 \alpha_4)$, then from exact solution (4.1.159), we explore the following solution to the strain wave equation in microstructured solids for dissipative case:

$$u_{1,52}(x, t) = \frac{(-1 + \omega^2)}{\alpha_1 \varepsilon} - \frac{3\omega^2 \left\{ -1 + \coth\left(\frac{\omega(x-t\omega)\alpha_2}{10(\alpha_3 - \omega^2 \alpha_4)}\right) \right\}^2 \alpha_2^2}{50\alpha_1 (-\alpha_3 + \omega^2 \alpha_4)}, \tag{4.1.161}$$

where $\omega = \pm\vartheta_1$ or $\omega = \pm\vartheta_2$.

Remark 4.1(f): The solutions (4.1.135)-(4.1.138) and (4.1.141)-(4.1.144) have been verified by putting them back into the original equation (4.1.124) and predictable correct. Also, the solutions (4.1.156)-(4.1.157), where $\omega = \pm\theta_1$ or $\omega = \pm\theta_2$ and the solutions (4.1.160)-(4.1.161) where, $\omega = \pm\vartheta_1$ or $\omega = \pm\vartheta_2$ have been established by putting them reverse into the original equation (4.1.145) and found truthful.

4.2: Applications of the (G'/G) -expansion Method

In this section, we have written down the solutions to the equations evaluated in Section 4.1, obtained by some researchers through the (G'/G) -expansion method. Wang et al. (Wang et al., 2008a) developed the method and then many researchers worked on this method. For balance number two, the solution (3.2.4) takes the following shape:

$$U(\xi) = a_0 + a_1 \left(\frac{G'}{G} \right) + a_2 \left(\frac{G'}{G} \right)^2, \quad (4.2.1)$$

where $G = G(\xi)$ satisfies the following second order linear ODE in the form:

$$G''(\xi) + \lambda G'(\xi) + \mu G(\xi) = 0, \quad (4.2.2)$$

where a_0, a_1, a_2, λ and μ are constants to be determined, but $a_2 \neq 0$.

Differentiating the solution (4.2.1) with respect to the wave variable ξ , first to fourth time respectively and also using the linear ODE (4.2.2) to build up the polynomial of $\left(\frac{G'}{G} \right)$:

$$U'(\xi) = -\mu a_1 - (\lambda a_1 + 2\mu a_2) \left(\frac{G'}{G} \right) - (a_1 + 2\lambda a_2) \left(\frac{G'}{G} \right)^2 - 2a_2 \left(\frac{G'}{G} \right)^3. \quad (4.2.3)$$

$$\begin{aligned} U''(\xi) &= \lambda\mu a_1 + 2\mu^2 a_2 + (\lambda^2 a_1 + 2\mu a_1 + 6\lambda\mu a_2) \left(\frac{G'}{G} \right) \\ &\quad + (3\lambda a_1 + 4\lambda^2 a_2 + 8\mu a_2) \left(\frac{G'}{G} \right)^2 + (2a_1 + 10\lambda a_2) \left(\frac{G'}{G} \right)^3 \\ &\quad + 6a_2 \left(\frac{G'}{G} \right)^4. \end{aligned} \quad (4.2.4)$$

$$\begin{aligned}
U'''(\xi) = & -(\lambda^2\mu a_1 + 2\mu^2 a_1 + 6\lambda\mu^2 a_2) \\
& - (\lambda^3 a_1 + 8\lambda\mu a_1 + 14\lambda^2\mu a_2 + 16\mu^2 a_2) \left(\frac{G'}{G}\right) \\
& - (7\lambda^2 a_1 + 8\mu a_1 + 8\lambda^3 a_2 + 52\lambda\mu a_2) \left(\frac{G'}{G}\right)^2 \\
& - (12\lambda a_1 + 38\lambda^2 a_2 + 40\mu a_2) \left(\frac{G'}{G}\right)^3 - (6a_1 + 54\lambda a_2) \left(\frac{G'}{G}\right)^4 \\
& - 24a_2 \left(\frac{G'}{G}\right)^5. \tag{4.2.5}
\end{aligned}$$

$$\begin{aligned}
U^{(iv)}(\xi) = & (\lambda^3\mu a_1 + 8\lambda\mu^2 a_1 + 14\lambda^2\mu^2 a_2 + 16\mu^3 a_2) \\
& + (\lambda^4 a_1 + 22\lambda^2\mu a_1 + 16\mu^2 a_1 + 30\lambda^3\mu a_2 + 120\lambda\mu^2 a_2) \left(\frac{G'}{G}\right) \\
& + (15\lambda^3 a_1 + 60\lambda\mu a_1 + 16\lambda^4 a_2 + 232\lambda^2\mu a_2 + 136\mu^2 a_2) \left(\frac{G'}{G}\right)^2 \\
& + (50\lambda^2 a_1 + 40\mu a_1 + 130\lambda^3 a_2 + 440\lambda\mu a_2) \left(\frac{G'}{G}\right)^3 \\
& + (60\lambda a_1 + 330\lambda^2 a_2 + 240\mu a_2) \left(\frac{G'}{G}\right)^4 + (24a_1 + 336\lambda a_2) \left(\frac{G'}{G}\right)^5 \\
& + 120a_2 \left(\frac{G'}{G}\right)^6. \tag{4.2.6}
\end{aligned}$$

Since G satisfies the ODE (4.2.2), so that $\left(\frac{G'}{G}\right)$ is a predefined function and $\left(\frac{G'}{G}\right)$ contains the values of the solutions (3.2.6)-(3.2.8) to the ODE (4.2.2) in Chapter 3.

4.2(a): The KdV Equation

In this sub-section, we have written down to previous analytical exact solutions to the KdV equation obtained via the (G'/G) -expansion method by Wang et al. (Wang et al., 2008a). Wang et al. considered the KdV equation in the form:

$$u_t + u u_x + \delta u_{xxx} = 0, \quad (4.2.7)$$

where δ is a real constant. They used the following travelling wave variable

$$u(x, t) = U(\xi), \quad \xi = x - \omega t, \quad (4.2.8)$$

and they obtained the following family of exact solutions to the KdV equation (4.2.7) by using the (G'/G) -expansion method:

Family 1: When $\lambda^2 - 4\mu > 0$,

$$u(x, t) = -3\delta(\lambda^2 - 4\mu) \times \left\{ \frac{B \cosh\left(\frac{\sqrt{\lambda^2 - 4\mu}(x - t\omega)}{2}\right) + A \sinh\left(\frac{\sqrt{\lambda^2 - 4\mu}(x - t\omega)}{2}\right)}{A \cosh\left(\frac{\sqrt{\lambda^2 - 4\mu}(x - t\omega)}{2}\right) + B \sinh\left(\frac{\sqrt{\lambda^2 - 4\mu}(x - t\omega)}{2}\right)} \right\}^2 + 3\delta\lambda^2 + a_0, \quad (4.2.9)$$

where $\omega = \delta\lambda^2 + 8\delta\mu + a_0$, A and B are arbitrary constants.

Family 2: When $\lambda^2 - 4\mu < 0$,

$$u(x, t) = -3\delta(4\mu - \lambda^2) \times \left\{ \frac{B \cos\left(\frac{\sqrt{4\mu - \lambda^2}(x - t\omega)}{2}\right) - A \sin\left(\frac{\sqrt{4\mu - \lambda^2}(x - t\omega)}{2}\right)}{A \cos\left(\frac{\sqrt{4\mu - \lambda^2}(x - t\omega)}{2}\right) + B \sin\left(\frac{\sqrt{4\mu - \lambda^2}(x - t\omega)}{2}\right)} \right\}^2 + 3\delta\lambda^2 + a_0, \quad (4.2.10)$$

where $\omega = \delta\lambda^2 + 8\delta\mu + a_0$, A and B are arbitrary constants.

Family 3: When $\lambda^2 - 4\mu = 0$,

$$u(x, t) = -12\delta \left\{ \frac{B}{A + B(x - t\omega)} \right\}^2 + 3\delta\lambda^2 + a_0, \quad (4.2.11)$$

where $\omega = 3\delta\lambda^2 + a_0$, A and B are arbitrary constants.

Since A and B are arbitrary constants, one may arbitrarily pick their values. At this moment, the choice of the values of A and B produce some special solutions. If $B = 0$ when $A \neq 0$, then the subsequent solitary solutions from (4.2.9) and (4.2.10) can be obtained respectively:

$$u_{2,1}(x, t) = 12\delta\mu + a_0 + 3\delta(\lambda^2 - 4\mu) \operatorname{sech}^2 \left(\frac{1}{2} \sqrt{\lambda^2 - 4\mu}(x - t\omega) \right), \quad (4.2.12)$$

$$u_{2,2}(x, t) = 12\delta\mu + a_0 - 3\delta(4\mu - \lambda^2) \operatorname{sec}^2 \left(\frac{1}{2} \sqrt{4\mu - \lambda^2}(x - t\omega) \right), \quad (4.2.13)$$

where $\omega = \delta\lambda^2 + 8\delta\mu + a_0$.

Also if $B = 0$ when $A \neq 0$, then the following solutions from the solutions (4.2.9) and (4.2.10) become respectively:

$$u_{2,3}(x, t) = 12\delta\mu + a_0 - 3\delta(\lambda^2 - 4\mu) \operatorname{csch}^2 \left(\frac{1}{2} (x - t\omega) \sqrt{\lambda^2 - 4\mu} \right), \quad (4.2.14)$$

$$u_{2,4}(x, t) = 12\delta\mu + a_0 + 3\delta(\lambda^2 - 4\mu) \operatorname{csc}^2 \left(\frac{1}{2} (x - t\omega) \sqrt{4\mu - \lambda^2} \right), \quad (4.2.15)$$

where $\omega = \delta\lambda^2 + 8\delta\mu + a_0$.

4.2(b): The Boussinesq Equation

Bekir (Bekir, 2008) considered the Boussinesq equation:

$$u_{tt} - u_{xx} - (u^2)_{xx} + u_{xxxx} = 0, \quad (4.2.16)$$

while he used the travelling wave variable similar to (4.2.8) and then by using the (G'/G) -expansion method he found a set of travelling wave solutions as shown below:

Set 1: When $\lambda^2 - 4\mu > 0$,

$$u(x, t) = \left\{ \frac{B \cosh \left(\frac{1}{2} \sqrt{\lambda^2 - 4\mu}(x - t\omega) \right) + A \sinh \left(\frac{1}{2} \sqrt{\lambda^2 - 4\mu}(x - t\omega) \right)}{A \cosh \left(\frac{1}{2} \sqrt{\lambda^2 - 4\mu}(x - t\omega) \right) + B \sinh \left(\frac{1}{2} \sqrt{\lambda^2 - 4\mu}(x - t\omega) \right)} \right\}^2 \times \frac{3}{2} (\lambda^2 - 4\mu) - \frac{3}{2} \lambda^2 + 6\mu, \quad (4.2.17)$$

where $\omega = \sqrt{1 - \lambda^2 + 4\mu}$.

And

$$u(x, t) = \left\{ \frac{B \cosh\left(\frac{1}{2}\sqrt{\lambda^2 - 4\mu}(x - t\omega)\right) + A \sinh\left(\frac{1}{2}\sqrt{\lambda^2 - 4\mu}(x - t\omega)\right)}{A \cosh\left(\frac{1}{2}\sqrt{\lambda^2 - 4\mu}(x - t\omega)\right) + B \sinh\left(\frac{1}{2}\sqrt{\lambda^2 - 4\mu}(x - t\omega)\right)} \right\}^2$$

$$\times \frac{3}{2}(\lambda^2 - 4\mu) - \frac{3}{2}\lambda^2 + \lambda^2 + 2\mu, \quad (4.2.18)$$

where $\omega = \sqrt{1 + \lambda^2 - 4\mu}$, A and B are arbitrary constants.

Set 2: When $\lambda^2 - 4\mu < 0$,

$$u(x, t) = \left\{ \frac{B \cos\left(\frac{1}{2}\sqrt{4\mu - \lambda^2}(x - t\omega)\right) - A \sin\left(\frac{1}{2}\sqrt{4\mu - \lambda^2}(x - t\omega)\right)}{A \cos\left(\frac{1}{2}\sqrt{4\mu - \lambda^2}(x - t\omega)\right) + B \sin\left(\frac{1}{2}\sqrt{4\mu - \lambda^2}(x - t\omega)\right)} \right\}^2$$

$$\times \frac{3}{2}(4\mu - \lambda^2) - \frac{3}{2}\lambda^2 + 6\mu, \quad (4.2.19)$$

where $\omega = \sqrt{1 - \lambda^2 + 4\mu}$.

And

$$u(x, t) = \left\{ \frac{B \cos\left(\frac{1}{2}\sqrt{4\mu - \lambda^2}(x - t\omega)\right) - A \sin\left(\frac{1}{2}\sqrt{4\mu - \lambda^2}(x - t\omega)\right)}{A \cos\left(\frac{1}{2}\sqrt{4\mu - \lambda^2}(x - t\omega)\right) + B \sin\left(\frac{1}{2}\sqrt{4\mu - \lambda^2}(x - t\omega)\right)} \right\}^2$$

$$\times \frac{3}{2}(4\mu - \lambda^2) - \frac{3}{2}\lambda^2 + \lambda^2 + 2\mu, \quad (4.2.20)$$

where $\omega = \sqrt{1 + \lambda^2 - 4\mu}$, A and B are arbitrary constants.

Set 3: When $\lambda^2 - 4\mu = 0$,

$$u(x, t) = 6 \left\{ \frac{B}{A + B(x - t\omega)} \right\}^2 - \frac{3}{2}\lambda^2 + 6\mu, \quad (4.2.21)$$

where $\omega = \sqrt{1 - \lambda^2 + 4\mu}$.

And

$$u(x, t) = 6 \left\{ \frac{B}{A + B(x - t\omega)} \right\}^2 - \frac{3}{2}\lambda^2 + \lambda^2 + 2\mu, \quad (4.2.22)$$

where $\omega = \sqrt{1 + \lambda^2 - 4\mu}$, A and B are arbitrary constants.

In particular, if $A \neq 0$, $B = 0$, then the solitary wave solutions (4.2.17) and (4.2.18) of the Boussinesq equation was constructed by Bekir as follows:

$$u_{2,5}(x, t) = -\frac{3}{2}(\lambda^2 - 4\mu) \operatorname{sech}^2\left(\frac{1}{2}\sqrt{\lambda^2 - 4\mu}(x - t\omega)\right), \quad (4.2.23)$$

where $\omega = \sqrt{1 - \lambda^2 + 4\mu}$.

And

$$u_{2,6}(x, t) = (\lambda^2 - 4\mu) - \frac{3(\lambda^2 - 4\mu)}{2} \operatorname{sech}^2\left(\frac{\sqrt{\lambda^2 - 4\mu}}{2}(x - t\omega)\right), \quad (4.2.24)$$

where $\omega = \sqrt{1 + \lambda^2 - 4\mu}$.

Since A and B are arbitrary constants then their values can be randomly chosen. At this instant, if $A \neq 0$, $B = 0$, then the ensuing solutions (4.2.19) and (4.2.20), respectively become:

$$u_{2,7}(x, t) = -\frac{3}{2}(\lambda^2 - 4\mu) \operatorname{sec}^2\left(\frac{1}{2}\sqrt{4\mu - \lambda^2}(x - t\omega)\right), \quad (4.2.25)$$

where $\omega = \sqrt{1 - \lambda^2 + 4\mu}$.

And

$$u_{2,8}(x, t) = \lambda^2 - 4\mu + \frac{3}{2}(4\mu - \lambda^2) \operatorname{sec}^2\left(\frac{1}{2}(x - t\omega)\sqrt{4\mu - \lambda^2}\right), \quad (4.2.26)$$

where $\omega = \sqrt{1 + \lambda^2 - 4\mu}$.

4.2(c): The Fifth-order KdV Equation

Khan and Akbar (Khan and Akbar, 2015c) considered the following fifth-order KdV equation:

$$u_t + \alpha u u_x + \beta u^2 u_x + \gamma u_{xxx} + \eta u_{xxxxx} = 0, \quad (4.2.27)$$

where α , β , γ and η are the real constants.

By means of the (G'/G) -expansion method, Khan and Akbar (Khan and Akbar, 2015c) obtained the following solutions to the fifth-order KdV equation (4.2.27):

Family 1: When $\lambda^2 - 4\mu > 0$,

$$u(x, t) = -\frac{\alpha}{2\beta} \pm \frac{\{\gamma - 10\eta(\lambda^2 - 4\mu)\}}{\sqrt{10}\sqrt{-\beta}\sqrt{\eta}} \pm \frac{3\sqrt{5}(\lambda^2 - 4\mu)\sqrt{\eta}}{\sqrt{2}\sqrt{-\beta}} \\ \times \left\{ \frac{A \sinh\left(\frac{(x-\omega t)\sqrt{\lambda^2-4\mu}}{2}\right) + B \cosh\left(\frac{(x-\omega t)\sqrt{\lambda^2-4\mu}}{2}\right)}{A \cosh\left(\frac{(x-\omega t)\sqrt{\lambda^2-4\mu}}{2}\right) + B \sinh\left(\frac{(x-\omega t)\sqrt{\lambda^2-4\mu}}{2}\right)} \right\}^2, \quad (4.2.28)$$

where, $\omega = -\frac{5\alpha^2\eta+2\beta\{\gamma^2+15\eta^2(\lambda^2-4\mu)^2\}}{20\beta\eta}$, A and B are arbitrary constants.

Family 2: When $\lambda^2 - 4\mu < 0$,

$$u(x, t) = -\frac{\alpha}{2\beta} \pm \frac{\{\gamma - 10\eta(\lambda^2 - 4\mu)\}}{\sqrt{10}\sqrt{-\beta}\sqrt{\eta}} \pm \frac{3\sqrt{5}(4\mu - \lambda^2)\sqrt{\eta}}{\sqrt{2}\sqrt{-\beta}} \\ \times \left\{ \frac{A \sin\left(\frac{(x-\omega t)\sqrt{4\mu-\lambda^2}}{2}\right) - B \cos\left(\frac{(x-\omega t)\sqrt{4\mu-\lambda^2}}{2}\right)}{A \cos\left(\frac{(x-\omega t)\sqrt{4\mu-\lambda^2}}{2}\right) + B \sin\left(\frac{(x-\omega t)\sqrt{4\mu-\lambda^2}}{2}\right)} \right\}^2, \quad (4.2.29)$$

where, $\omega = -\frac{5\alpha^2\eta+2\beta\{\gamma^2+15\eta^2(\lambda^2-4\mu)^2\}}{20\beta\eta}$, A and B are arbitrary constants.

Family 3: When $\lambda^2 - 4\mu = 0$,

$$u(x, t) = -\frac{\alpha}{2\beta} \pm \frac{6\sqrt{10}\sqrt{\eta}}{\sqrt{-\beta}} \left(\frac{B}{A + B(x - \omega t)} \right)^2, \quad (4.2.30)$$

where, $\omega = -\frac{5\alpha^2\eta+2\beta\gamma^2}{20\beta\eta}$, A and B are arbitrary constants.

Since A and B are arbitrary constants, their values can be put freely. Therefore, if $B = 0$ when $A \neq 0$, then the solitary solutions (4.2.28) and (4.2.29), respectively become:

$$u_{2,9}(x, t) = -\frac{\alpha}{2\beta} \pm \frac{\gamma + 5\eta(\lambda^2 - 4\mu)}{\sqrt{10}\sqrt{-\beta}\sqrt{\eta}} \mp \frac{3\sqrt{5}(\lambda^2 - 4\mu)\sqrt{\eta}}{\sqrt{2}\sqrt{-\beta}}$$

$$\times \operatorname{sech}^2\left(\frac{(x - \omega t)\sqrt{\lambda^2 - 4\mu}}{2}\right), \quad (4.2.31)$$

$$u_{2,10}(x, t) = -\frac{\alpha}{2\beta} \pm \frac{\gamma + 5\eta(\lambda^2 - 4\mu)}{\sqrt{10}\sqrt{-\beta}\sqrt{\eta}} \pm \frac{3\sqrt{5}\sqrt{\eta}(4\mu - \lambda^2)}{\sqrt{2}\sqrt{-\beta}}$$

$$\times \operatorname{sec}^2\left(\frac{(x - \omega t)\sqrt{4\mu - \lambda^2}}{2}\right), \quad (4.2.32)$$

where $\omega = -\frac{5\alpha^2\eta + 2\beta\{\gamma^2 + 15\eta^2(\lambda^2 - 4\mu)^2\}}{20\beta\eta}$, α , β , γ , η , λ and μ are real parameters.

Also if $B = 0$ when $A \neq 0$, it yield the subsequent solutions from (4.2.28) and (4.2.29), respectively:

$$u_{2,11}(x, t) = -\frac{\alpha}{2\beta} \pm \frac{\gamma + 5\eta(\lambda^2 - 4\mu)}{\sqrt{10}\sqrt{-\beta}\sqrt{\eta}} \pm \frac{3\sqrt{5}(\lambda^2 - 4\mu)\sqrt{\eta}}{\sqrt{2}\sqrt{-\beta}}$$

$$\times \operatorname{csch}^2\left(\frac{(x - \omega t)\sqrt{\lambda^2 - 4\mu}}{2}\right), \quad (4.2.33)$$

$$u_{2,12}(x, t) = -\frac{\alpha}{2\beta} \pm \frac{\gamma + 5\eta(\lambda^2 - 4\mu)}{\sqrt{10}\sqrt{-\beta}\sqrt{\eta}} \pm \frac{3\sqrt{5}\sqrt{\eta}(4\mu - \lambda^2)}{\sqrt{2}\sqrt{-\beta}}$$

$$\times \operatorname{csc}^2\left(\frac{(x - \omega t)\sqrt{4\mu - \lambda^2}}{2}\right), \quad (4.2.34)$$

where $\omega = -\frac{5\alpha^2\eta + 2\beta\{\gamma^2 + 15\eta^2(\lambda^2 - 4\mu)^2\}}{20\beta\eta}$, α , β , γ , η , λ and μ are real parameters.

4.2(d): The Modified Schamel Equation for Acoustic Waves in Plasma Physics

Taha et al. (Taha et al., 2013) considered the modified Schamel equation for acoustic waves as follows:

$$u_t + u^{1/2}u_x + \delta u_{xxx} = 0, \quad (4.2.35)$$

where δ is constant. They used the transformations

$$u(x, t) = v^2(x, t), \quad v(x, t) = U(\xi), \quad \xi = kx - \omega t, \quad (4.2.36)$$

it reduces the Eq. (4.2.35) to an ODE and integrating this ODE with respect to ξ , set the integrating constant to zero, they constructed a new ODE:

$$-\omega \frac{U^2}{2} + k \frac{U^3}{3} + \delta k^3 \{(U')^2 + UU''\} = 0. \quad (4.2.37)$$

The balance number of the Eq. (4.2.37) is 2. So, that they took the solution of the ODE (4.2.37) is equivalent to the Eq. (4.2.1) and they obtained

$$U(\xi) = -30k^2\delta\mu - 30k^2\delta\lambda \left(\frac{G'}{G}\right) - 30k^2\delta \left(\frac{G''}{G}\right)^2. \quad (4.2.38)$$

Finally, Taha et al.'s constructed the following solutions to the ODE (4.2.37):

When $D = \lambda^2 - 4\mu > 0$,

$$v(x, t) = -30k^2\delta\mu - 30k^2\delta\lambda \left\{ -\frac{\lambda}{2} + \frac{\sqrt{D}}{2} \times \frac{B \cosh\left(\frac{\sqrt{D}}{2} \xi\right) + A \sinh\left(\frac{\sqrt{D}}{2} \xi\right)}{A \cosh\left(\frac{\sqrt{D}}{2} \xi\right) + B \sinh\left(\frac{\sqrt{D}}{2} \xi\right)} \right\} \\ - 30k^2\delta \left\{ -\frac{\lambda}{2} + \frac{\sqrt{D}}{2} \times \frac{B \cosh\left(\frac{\sqrt{D}}{2} \xi\right) + A \sinh\left(\frac{\sqrt{D}}{2} \xi\right)}{A \cosh\left(\frac{\sqrt{D}}{2} \xi\right) + B \sinh\left(\frac{\sqrt{D}}{2} \xi\right)} \right\}^2. \quad (4.2.39)$$

When $D < 0$,

$$v(x, t) = -30k^2\delta\mu - 30k^2\delta\lambda \left\{ -\frac{\lambda}{2} + \frac{\sqrt{D}}{2} \times \frac{B \cos\left(\frac{\sqrt{D}}{2} \xi\right) - A \sin\left(\frac{\sqrt{D}}{2} \xi\right)}{A \cos\left(\frac{\sqrt{D}}{2} \xi\right) + B \sin\left(\frac{\sqrt{D}}{2} \xi\right)} \right\} \\ - 30k^2\delta \left\{ -\frac{\lambda}{2} + \frac{\sqrt{D}}{2} \times \frac{B \cos\left(\frac{\sqrt{D}}{2} \xi\right) - A \sin\left(\frac{\sqrt{D}}{2} \xi\right)}{A \cos\left(\frac{\sqrt{D}}{2} \xi\right) + B \sin\left(\frac{\sqrt{D}}{2} \xi\right)} \right\}^2. \quad (4.2.40)$$

When $D = 0$,

$$v(x, t) = -30k^2\delta\mu - 30k^2\delta\lambda \left(\frac{B}{A + B\xi} - \frac{\lambda}{2}\right) - 30k^2\delta \left(\frac{B}{A + B\xi} - \frac{\lambda}{2}\right)^2, \quad (4.2.41)$$

where $\xi = x - 4k^3\delta(\lambda^2 - 4\mu)t$ and A and B are arbitrary constants.

Since $u(x, t) = v^2(x, t)$, so Taha et al.'s solutions (4.2.39)-(4.2.41) to the ODE (4.2.37), can be simplified the subsequent solutions to the modified Schamel equation (4.2.35), respectively:

When $\lambda^2 - 4\mu > 0$,

$$u(x, t) = \left[\frac{15}{2}k^2\delta\lambda^2 - 30k^2\delta\mu - \frac{15}{2}k^2\delta(\lambda^2 - 4\mu) \right. \\ \left. \times \left\{ \frac{B \cosh\left(\frac{(kx-t\omega)\sqrt{\lambda^2-4\mu}}{2}\right) + A \sinh\left(\frac{(kx-t\omega)\sqrt{\lambda^2-4\mu}}{2}\right)}{A \cosh\left(\frac{(kx-t\omega)\sqrt{\lambda^2-4\mu}}{2}\right) + B \sinh\left(\frac{(kx-t\omega)\sqrt{\lambda^2-4\mu}}{2}\right)} \right\}^2 \right]^2, \quad (4.2.42)$$

where $\omega = 4k^3\delta(\lambda^2 - 4\mu)$ and A and B are arbitrary constants.

When $\lambda^2 - 4\mu < 0$,

$$u(x, t) = \left[\frac{15}{2}k^2\delta\lambda^2 - 30k^2\delta\mu - \frac{15}{2}k^2\delta(-\lambda^2 + 4\mu) \right. \\ \left. \times \left\{ \frac{B \cos\left(\frac{(kx-t\omega)\sqrt{4\mu-\lambda^2}}{2}\right) - A \sin\left(\frac{(kx-t\omega)\sqrt{4\mu-\lambda^2}}{2}\right)}{A \cos\left(\frac{(kx-t\omega)\sqrt{4\mu-\lambda^2}}{2}\right) + B \sin\left(\frac{(kx-t\omega)\sqrt{4\mu-\lambda^2}}{2}\right)} \right\}^2 \right]^2, \quad (4.2.43)$$

where $\omega = 4k^3\delta(\lambda^2 - 4\mu)$, A and B are arbitrary constants.

When $\lambda^2 - 4\mu = 0$,

$$u(x, t) = \left\{ \frac{15}{2}k^2\delta\lambda^2 - 30k^2\delta\mu - 30k^2\delta \left(\frac{B}{A + B(kx - t\omega)} \right)^2 \right\}^2, \quad (4.2.44)$$

where $\omega = 0$, A and B are arbitrary constants.

Since A and B are arbitrary constants, it may openhandedly pick their values. If $B = 0$ when $A \neq 0$, then the following solitary solutions from (4.2.42) and (4.2.43), respectively yield:

$$u_{2,13}(x, t) = \frac{225}{4} k^4 \delta^2 (\lambda^2 - 4\mu)^2 \operatorname{sech}^4 \left(\frac{1}{2} (kx - t\omega) \sqrt{\lambda^2 - 4\mu} \right), \quad (4.2.45)$$

$$u_{2,14}(x, t) = \frac{225}{4} k^4 \delta^2 (\lambda^2 - 4\mu)^2 \operatorname{sec}^4 \left(\frac{1}{2} (kx - t\omega) \sqrt{4\mu - \lambda^2} \right), \quad (4.2.46)$$

where $\omega = 4k^3\delta(\lambda^2 - 4\mu)$, k , δ , λ and μ are real parameters.

Again, if $A = 0$ when $B \neq 0$, then the following solitary solutions from (4.2.42) and (4.2.43) are extracted:

$$u_{2,15}(x, t) = \frac{225}{4} k^4 \delta^2 (\lambda^2 - 4\mu)^2 \operatorname{csch}^4 \left(\frac{1}{2} (kx - t\omega) \sqrt{\lambda^2 - 4\mu} \right), \quad (4.2.47)$$

$$u_{2,16}(x, t) = \frac{225}{4} k^4 \delta^2 (\lambda^2 - 4\mu)^2 \operatorname{csc}^4 \left(\frac{1}{2} (kx - t\omega) \sqrt{4\mu - \lambda^2} \right), \quad (4.2.48)$$

where $\omega = 4k^3\delta(\lambda^2 - 4\mu)$, k , δ , λ and μ are real parameters.

4.2(e): The Modified Kadomtsev-Petviashvili (KP) Equation for Acoustic Waves in Plasma Physics

Taha et al. (Taha et al., 2013) considered the modified KP equation for acoustic waves in plasma physics as follows:

$$\left(u_t + \alpha u^{1/2} u_x + \beta u_{x x x} \right)_x + \delta u_{y y} = 0, \quad (4.2.49)$$

where α, β and δ are arbitrary constants. They exploit the travelling wave variable

$$u(x, y, t) = v^2(x, y, t), \quad v(x, y, t) = U(\xi), \quad \xi = x + k y - \omega t, \quad (4.2.50)$$

and reduces the modified KP equation (4.2.49) to an ODE and integrating this ODE with respect to ξ , setting the integral constant to zero, they got a new ODE:

$$(\delta k^2 - \omega) U U' + \alpha U^2 U' + \beta (3 U' U'' + U U''') = 0. \quad (4.2.51)$$

Thus, Taha et al. evaluated the subsequent two sets of solutions to the ODE (4.2.51):

Case 1: When $D = \lambda^2 - 4\mu > 0$,

$$v(x, y, t) = -\frac{30\beta\mu}{\alpha} - \frac{30\beta\lambda}{\alpha} \left\{ -\frac{\lambda}{2} + \frac{\sqrt{D}}{2} \times \frac{B \cosh\left(\frac{\sqrt{D}}{2} \xi\right) + A \sinh\left(\frac{\sqrt{D}}{2} \xi\right)}{A \cosh\left(\frac{\sqrt{D}}{2} \xi\right) + B \sinh\left(\frac{\sqrt{D}}{2} \xi\right)} \right\} \\ - \frac{30\beta}{\alpha} \left\{ -\frac{\lambda}{2} + \frac{\sqrt{D}}{2} \times \frac{B \cosh\left(\frac{\sqrt{D}}{2} \xi\right) + A \sinh\left(\frac{\sqrt{D}}{2} \xi\right)}{A \cosh\left(\frac{\sqrt{D}}{2} \xi\right) + B \sinh\left(\frac{\sqrt{D}}{2} \xi\right)} \right\}^2. \quad (4.2.52)$$

When $D < 0$,

$$v(x, y, t) = -\frac{30\beta\mu}{\alpha} - \frac{30\beta\lambda}{\alpha} \left\{ -\frac{\lambda}{2} + \frac{\sqrt{D}}{2} \times \frac{B \cos\left(\frac{\sqrt{D}}{2} \xi\right) - A \sin\left(\frac{\sqrt{D}}{2} \xi\right)}{A \cos\left(\frac{\sqrt{D}}{2} \xi\right) + B \sin\left(\frac{\sqrt{D}}{2} \xi\right)} \right\} \\ - \frac{30\beta}{\alpha} \left\{ -\frac{\lambda}{2} + \frac{\sqrt{D}}{2} \times \frac{B \cos\left(\frac{\sqrt{D}}{2} \xi\right) - A \sin\left(\frac{\sqrt{D}}{2} \xi\right)}{A \cos\left(\frac{\sqrt{D}}{2} \xi\right) + B \sin\left(\frac{\sqrt{D}}{2} \xi\right)} \right\}^2. \quad (4.2.53)$$

When $D = 0$,

$$v(x, y, t) = -\frac{30\beta\mu}{\alpha} - \frac{30\beta\lambda}{\alpha} \left(\frac{B}{A + B\xi} - \frac{\lambda}{2} \right) - \frac{30\beta}{\alpha} \left(\frac{B}{A + B\xi} - \frac{\lambda}{2} \right)^2, \quad (4.2.54)$$

where $\xi = x + ky - t(k^2\delta + 4\beta\lambda^2 - 16\beta\mu)$, A and B are arbitrary constants.

Case 2: When $D > 0$,

$$v(x, y, t) = -\frac{5\beta(\lambda^2 + 2\mu)}{\alpha} - \frac{30\beta\lambda}{\alpha} \left\{ -\frac{\lambda}{2} + \frac{\sqrt{D}}{2} \times \frac{B \cosh\left(\frac{\sqrt{D}}{2} \xi\right) + A \sinh\left(\frac{\sqrt{D}}{2} \xi\right)}{A \cosh\left(\frac{\sqrt{D}}{2} \xi\right) + B \sinh\left(\frac{\sqrt{D}}{2} \xi\right)} \right\} \\ - \frac{30\beta}{\alpha} \left\{ -\frac{\lambda}{2} + \frac{\sqrt{D}}{2} \times \frac{B \cosh\left(\frac{\sqrt{D}}{2} \xi\right) + A \sinh\left(\frac{\sqrt{D}}{2} \xi\right)}{A \cosh\left(\frac{\sqrt{D}}{2} \xi\right) + B \sinh\left(\frac{\sqrt{D}}{2} \xi\right)} \right\}^2. \quad (4.2.55)$$

When $D < 0$,

$$v(x, y, t) = -\frac{5\beta(\lambda^2 + 2\mu)}{\alpha} - \frac{30\beta\lambda}{\alpha} \left\{ -\frac{\lambda}{2} + \frac{\sqrt{D}}{2} \times \frac{B \cos\left(\frac{\sqrt{D}}{2} \xi\right) - A \sin\left(\frac{\sqrt{D}}{2} \xi\right)}{A \cos\left(\frac{\sqrt{D}}{2} \xi\right) + B \sin\left(\frac{\sqrt{D}}{2} \xi\right)} \right\} \\ - \frac{30\beta}{\alpha} \left\{ -\frac{\lambda}{2} + \frac{\sqrt{D}}{2} \times \frac{B \cos\left(\frac{\sqrt{D}}{2} \xi\right) - A \sin\left(\frac{\sqrt{D}}{2} \xi\right)}{A \cos\left(\frac{\sqrt{D}}{2} \xi\right) + B \sin\left(\frac{\sqrt{D}}{2} \xi\right)} \right\}^2. \quad (4.2.56)$$

When $D = 0$,

$$v(x, y, t) = -\frac{5\beta(\lambda^2 + 2\mu)}{\alpha} - \frac{30\beta\lambda}{\alpha} \left(\frac{B}{A + B\xi} - \frac{\lambda}{2} \right) - \frac{30\beta}{\alpha} \left(\frac{B}{A + B\xi} - \frac{\lambda}{2} \right)^2, \quad (4.2.57)$$

where $\xi = x + ky - t(k^2\delta - 4\beta\lambda^2 + 16\beta\mu)$, A and B are arbitrary constants.

Since $u(x, y, t) = v^2(x, y, t)$ and Taha et al. constructed the solutions (4.2.52)-(4.2.57) to the ODE (4.2.51), hence it may be simplified the subsequent solutions to the modified KP equation (4.2.49):

Case 1: When $\lambda^2 - 4\mu > 0$,

$$u(x, y, t) = \left[\frac{\left(B \cosh\left(\frac{(x+ky-\omega t)\sqrt{\lambda^2-4\mu}}{2}\right) + A \sinh\left(\frac{(x+ky-\omega t)\sqrt{\lambda^2-4\mu}}{2}\right) \right)}{\left(A \cosh\left(\frac{(x+ky-\omega t)\sqrt{\lambda^2-4\mu}}{2}\right) + B \sinh\left(\frac{(x+ky-\omega t)\sqrt{\lambda^2-4\mu}}{2}\right) \right)} \right]^2 \\ \times \left[\frac{15\beta(4\mu - \lambda^2)}{2\alpha} + \frac{15\beta\lambda^2}{2\alpha} - \frac{30\beta\mu}{\alpha} \right], \quad (4.2.58)$$

where $\omega = k^2\delta + 4\beta\lambda^2 - 16\beta\mu$, A and B are arbitrary constants.

When $\lambda^2 - 4\mu < 0$,

$$u(x, y, t) = \left[-\frac{\left(B \cos\left(\frac{(x+ky-\omega t)\sqrt{4\mu-\lambda^2}}{2}\right) - A \sin\left(\frac{(x+ky-\omega t)\sqrt{4\mu-\lambda^2}}{2}\right) \right)}{\left(A \cos\left(\frac{(x+ky-\omega t)\sqrt{4\mu-\lambda^2}}{2}\right) + B \sin\left(\frac{(x+ky-\omega t)\sqrt{4\mu-\lambda^2}}{2}\right) \right)} \right]^2 \\ \times \left[\frac{15\beta(-\lambda^2 + 4\mu)}{2\alpha} + \frac{15\beta\lambda^2}{2\alpha} - \frac{30\beta\mu}{\alpha} \right], \quad (4.2.59)$$

where $\omega = k^2\delta + 4\beta\lambda^2 - 16\beta\mu$, A and B are arbitrary constants.

When $\lambda^2 - 4\mu = 0$,

$$u(x, y, t) = \left[\frac{15\beta\lambda^2}{2\alpha} - \frac{30\beta\mu}{\alpha} - \frac{30\beta}{\alpha} \times \left\{ \frac{B}{A + B(x + ky - \omega t)} \right\}^2 \right]^2, \quad (4.2.60)$$

where $\omega = k^2\delta$, A and B are arbitrary constants.

Case 2: When $\lambda^2 - 4\mu > 0$,

$$u(x, y, t) = \left[- \frac{\left(B \cosh \left(\frac{(x+ky-\omega t)\sqrt{\lambda^2-4\mu}}{2} \right) + A \sinh \left(\frac{(x+ky-\omega t)\sqrt{\lambda^2-4\mu}}{2} \right) \right)}{\left(A \cosh \left(\frac{(x+ky-\omega t)\sqrt{\lambda^2-4\mu}}{2} \right) + B \sinh \left(\frac{(x+ky-\omega t)\sqrt{\lambda^2-4\mu}}{2} \right) \right)} \right]^2 \\ \times \left[\frac{15\beta(\lambda^2 - 4\mu)}{2\alpha} + \frac{5\beta\lambda^2}{2\alpha} - \frac{10\beta\mu}{\alpha} \right]^2, \quad (4.2.61)$$

where $\omega = k^2\delta - 4\beta\lambda^2 + 16\beta\mu$, A and B are arbitrary constants.

When $\lambda^2 - 4\mu < 0$,

$$u(x, y, t) = \left[- \frac{\left(B \cos \left(\frac{(x+ky-\omega t)\sqrt{4\mu-\lambda^2}}{2} \right) - A \sin \left(\frac{(x+ky-\omega t)\sqrt{4\mu-\lambda^2}}{2} \right) \right)}{\left(A \cos \left(\frac{(x+ky-\omega t)\sqrt{4\mu-\lambda^2}}{2} \right) + B \sin \left(\frac{(x+ky-\omega t)\sqrt{4\mu-\lambda^2}}{2} \right) \right)} \right]^2 \\ \times \left[\frac{15\beta(4\mu - \lambda^2)}{2\alpha} + \frac{5\beta\lambda^2}{2\alpha} - \frac{10\beta\mu}{\alpha} \right]^2, \quad (4.2.62)$$

where $\omega = k^2\delta - 4\beta\lambda^2 + 16\beta\mu$, A and B are arbitrary constants.

When $\lambda^2 - 4\mu = 0$,

$$u(x, y, t) = \left[\frac{5\beta\lambda^2}{2\alpha} - \frac{10\beta\mu}{\alpha} - \frac{30\beta}{\alpha} \times \left\{ \frac{B}{A + B(x + ky - \omega t)} \right\}^2 \right]^2, \quad (4.2.63)$$

where $\omega = k^2\delta$, A and B are arbitrary constants.

If $B = 0$ when $A \neq 0$, then the following solitary solutions from (4.2.58), (4.2.59), (4.2.61) and (4.2.62), respectively yield:

$$u_{2,17}(x, y, t) = \frac{225\beta^2(\lambda^2 - 4\mu)^2}{4\alpha^2} \operatorname{sech}^4 \left(\frac{(x + ky - \omega t)\sqrt{\lambda^2 - 4\mu}}{2} \right), \quad (4.2.64)$$

$$u_{2,18}(x, y, t) = \frac{225\beta^2(\lambda^2 - 4\mu)^2}{4\alpha^2} \operatorname{sec}^4 \left(\frac{(x + ky - \omega t)\sqrt{4\mu - \lambda^2}}{2} \right), \quad (4.2.65)$$

$$u_{2,19}(x, y, t) = \frac{25\beta^2(\lambda^2 - 4\mu)^2 \left(1 - 3 \tanh^2 \left(\frac{(x+ky-\omega t)\sqrt{\lambda^2-4\mu}}{2} \right) \right)^2}{4\alpha^2}, \quad (4.2.66)$$

$$u_{2,20}(x, y, t) = \frac{25\beta^2(\lambda^2 - 4\mu)^2 \left(1 + 3 \tan^2 \left(\frac{(x+ky-\omega t)\sqrt{4\mu-\lambda^2}}{2} \right) \right)^2}{4\alpha^2}, \quad (4.2.67)$$

where $\omega = k^2\delta + 4\beta\lambda^2 - 16\beta\mu$ and α, β, λ and μ are real parameters.

Again, if $A = 0$ when $B \neq 0$, then the subsequent solitary solutions from (4.2.58), (4.2.59), (4.2.61) and (4.2.62), respectively yield:

$$u_{2,21}(x, y, t) = \frac{225\beta^2(\lambda^2 - 4\mu)^2}{4\alpha^2} \operatorname{csch}^4 \left(\frac{(x + ky - \omega t)\sqrt{\lambda^2 - 4\mu}}{2} \right), \quad (4.2.68)$$

$$u_{2,22}(x, y, t) = \frac{225\beta^2(\lambda^2 - 4\mu)^2}{4\alpha^2} \operatorname{csc}^4 \left(\frac{(x + ky - \omega t)\sqrt{4\mu - \lambda^2}}{2} \right), \quad (4.2.69)$$

$$u_{2,23}(x, y, t) = \frac{25\beta^2(\lambda^2 - 4\mu)^2 \left(2 + 3 \operatorname{csch}^2 \left(\frac{(x+ky-\omega t)\sqrt{\lambda^2-4\mu}}{2} \right) \right)^2}{4\alpha^2}, \quad (4.2.70)$$

$$u_{2,24}(x, y, t) = \frac{25\beta^2(\lambda^2 - 4\mu)^2 \left(-2 + 3 \operatorname{csc}^2 \left(\frac{(x+ky-\omega t)\sqrt{4\mu-\lambda^2}}{2} \right) \right)^2}{4\alpha^2}, \quad (4.2.71)$$

where $\omega = k^2\delta - 4\beta\lambda^2 + 16\beta\mu$ and α, β, λ and μ are real parameters.

4.2(f): The Strain Wave Equation in Microstructured Solids

Khan and Akbar (Khan and Akbar, 2015c) considered the strain wave equation in microstructured solids as follows:

$$u_{tt} - u_{xx} - \varepsilon \alpha_1 (u^2)_{xx} - \gamma \alpha_2 u_{xxt} + \delta \alpha_3 u_{xxxx} - (\delta \alpha_4 - \gamma^2 \alpha_7) u_{xxtt} + \gamma \delta (\alpha_5 u_{xxxxt} + \alpha_6 u_{xxtt}) = 0. \quad (4.2.72)$$

They discussed both the non-dissipative and dissipative cases.

4.2(f)-I: The Non-dissipative Case

If $\gamma = 0$, then the Eq. (4.2.72) is non-dissipative and it is governed by the double dispersive equation:

$$u_{tt} - u_{xx} - \varepsilon \{ \alpha_1 (u^2)_{xx} - \alpha_3 u_{xxxx} + \alpha_4 u_{xxtt} \} = 0. \quad (4.2.73)$$

By a proper manipulation there arise a set of algebraic equations and solving these algebraic equations, the following values of a_0 , a_1 , a_2 and ω are found:

Set 1:

$$a_0 = \frac{(\lambda^2 + 2\mu)(\alpha_3 - \alpha_4)}{\alpha_1 \{1 + \varepsilon(\lambda^2 - 4\mu)\alpha_4\}}, \quad a_1 = \frac{6\lambda(\alpha_3 - \alpha_4)}{\alpha_1 \{1 + \varepsilon(\lambda^2 - 4\mu)\alpha_4\}},$$

$$a_2 = \frac{6(\alpha_3 - \alpha_4)}{\alpha_1 \{1 + \varepsilon(\lambda^2 - 4\mu)\alpha_4\}}, \quad \omega = \pm \frac{\sqrt{1 + \varepsilon\lambda^2\alpha_3 - 4\varepsilon\mu\alpha_3}}{\sqrt{1 + \varepsilon\lambda^2\alpha_4 - 4\varepsilon\mu\alpha_4}}$$

Set 2:

$$a_0 = \frac{6\mu(-\alpha_3 + \alpha_4)}{\alpha_1 \{-1 + \varepsilon(\lambda^2 - 4\mu)\alpha_4\}}, \quad a_1 = -\frac{6\lambda(\alpha_3 - \alpha_4)}{\alpha_1 \{-1 + \varepsilon(\lambda^2 - 4\mu)\alpha_4\}},$$

$$a_2 = -\frac{6(\alpha_3 - \alpha_4)}{\alpha_1 \{-1 + \varepsilon(\lambda^2 - 4\mu)\alpha_4\}}, \quad \omega = \pm \frac{\sqrt{-1 + \varepsilon\lambda^2\alpha_3 - 4\varepsilon\mu\alpha_3}}{\sqrt{-1 + \varepsilon\lambda^2\alpha_4 - 4\varepsilon\mu\alpha_4}}$$

when $a_2 \neq 0$.

Therefore, for Set 1, the solution (4.2.1) becomes

$$U(\xi) = \frac{(\lambda^2 + 2\mu)(\alpha_3 - \alpha_4)}{\alpha_1(1 + \varepsilon(\lambda^2 - 4\mu)\alpha_4)} + \frac{6(\alpha_3 - \omega^2\alpha_4)}{\alpha_1} \left\{ \lambda \left(\frac{G'}{G} \right) + \left(\frac{G'}{G} \right)^2 \right\}. \quad (4.2.74)$$

Hence, they obtained the subsequent solutions:

Family 1: When $\lambda^2 - 4\mu > 0$,

$$u(x, t) = -\frac{(\lambda^2 - 4\mu)(\alpha_3 - \alpha_4)}{2\alpha_1(1 + \varepsilon(\lambda^2 - 4\mu)\alpha_4)} + \frac{3(\lambda^2 - 4\mu)(\alpha_3 - \alpha_4)}{2\alpha_1(1 + \varepsilon(\lambda^2 - 4\mu)\alpha_4)} \\ \times \left\{ \frac{B \cosh\left(\frac{(x-\omega t)\sqrt{\lambda^2-4\mu}}{2}\right) + A \sinh\left(\frac{(x-\omega t)\sqrt{\lambda^2-4\mu}}{2}\right)}{A \cosh\left(\frac{(x-\omega t)\sqrt{\lambda^2-4\mu}}{2}\right) + B \sinh\left(\frac{(x-\omega t)\sqrt{\lambda^2-4\mu}}{2}\right)} \right\}^2, \quad (4.2.75)$$

where $\omega = \pm \frac{\sqrt{1+\varepsilon\lambda^2\alpha_3-4\varepsilon\mu\alpha_3}}{\sqrt{1+\varepsilon\lambda^2\alpha_4-4\varepsilon\mu\alpha_4}}$, A and B are arbitrary constants.

Family 2: When $\lambda^2 - 4\mu < 0$,

$$u(x, t) = -\frac{(\lambda^2 - 4\mu)(\alpha_3 - \alpha_4)}{2\alpha_1(1 + \varepsilon(\lambda^2 - 4\mu)\alpha_4)} - \frac{3(\lambda^2 - 4\mu)(\alpha_3 - \alpha_4)}{2\alpha_1(1 + \varepsilon(\lambda^2 - 4\mu)\alpha_4)} \\ \times \left\{ \frac{B \cos\left(\frac{(x-\omega t)\sqrt{4\mu-\lambda^2}}{2}\right) - A \sin\left(\frac{(x-\omega t)\sqrt{4\mu-\lambda^2}}{2}\right)}{A \cos\left(\frac{(x-\omega t)\sqrt{4\mu-\lambda^2}}{2}\right) + B \sin\left(\frac{(x-\omega t)\sqrt{4\mu-\lambda^2}}{2}\right)} \right\}^2, \quad (4.2.76)$$

where $\omega = \pm \frac{\sqrt{1+\varepsilon\lambda^2\alpha_3-4\varepsilon\mu\alpha_3}}{\sqrt{1+\varepsilon\lambda^2\alpha_4-4\varepsilon\mu\alpha_4}}$, A and B are arbitrary constants.

Family 3: When $\lambda^2 - 4\mu = 0$,

$$u(x, t) = \frac{6(\alpha_3 - \alpha_4)}{\alpha_1(1 + \varepsilon(\lambda^2 - 4\mu)\alpha_4)} \left\{ \frac{B}{A + B(x - \omega t)} \right\}^2 \\ - \frac{(\lambda^2 - 4\mu)(\alpha_3 - \alpha_4)}{2\alpha_1(1 + \varepsilon(\lambda^2 - 4\mu)\alpha_4)}, \quad (4.2.77)$$

where $\omega = \pm 1$, A and B are arbitrary constants.

Again for Set 2, the solution (4.2.1) becomes

$$U(\xi) = \frac{6\mu(-\alpha_3 + \alpha_4)}{\alpha_1\{-1 + \varepsilon(\lambda^2 - 4\mu)\alpha_4\}} \\ - \frac{6(\alpha_3 - \alpha_4)}{\alpha_1\{-1 + \varepsilon(\lambda^2 - 4\mu)\alpha_4\}} \left\{ \lambda \left(\frac{G'}{G} \right) + \left(\frac{G'}{G} \right)^2 \right\}. \quad (4.2.78)$$

Therefore, they obtained the following solutions:

Family 1: When $\lambda^2 - 4\mu > 0$,

$$u(x, t) = \frac{3(\lambda^2 - 4\mu)(\alpha_3 - \alpha_4)}{2\alpha_1\{-1 + \varepsilon(\lambda^2 - 4\mu)\alpha_4\}} + \frac{(\lambda^2 - 4\mu)(-6\alpha_3 + 6\alpha_4)}{4\alpha_1\{-1 + \varepsilon(\lambda^2 - 4\mu)\alpha_4\}} \\ \times \left\{ \frac{B \cosh\left(\frac{(x-\omega t)\sqrt{\lambda^2-4\mu}}{2}\right) + A \sinh\left(\frac{(x-\omega t)\sqrt{\lambda^2-4\mu}}{2}\right)}{A \cosh\left(\frac{(x-\omega t)\sqrt{\lambda^2-4\mu}}{2}\right) + B \sinh\left(\frac{(x-\omega t)\sqrt{\lambda^2-4\mu}}{2}\right)} \right\}^2, \quad (4.2.79)$$

where $\omega = \pm \frac{\sqrt{-1+\varepsilon\lambda^2\alpha_3-4\varepsilon\mu\alpha_3}}{\sqrt{-1+\varepsilon\lambda^2\alpha_4-4\varepsilon\mu\alpha_4}}$, A and B are arbitrary constants.

Family 2: When $\lambda^2 - 4\mu < 0$,

$$u(x, t) = \frac{3(\lambda^2 - 4\mu)(\alpha_3 - \alpha_4)}{2\alpha_1\{-1 + \varepsilon(\lambda^2 - 4\mu)\alpha_4\}} + \frac{3(\lambda^2 - 4\mu)(\alpha_3 - \alpha_4)}{2\alpha_1\{-1 + \varepsilon(\lambda^2 - 4\mu)\alpha_4\}} \\ \times \left\{ \frac{B \cos\left(\frac{(x-\omega t)\sqrt{4\mu-\lambda^2}}{2}\right) - A \sin\left(\frac{(x-\omega t)\sqrt{4\mu-\lambda^2}}{2}\right)}{A \cos\left(\frac{(x-\omega t)\sqrt{4\mu-\lambda^2}}{2}\right) + B \sin\left(\frac{(x-\omega t)\sqrt{4\mu-\lambda^2}}{2}\right)} \right\}^2, \quad (4.2.80)$$

where $\omega = \pm \frac{\sqrt{-1+\varepsilon\lambda^2\alpha_3-4\varepsilon\mu\alpha_3}}{\sqrt{-1+\varepsilon\lambda^2\alpha_4-4\varepsilon\mu\alpha_4}}$, A and B are arbitrary constants.

Family 3: When $\lambda^2 - 4\mu = 0$,

$$u(x, t) = -\frac{6(\alpha_3 - \alpha_4)}{\alpha_1(-1 + \varepsilon\lambda^2\alpha_4 - 4\varepsilon\mu\alpha_4)} \left\{ \frac{B}{A + B(x - \omega t)} \right\}^2 \\ + \frac{3(\lambda^2 - 4\mu)(\alpha_3 - \alpha_4)}{2\alpha_1\{-1 + \varepsilon(\lambda^2 - 4\mu)\alpha_4\}}, \quad (4.2.81)$$

where $\omega = \pm 1$, A and B are arbitrary constants.

If $B = 0$ when $A \neq 0$, then the following solitary solutions from (4.2.75), (4.2.76), (4.2.79) and (4.2.80), respectively yield:

$$u_{2,25}(x, t) = \frac{(\lambda^2 - 4\mu)(\alpha_3 - \alpha_4) \left\{ -1 + 3 \tanh^2\left(\frac{(x-\omega t)\sqrt{\lambda^2-4\mu}}{2}\right) \right\}}{2\alpha_1\{1 + \varepsilon(\lambda^2 - 4\mu)\alpha_4\}}, \quad (4.2.82)$$

$$u_{2,26}(x, t) = -\frac{(\lambda^2 - 4\mu)(\alpha_3 - \alpha_4) \left\{ 1 + 3 \tan^2 \left(\frac{(x-\omega t)\sqrt{4\mu-\lambda^2}}{2} \right) \right\}}{2\alpha_1 \{1 + \varepsilon(\lambda^2 - 4\mu)\alpha_4\}}, \quad (4.2.83)$$

where $\omega = \pm \frac{\sqrt{1+\varepsilon\lambda^2\alpha_3-4\varepsilon\mu\alpha_3}}{\sqrt{1+\varepsilon\lambda^2\alpha_4-4\varepsilon\mu\alpha_4}}$, $\alpha_1, \alpha_3, \alpha_4, \varepsilon, \lambda$ and μ are real parameters.

$$u_{2,27}(x, t) = \frac{3(\lambda^2 - 4\mu)(\alpha_3 - \alpha_4) \operatorname{sech}^2 \left(\frac{(x-\omega t)\sqrt{\lambda^2-4\mu}}{2} \right)}{2\alpha_1 \{-1 + \varepsilon(\lambda^2 - 4\mu)\alpha_4\}}, \quad (4.2.84)$$

$$u_{2,28}(x, t) = \frac{3(\lambda^2 - 4\mu)(\alpha_3 - \alpha_4) \operatorname{sec}^2 \left(\frac{(x-\omega t)\sqrt{4\mu-\lambda^2}}{2} \right)}{2\alpha_1 \{-1 + \varepsilon(\lambda^2 - 4\mu)\alpha_4\}}, \quad (4.2.85)$$

where $\omega = \pm \frac{\sqrt{-1+\varepsilon\lambda^2\alpha_3-4\varepsilon\mu\alpha_3}}{\sqrt{-1+\varepsilon\lambda^2\alpha_4-4\varepsilon\mu\alpha_4}}$, $\alpha_1, \alpha_3, \alpha_4, \varepsilon, \lambda$ and μ are real parameters.

Again, if $A = 0$ when $B \neq 0$, then the following solitary solutions from (4.2.75), (4.2.76), (4.2.79) and (4.2.80), respectively yield:

$$u_{2,29}(x, t) = \frac{(\lambda^2 - 4\mu) \left(-1 + 3 \coth^2 \left(\frac{(x-\omega t)\sqrt{\lambda^2-4\mu}}{2} \right) \right) (\alpha_3 - \alpha_4)}{2\alpha_1 (1 + \varepsilon(\lambda^2 - 4\mu)\alpha_4)}, \quad (4.2.86)$$

$$u_{2,30}(x, t) = -\frac{(\lambda^2 - 4\mu) \left(1 + 3 \cot^2 \left(\frac{(x-\omega t)\sqrt{4\mu-\lambda^2}}{2} \right) \right) (\alpha_3 - \alpha_4)}{2\alpha_1 (1 + \varepsilon(\lambda^2 - 4\mu)\alpha_4)}, \quad (4.2.87)$$

where $\omega = \pm \frac{\sqrt{1+\varepsilon\lambda^2\alpha_3-4\varepsilon\mu\alpha_3}}{\sqrt{1+\varepsilon\lambda^2\alpha_4-4\varepsilon\mu\alpha_4}}$, $\alpha_1, \alpha_3, \alpha_4, \varepsilon, \lambda$ and μ are real parameters.

$$u_{2,31}(x, t) = -\frac{3(\lambda^2 - 4\mu)(\alpha_3 - \alpha_4) \operatorname{csch}^2 \left(\frac{(x-\omega t)\sqrt{\lambda^2-4\mu}}{2} \right)}{2\alpha_1 \{-1 + \varepsilon(\lambda^2 - 4\mu)\alpha_4\}}, \quad (4.2.88)$$

$$u_{2,32}(x, t) = \frac{3(\lambda^2 - 4\mu)(\alpha_3 - \alpha_4) \operatorname{csc}^2 \left(\frac{(x-\omega t)\sqrt{4\mu-\lambda^2}}{2} \right)}{2\alpha_1 \{-1 + \varepsilon(\lambda^2 - 4\mu)\alpha_4\}}, \quad (4.2.89)$$

where $\omega = \pm \frac{\sqrt{-1+\varepsilon\lambda^2\alpha_3-4\varepsilon\mu\alpha_3}}{\sqrt{-1+\varepsilon\lambda^2\alpha_4-4\varepsilon\mu\alpha_4}}$, $\alpha_1, \alpha_3, \alpha_4, \varepsilon, \lambda$ and μ are real parameters.

4.2(f)-II: The Dissipative Case

If $\gamma \neq 0$, then the Eq. (4.2.72) is dissipative and it is governed by the double dispersive equation, when $\delta = \gamma = O(\varepsilon)$ and $\varepsilon \rightarrow 0$, the equation can be written as:

$$u_{tt} - u_{xx} - \varepsilon \{ \alpha_1 (u^2)_{xx} + \alpha_2 u_{xxt} - \alpha_3 u_{xxxx} + \alpha_4 u_{xxtt} \} = 0. \quad (4.2.90)$$

By a proper manipulation there arise a set of algebraic equation and solving these algebraic equations, the following values are found:

$$\begin{aligned} a_0 &= \frac{1}{50\varepsilon\alpha_1(\alpha_3 - \omega^2\alpha_4)} [-\varepsilon\omega^2\alpha_2^2 + 30\varepsilon\lambda\omega\alpha_2(-\alpha_3 + \omega^2\alpha_4) \\ &\quad + 25(\alpha_3 - \omega^2\alpha_4)\{-1 + \omega^2 + \varepsilon(\lambda^2 + 8\mu)(\alpha_3 - \omega^2\alpha_4)\}], \\ a_1 &= -\frac{6\{\omega\alpha_2 - 5\lambda(\alpha_3 - \omega^2\alpha_4)\}}{5\alpha_1}, \\ a_2 &= \frac{6(\alpha_3 - \omega^2\alpha_4)}{\alpha_1}, \\ h &= [\varepsilon^2\omega^4\alpha_2^4 + 60\varepsilon^2\lambda\omega^3\alpha_2^3(\alpha_3 - \omega^2\alpha_4) + 850\varepsilon^2(\lambda^2 - 4\mu)\omega^2\alpha_2^2(\alpha_3 - \omega^2\alpha_4)^2 \\ &\quad + 1500\varepsilon^2\lambda(\lambda^2 - 4\mu)\omega\alpha_2(-\alpha_3 + \omega^2\alpha_4)^3 \\ &\quad + 625(\alpha_3 - \omega^2\alpha_4)^2\{-(-1 + \omega^2)^2 + \varepsilon^2(\lambda^2 - 4\mu)^2(\alpha_3 - \omega^2\alpha_4)^2\}] \\ &\quad / \{2500\varepsilon\alpha_1(\alpha_3 - \omega^2\alpha_4)^2\}, \end{aligned}$$

where

$$\omega = \begin{cases} \frac{\pm 1}{5\sqrt{2}} \sqrt{\frac{\alpha_2^2 + 50(\lambda^2 - 4\mu)\alpha_3\alpha_4 - \alpha_2\sqrt{\alpha_2^2 + 100(\lambda^2 - 4\mu)\alpha_3\alpha_4}}{(\lambda^2 - 4\mu)\alpha_4^2}} = \pm\rho_1(\text{say}) \\ \frac{\pm 1}{5\sqrt{2}} \sqrt{\frac{\alpha_2^2 + 50(\lambda^2 - 4\mu)\alpha_3\alpha_4 + \alpha_2\sqrt{\alpha_2^2 + 100(\lambda^2 - 4\mu)\alpha_3\alpha_4}}{(\lambda^2 - 4\mu)\alpha_4^2}} = \pm\rho_2(\text{say}). \end{cases}$$

Therefore, the solution (4.2.1) becomes:

$$\begin{aligned} U(\xi) &= \frac{6(\alpha_3 - \omega^2\alpha_4)}{\alpha_1} \left(\frac{G'}{G}\right)^2 - \frac{6\{\omega\alpha_2 - 5\lambda(\alpha_3 - \omega^2\alpha_4)\}}{5\alpha_1} \left(\frac{G'}{G}\right) \\ &\quad + \frac{1}{50\varepsilon\alpha_1(\alpha_3 - \omega^2\alpha_4)} [-\varepsilon\omega^2\alpha_2^2 + 30\varepsilon\lambda\omega\alpha_2(-\alpha_3 + \omega^2\alpha_4) \\ &\quad + 25(\alpha_3 - \omega^2\alpha_4)\{-1 + \omega^2 + \varepsilon(\lambda^2 + 8\mu)(\alpha_3 - \omega^2\alpha_4)\}], \quad (4.2.91) \end{aligned}$$

where $\omega = \pm\rho_1$ or $\pm\rho_2$.

Hence, they obtained the following solutions:

Set 1: When $\lambda^2 - 4\mu > 0$,

$$\begin{aligned}
u(x, t) = & -\frac{\varepsilon\omega^2\alpha_2^2 + 25(\alpha_3 - \omega^2\alpha_4)\{1 - \omega^2 + 2\varepsilon(\lambda^2 - 4\mu)(\alpha_3 - \omega^2\alpha_4)\}}{50\varepsilon\alpha_1(\alpha_3 - \omega^2\alpha_4)} \\
& - \left\{ \frac{B\cosh\left(\frac{(x-\omega t)\sqrt{\lambda^2-4\mu}}{2}\right) + A\sinh\left(\frac{(x-\omega t)\sqrt{\lambda^2-4\mu}}{2}\right)}{A\cosh\left(\frac{(x-\omega t)\sqrt{\lambda^2-4\mu}}{2}\right) + B\sinh\left(\frac{(x-\omega t)\sqrt{\lambda^2-4\mu}}{2}\right)} \right\} \\
& \times \frac{3\omega\alpha_2\sqrt{\lambda^2 - 4\mu}}{5\alpha_1} + \frac{3(\lambda^2 - 4\mu)(\alpha_3 - \omega^2\alpha_4)}{2\alpha_1} \\
& \times \left\{ \frac{B\cosh\left(\frac{(x-\omega t)\sqrt{\lambda^2-4\mu}}{2}\right) + A\sinh\left(\frac{(x-\omega t)\sqrt{\lambda^2-4\mu}}{2}\right)}{A\cosh\left(\frac{(x-\omega t)\sqrt{\lambda^2-4\mu}}{2}\right) + B\sinh\left(\frac{(x-\omega t)\sqrt{\lambda^2-4\mu}}{2}\right)} \right\}^2, \quad (4.2.92)
\end{aligned}$$

where $\omega = \pm\rho_1$ or $\pm\rho_2$, A and B are arbitrary constants.

Set 2: When $\lambda^2 - 4\mu < 0$,

$$\begin{aligned}
u(x, t) = & -\frac{\varepsilon\omega^2\alpha_2^2 + 25(\alpha_3 - \omega^2\alpha_4)\{1 - \omega^2 + 2\varepsilon(\lambda^2 - 4\mu)(\alpha_3 - \omega^2\alpha_4)\}}{50\varepsilon\alpha_1(\alpha_3 - \omega^2\alpha_4)} \\
& - \frac{3\omega\alpha_2\sqrt{4\mu - \lambda^2}}{5\alpha_1} \times \left\{ \frac{B\cos\left(\frac{(x-\omega t)\sqrt{4\mu-\lambda^2}}{2}\right) - A\sin\left(\frac{(x-\omega t)\sqrt{4\mu-\lambda^2}}{2}\right)}{A\cos\left(\frac{(x-\omega t)\sqrt{4\mu-\lambda^2}}{2}\right) + B\sin\left(\frac{(x-\omega t)\sqrt{4\mu-\lambda^2}}{2}\right)} \right\} \\
& + \frac{3(4\mu - \lambda^2)(\alpha_3 - \omega^2\alpha_4)}{2\alpha_1} \\
& \times \left\{ \frac{B\cos\left(\frac{(x-\omega t)\sqrt{4\mu-\lambda^2}}{2}\right) - A\sin\left(\frac{(x-\omega t)\sqrt{4\mu-\lambda^2}}{2}\right)}{A\cos\left(\frac{(x-\omega t)\sqrt{4\mu-\lambda^2}}{2}\right) + B\sin\left(\frac{(x-\omega t)\sqrt{4\mu-\lambda^2}}{2}\right)} \right\}^2, \quad (4.2.93)
\end{aligned}$$

where $\omega = \pm\rho_1$ or $\pm\rho_2$, A and B are arbitrary constants.

Set 3: When $\lambda^2 - 4\mu = 0$,

$$\begin{aligned}
u(x, t) = & -\frac{\varepsilon\omega^2\alpha_2^2 + 25(\alpha_3 - \omega^2\alpha_4)\{1 - \omega^2 + 2\varepsilon(\lambda^2 - 4\mu)(\alpha_3 - \omega^2\alpha_4)\}}{50\varepsilon\alpha_1(\alpha_3 - \omega^2\alpha_4)} \\
& -\frac{6\omega\alpha_2}{5\alpha_1} \times \left\{ \frac{B}{A + B(x - \omega t)} \right\} + \frac{6(\alpha_3 - \omega^2\alpha_4)}{\alpha_1} \\
& \times \left\{ \frac{B}{A + B(x - \omega t)} \right\}^2, \tag{4.2.94}
\end{aligned}$$

where $\omega = \pm\rho_1$ or $\pm\rho_2$, A and B are arbitrary constants.

If $B = 0$ when $A \neq 0$, then the following solitary solutions from (4.2.92) and (4.2.93), respectively yield:

$$\begin{aligned}
u_{2,33}(x, t) = & -\frac{\varepsilon\omega^2\alpha_2^2 + 25(\alpha_3 - \omega^2\alpha_4)\{1 - \omega^2 + 2\varepsilon(\lambda^2 - 4\mu)(\alpha_3 - \omega^2\alpha_4)\}}{50\varepsilon\alpha_1(\alpha_3 - \omega^2\alpha_4)} \\
& -\frac{3}{10\alpha_1} \tanh\left(\frac{(x - \omega t)\sqrt{\lambda^2 - 4\mu}}{2}\right) \left\{ 2\sqrt{\lambda^2 - 4\mu} \omega\alpha_2 \right. \\
& \left. - 5(\lambda^2 - 4\mu)(\alpha_3 - \omega^2\alpha_4) \tanh\left(\frac{(x - \omega t)\sqrt{\lambda^2 - 4\mu}}{2}\right) \right\}, \tag{4.2.95}
\end{aligned}$$

$$\begin{aligned}
u_{2,34}(x, t) = & -\frac{\varepsilon\omega^2\alpha_2^2 + 25(\alpha_3 - \omega^2\alpha_4)\{1 - \omega^2 + 2\varepsilon(\lambda^2 - 4\mu)(\alpha_3 - \omega^2\alpha_4)\}}{50\varepsilon\alpha_1(\alpha_3 - \omega^2\alpha_4)} \\
& +\frac{3}{10\alpha_1} \tan\left(\frac{(x - \omega t)\sqrt{4\mu - \lambda^2}}{2}\right) \left\{ 2\sqrt{-\lambda^2 + 4\mu} \omega\alpha_2 \right. \\
& \left. - 5(\lambda^2 - 4\mu)(\alpha_3 - \omega^2\alpha_4) \times \tan\left(\frac{(x - \omega t)\sqrt{4\mu - \lambda^2}}{2}\right) \right\}, \tag{4.2.96}
\end{aligned}$$

where $\omega = \pm\rho_1$ or $\pm\rho_2$, $\varepsilon, \lambda, \mu, \alpha_1, \alpha_2, \alpha_3$ and α_4 are real parameters.

Also, if $B = 0$ when $A \neq 0$, then the following solitary solutions from (4.2.92) and (4.2.93), respectively yield:

$$\begin{aligned}
u_{2,35}(x, t) = & -\frac{\varepsilon\omega^2\alpha_2^2 + 25(\alpha_3 - \omega^2\alpha_4)\{1 - \omega^2 + 2\varepsilon(\lambda^2 - 4\mu)(\alpha_3 - \omega^2\alpha_4)\}}{50\varepsilon\alpha_1(\alpha_3 - \omega^2\alpha_4)} \\
& - \frac{3}{10\alpha_1} \left\{ 2\sqrt{\lambda^2 - 4\mu} \omega\alpha_2 - 5(\lambda^2 - 4\mu)(\alpha_3 - \omega^2\alpha_4) \right. \\
& \times \coth\left(\frac{(x - \omega t)\sqrt{\lambda^2 - 4\mu}}{2}\right) \left. \right\} \coth\left(\frac{(x - \omega t)\sqrt{\lambda^2 - 4\mu}}{2}\right), \quad (4.2.97)
\end{aligned}$$

$$\begin{aligned}
u_{2,36}(x, t) = & -\frac{\varepsilon\omega^2\alpha_2^2 + 25(\alpha_3 - \omega^2\alpha_4)\{1 - \omega^2 + 2\varepsilon(\lambda^2 - 4\mu)(\alpha_3 - \omega^2\alpha_4)\}}{50\varepsilon\alpha_1(\alpha_3 - \omega^2\alpha_4)} \\
& - \frac{3}{10\alpha_1} (\alpha_3 - \omega^2\alpha_4) \left\{ 2\sqrt{-\lambda^2 + 4\mu} \omega\alpha_2 + 5(\lambda^2 - 4\mu) \right. \\
& \times \cot\left(\frac{(x - \omega t)\sqrt{4\mu - \lambda^2}}{2}\right) \left. \right\} \cot\left(\frac{(x - \omega t)\sqrt{4\mu - \lambda^2}}{2}\right), \quad (4.2.98)
\end{aligned}$$

where $\omega = \pm\rho_1$ or $\pm\rho_2$, $\varepsilon, \lambda, \mu, \alpha_1, \alpha_2, \alpha_3$ and α_4 are real parameters.

Chapter 5

The Graphical Representations and Physical Explanations

Preview Material

➤ 5.1: The Graphical Representations

- ✚ 5.1(a): The KdV Equation
- ✚ 5.1(b): The Boussinesq Equation
- ✚ 5.1(c): The Fifth-order KdV Equation
- ✚ 5.1(d): The Modified Schamel Equation for Acoustic Waves in Plasma Physics
- ✚ 5.1(e): The Modified Kadomtsev-Petviashvili (KP) Equation for Acoustic Waves in Plasma Physics
- ✚ 5.1(f): The Strain Wave Equation in Microstructured Solids
 - 5.1(f)-I: The Non-dissipative Case
 - 5.1(f)-II: The Dissipative Case

➤ 5.2: The Physical Explanations

- ✚ 5.2(a): The KdV Equation
- ✚ 5.2(b): The Boussinesq Equation
- ✚ 5.2(c): The Fifth-order KdV Equation
- ✚ 5.2(d): The Modified Schamel Equation for Acoustic Waves in Plasma Physics
- ✚ 5.2(e): The Modified Kadomtsev-Petviashvili (KP) Equation for Acoustic Waves in Plasma Physics
- ✚ 5.2(f): The Strain Wave Equation in Microstructured Solids
 - 5.2(f)-I: The Non-dissipative Case
 - 5.2(f)-II: The Dissipative Case

In this Chapter, we have interpreted the nature and physical significance of the traveling wave solution to the NLEEs found in Chapter 4 by means of the graphical representation.

5.1: The Graphical Representations

By means of graphical representation one can explain the physical structure of the problems born in our real life. The basic knowledge of graph is very easy and it is a powerful mathematical tool because it shows the relation of any two or more materials used in our daily life. Mathematically, a graph represents the diagram to any solution of problems and it describes clearly the character of analytical or numerical or close-form solutions or any information to repeatedly use for proportional reason. Also it needs construction of the basic acquaintance of a graph signified, when doing computation in daily life. Therefore, we have drawn some graphs of the obtained solutions to the NLEEs examined in Chapter 4 through the MSE method.

5.1(a): The KdV Equation

We have drawn some graphs of the obtained traveling wave solutions to the KdV equation via the MSE method and represented in the subsequent figures 1-8 with the aid of symbolic computation software, such as Mathematica:

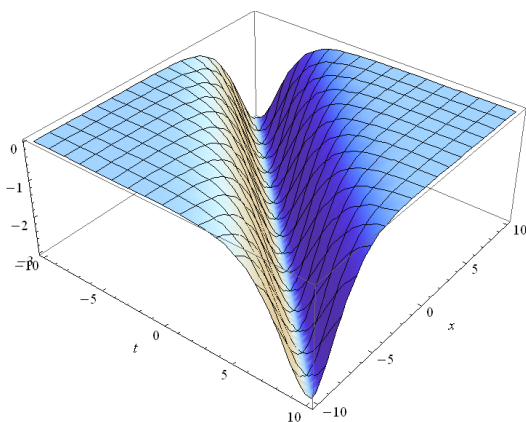

Figure 1: Sketch of the anti-bell shape soliton $u_{1,1}$ in (4.1.17) to the KdV equation for $\delta = -2$, $\omega = -1$ within $-10 \leq x, t \leq 10$.

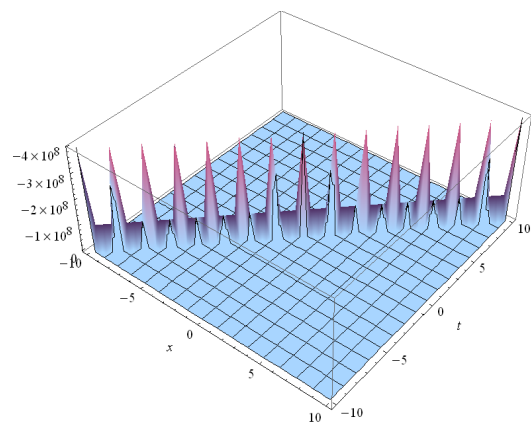

Figure 2: Sketch of the singular multi-soliton $u_{1,2}$ in (4.1.18) to the KdV equation for $\delta = 1$, $\omega = 1$ within $-10 \leq x, t \leq 10$.

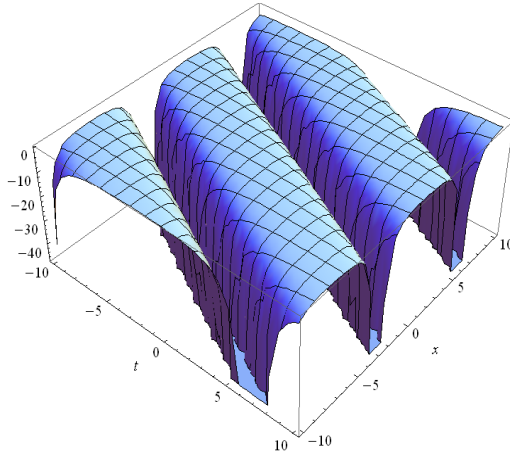

Figure 3: Sketch of the periodic singular solution $u_{1,3}$ in (4.1.19) to the KdV equation for $\delta = 1$, $\omega = 0.5$ within $-10 \leq x, t \leq 10$.

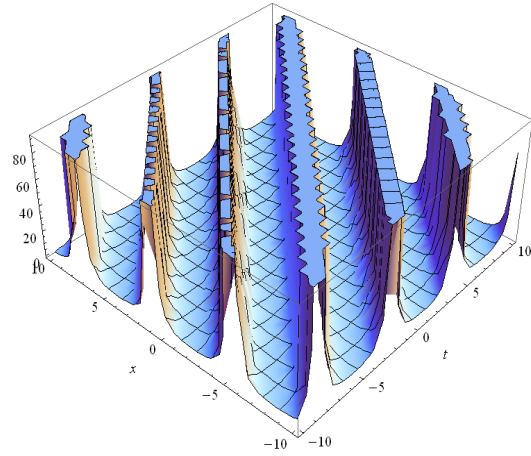

Figure 4: Sketch of singular periodic solution $u_{1,4}$ in (4.1.20) to the KdV equation for $\delta = -1$, $\omega = 1$ within $-10 \leq x, t \leq 10$.

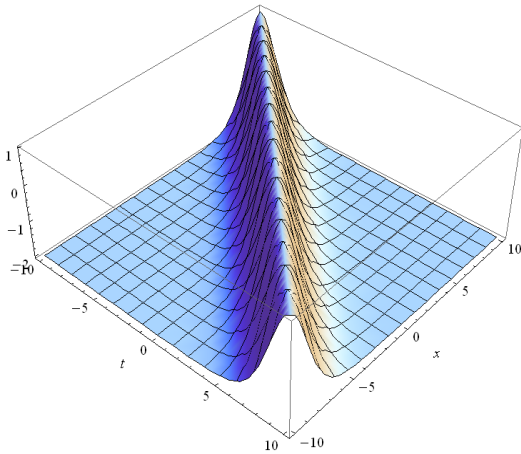

Figure 5: Sketch of the bell shape soliton $u_{1,5}$ in (4.1.23) to the KdV equation for $\delta = 1$, $\omega = -1$ within $-10 \leq x, t \leq 10$.

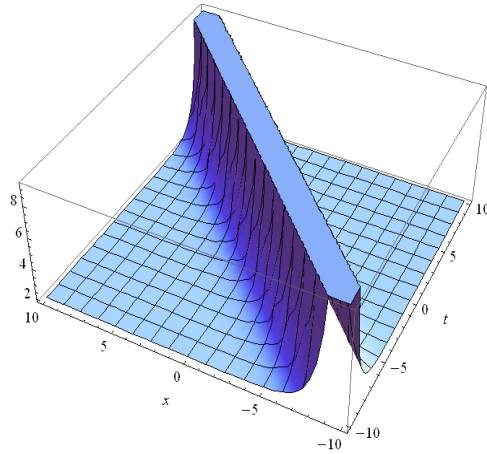

Figure 6: Sketch of the singular bell shape soliton $u_{1,6}$ in (4.1.24) to the KdV equation for $\delta = -1$, $\omega = 1$ within $-10 \leq x, t \leq 10$.

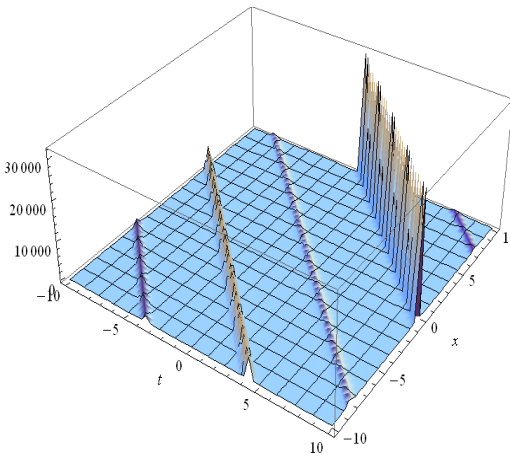

Figure 7: Sketch of the singular periodic solution $u_{1,7}$ in (4.1.25) to the KdV equation for $\delta = -1.5$, $\omega = -1$ within $-10 \leq x, t \leq 10$.

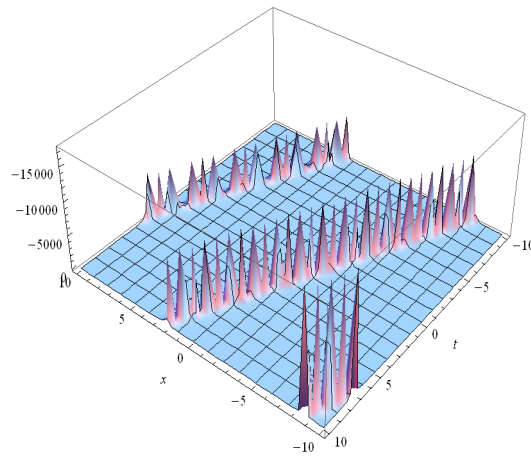

Figure 8: Sketch of the singular periodic solution $u_{1,8}$ in (4.1.26) to the KdV equation for $\delta = -1.5$, $\omega = 0.5$ within $-10 \leq x, t \leq 10$.

5.1(b): The Boussinesq Equation

In this sub-section, we have drawn the diagrams of the obtained solutions to the Boussinesq equation through the MSE method and represented in figures 9-16 with the help of symbolic computation software, such as Mathematica:

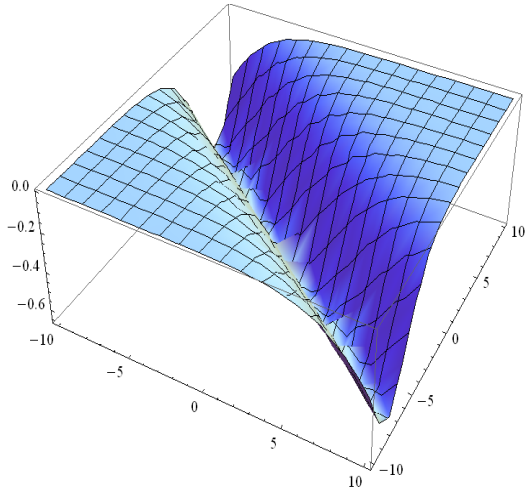

Figure 9: Shape of the anti-bell type soliton $u_{1,9}$ shown in (4.1.37) to the Boussinesq equation for $\omega = -0.75$ within $-10 \leq x, t \leq 10$.

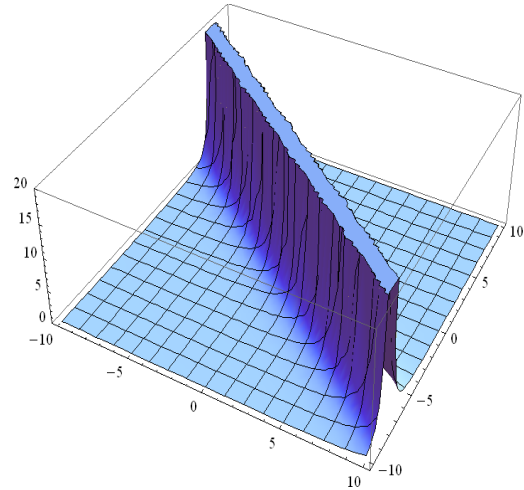

Figure 10: Shape of the singular bell type soliton $u_{1,10}$ shown in (4.1.38) to the Boussinesq equation for $\omega = -0.75$ within $-10 \leq x, t \leq 10$.

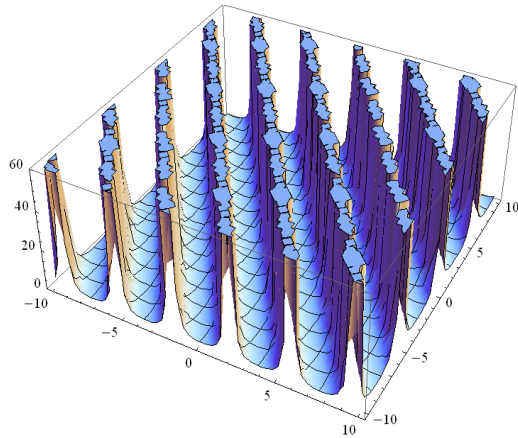

Figure 11: Shape of the singular periodic solution $u_{1,11}$ shown in (4.1.39) to the Boussinesq equation for $\omega = -1.5$ within $-10 \leq x, t \leq 10$.

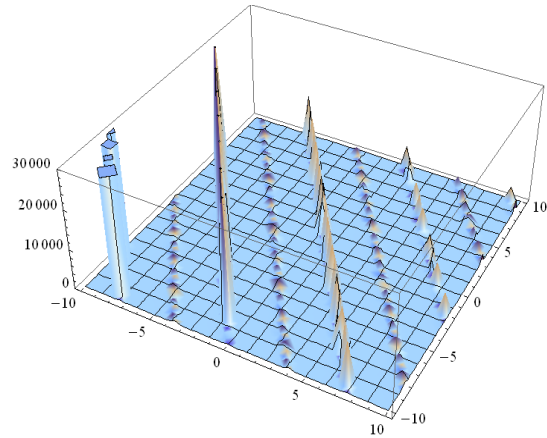

Figure 12: Shape of the singular periodic solution $u_{1,12}$ shown in (4.1.40) to the Boussinesq equation for $\omega = -1.5$ within $-10 \leq x, t \leq 10$.

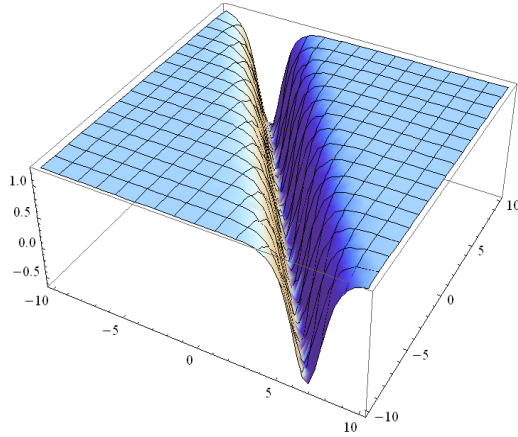

Figure 13: Shape of anti-bell type soliton $u_{1,13}$ shown in (4.1.43) to the Boussinesq equation for $\omega = -1.5$ within $-10 \leq x, t \leq 10$.

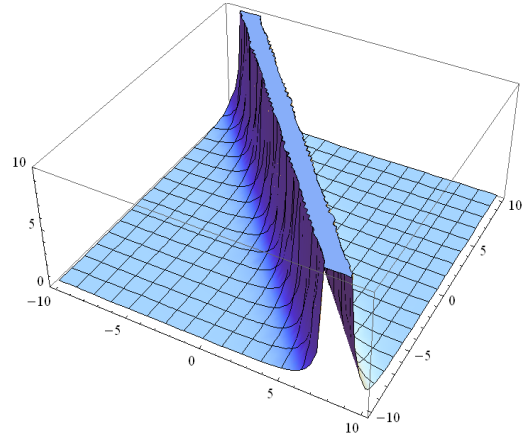

Figure 14: Shape of the singular bell type soliton $u_{1,14}$ shown in (4.1.44) to the Boussinesq equation for $\omega = -1.2$ within $-10 \leq x, t \leq 10$.

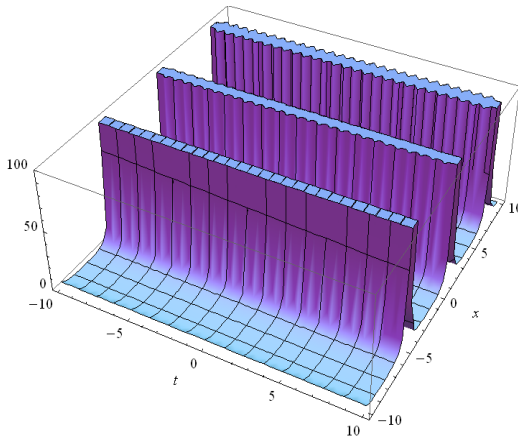

Figure 15: Shape the singular periodic solution $u_{1,15}$ shown in (4.1.45) to the Boussinesq equation for $\omega = 0.001$ within $-10 \leq x, t \leq 10$.

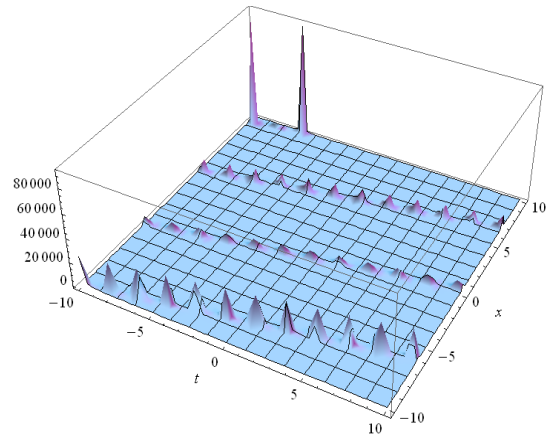

Figure 16: Shape the singular multiple solution $u_{1,16}$ shown in (4.1.46) to the Boussinesq equation for $\omega = 0.2$ within $-10 \leq x, t \leq 10$.

5.1(c): The Fifth-order KdV Equation

In this sub-section, we have illustrated the figures of the obtained traveling solutions to the fifth-order KdV equation by the MSE method represented in the following figures 17-24 through the assistance of symbolic computation software:

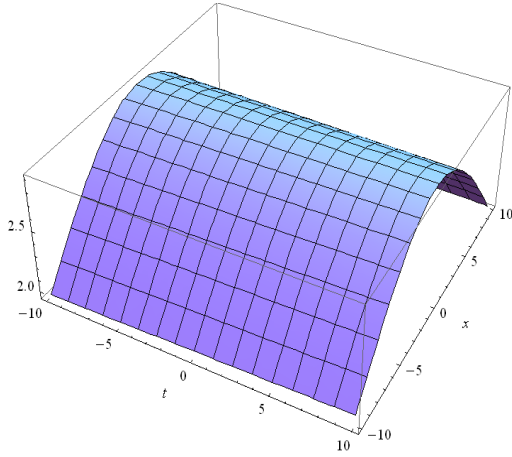

Figure 17: Structure of bell shape soliton $u_{1,17}$ set down in (4.1.59) to the fifth-order KdV equation for $\alpha = -1$, $\beta = 1$, $\gamma = -1.5$ and $\mu = -1$ within $-10 \leq x, t \leq 10$.

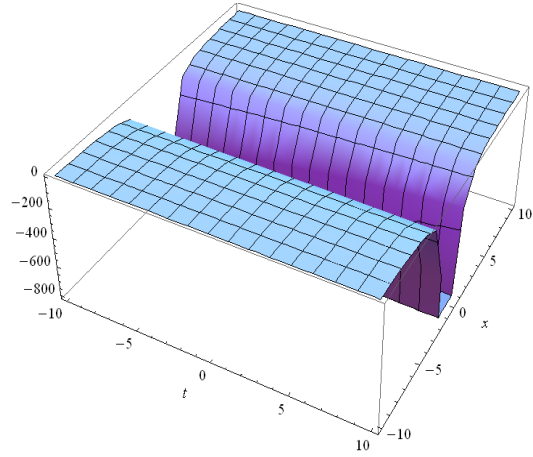

Figure 18: Structure of singular anti-bell shape soliton $u_{1,18}$ in (4.1.60) to the fifth-order KdV equation for $\alpha = -1$, $\beta = 1$, $\gamma = -1.5$ and $\mu = -1$ within $-10 \leq x, t \leq 10$.

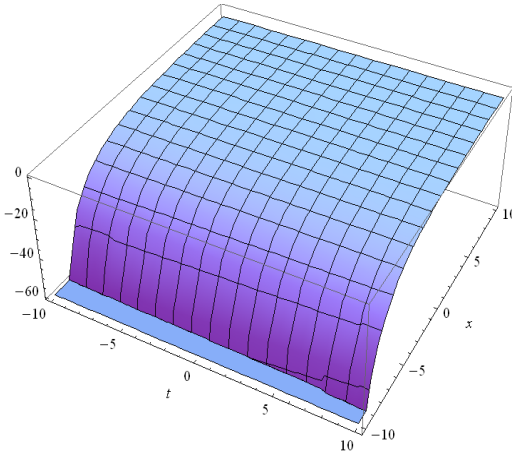

Figure 19: Structure of singular solution $u_{1,19}$ set down in (4.1.61) to the fifth-order KdV equation for $\alpha = 1$, $\beta = 1$, $\gamma = 1.5$ and $\mu = -1$ within $-10 \leq x, t \leq 10$.

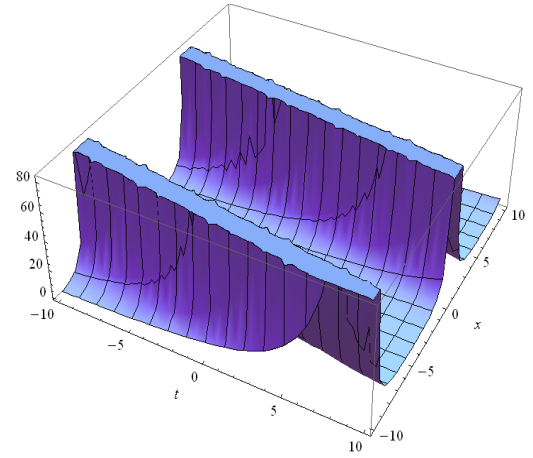

Figure 20: Structure of singular periodic solution $u_{1,20}$ set down in (4.1.62) to the fifth-order KdV equation for $\alpha = -1$, $\beta = 1$, $\gamma = -1$ and $\mu = -2$ within $-10 \leq x, t \leq 10$.

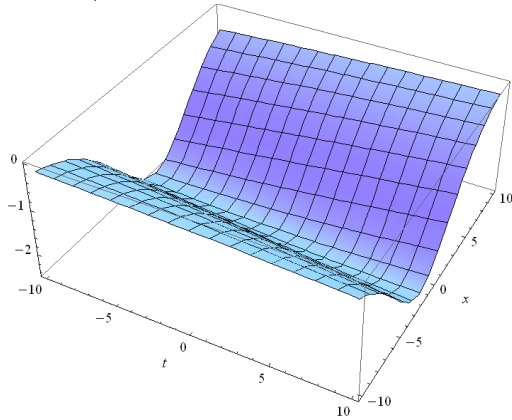

Figure 21: Structure of anti-bell type soliton $u_{1,21}$ set down in (4.1.65) to the fifth-order KdV equation for $\alpha = 1$, $\beta = 1$, $\gamma = -1$ and $\mu = -1$ within $-10 \leq x, t \leq 10$.

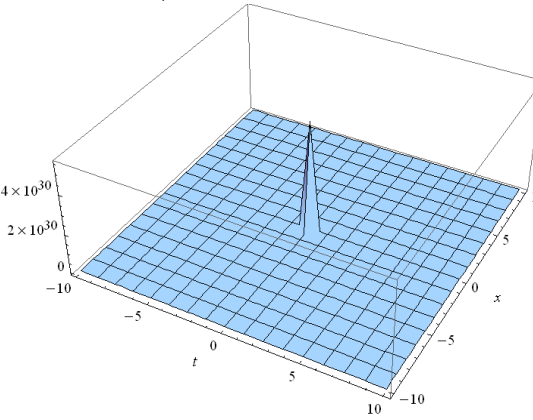

Figure 22: Structure of the single soliton $u_{1,22}$ set down in (4.1.66) to the fifth-order KdV equation for $\alpha = -1$, $\beta = 1$, $\gamma = 0.5$ and $\mu = -1$ within $-10 \leq x, t \leq 10$.

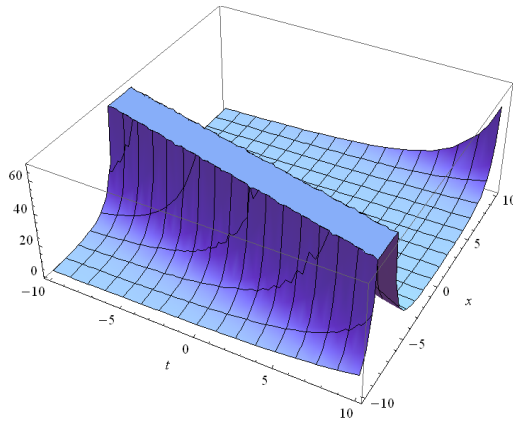

Figure 23: Structure of singular periodic solution $u_{1,23}$ set down in (4.1.67) to the fifth-order KdV equation for $\alpha = -2$, $\beta = 2$, $\gamma = 2$ and $\mu = -2$ within $-10 \leq x$, $t \leq 10$.

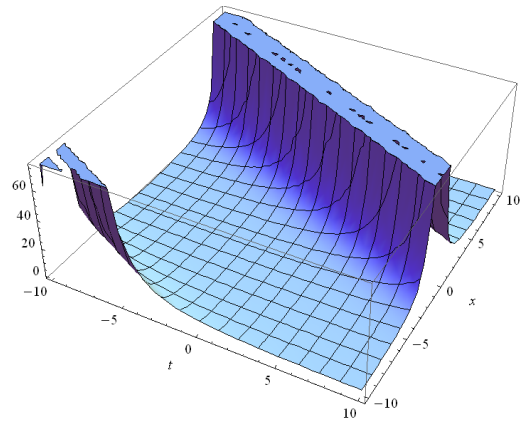

Figure 24: Structure of the singular periodic solution $u_{1,24}$ set down in (4.1.68) to the fifth-order KdV equation for $\alpha = 2$, $\beta = -2$, $\gamma = -2$ and $\mu = 2$ within $-10 \leq x$, $t \leq 10$.

5.1(d): The Modified Schamel Equation for Acoustic Waves in Plasma Physics

In this sub-section, we have shown the subsequent figures of the obtained solitary solutions to the modified Schamel equation for acoustic waves in plasma physics via the MSE method and presented in the figures 25-32 with the help of symbolic computation software:

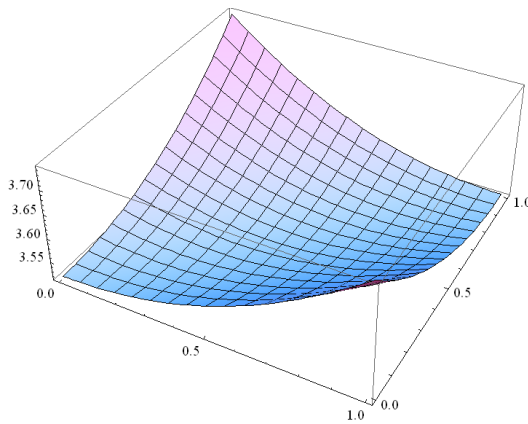

Figure 25: Form of the anti-bell shape soliton $u_{1,25}$ written down in (4.1.85) to the modified Schamel equation for $k = -2$, $\delta = -2$, and $\omega = -2$ within $0 \leq x$, $t \leq 1$.

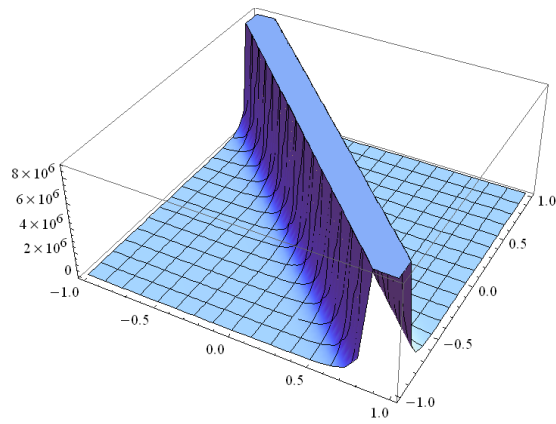

Figure 26: Form of singular bell shape soliton $u_{1,26}$ written down in (4.1.86) to the modified Schamel equation for $k = -2$, $\delta = -2$, and $\omega = -2$ within $-1 \leq x$, $t \leq 1$.

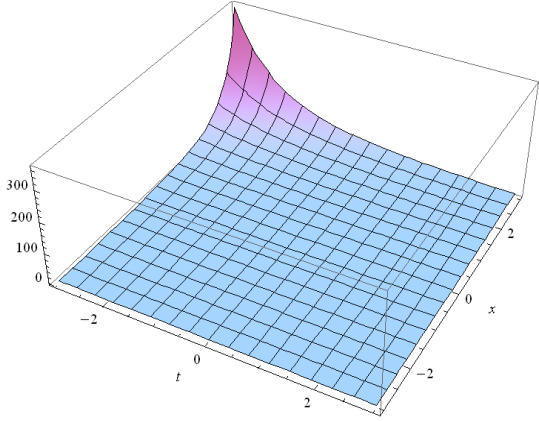

Figure 27: Form of the figure of a part of the singular periodic solution $u_{1,27}$ written down in (4.1.87) to the modified Schamel equation for $k = -2$, $\delta = -2$, $\omega = -1$ within $-3 \leq x, t \leq 3$.

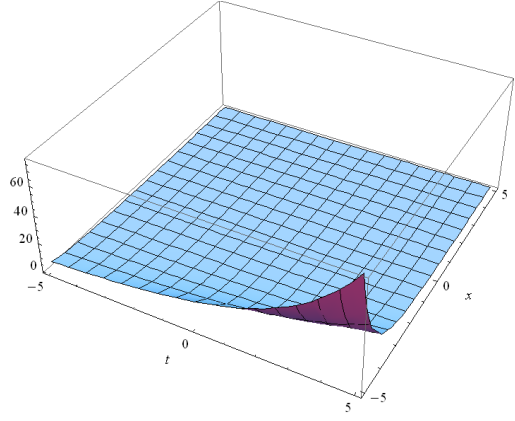

Figure 28: Form of the figure of a part of the singular periodic solution $u_{1,28}$ written down in (4.1.88) to the modified Schamel equation for $k = -2$, $\delta = -2$, $\omega = -0.5$ within $-5 \leq x, t \leq 5$.

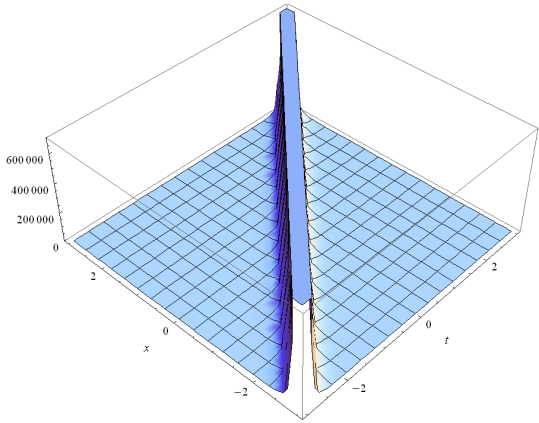

Figure 29: Form of singular bell shape soliton $u_{1,29}$ written down in (4.1.92) to the modified Schamel equation for $k = -1$, $\delta = -1$, and $\omega = -1$ within $-3 \leq x, t \leq 3$.

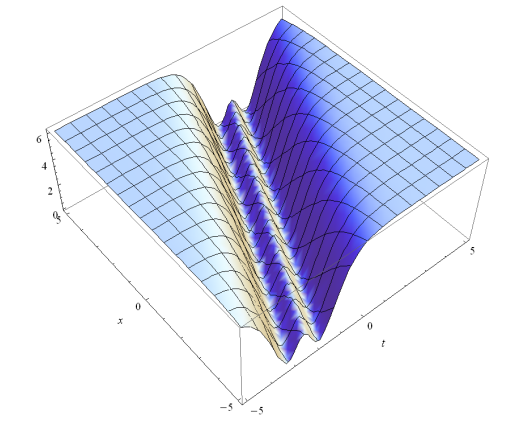

Figure 30: Form of the solution $u_{1,30}$ written down in (4.1.93) to the modified Schamel equation for $k = 1$, $\delta = -0.5$, $\omega = 2$ within $-5 \leq x, t \leq 5$.

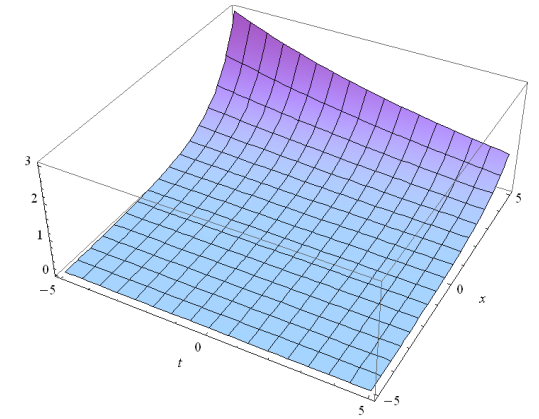

Figure 31: Form of the figure as the part of the singular periodic solution $u_{1,31}$ written down in (4.1.94) to the modified Schamel equation for $k = -2$, $\delta = -2$, $\omega = 0.3$ with $-5 \leq x, t \leq 5$.

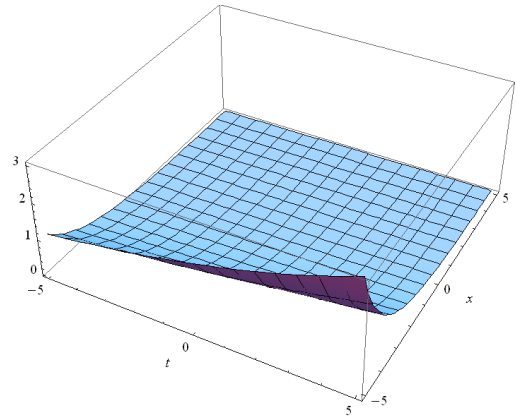

Figure 32: Form of the figure as the part of the singular periodic solution $u_{1,32}$ written down in (4.1.95) to the modified Schamel equation for $k = 2$, $\delta = 2$, and $\omega = 0.3$ within $-5 \leq x, t \leq 5$.

5.1(e): The Modified Kadomtsev-Petviashvili (KP) Equation for Acoustic Waves in Plasma Physics

In this sub-section, we have drawn the diagrams of the obtained traveling solutions to the modified KP equation for acoustic waves in plasma physics by using the MSE method and represented in figures 33-40 with the aid of symbolic computation software:

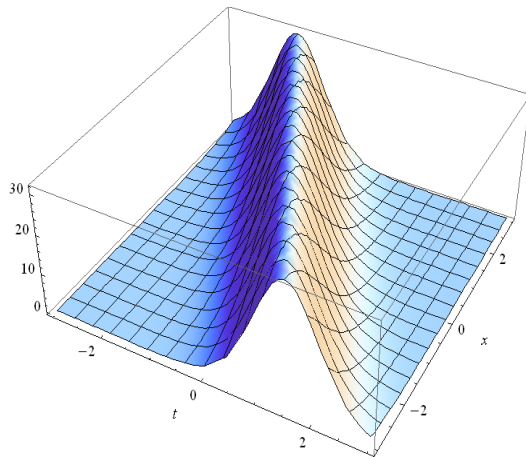

Figure 33: Diagram of the bell shape soliton $u_{1,33}$ mentioned in (4.1.112) to the modified KP equation for $k = -2$, $\alpha = -2$, $\beta = 2$, $\delta = -2$ and $\omega = -2$ within $-3 \leq x$, $t \leq 3$.

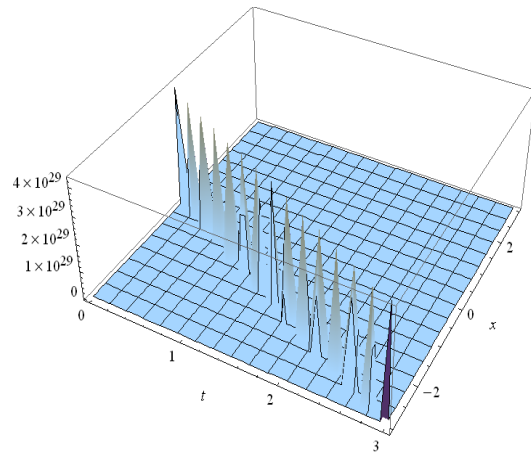

Figure 34: Diagram of the singular multi-soliton $u_{1,34}$ mentioned in (4.1.113) to the modified KP equation for $k = -1.5$, $\alpha = -1$, $\beta = 1$, $\delta = -1$ and $\omega = -1$ within $0 \leq t \leq 3$, $-3 \leq x \leq 3$

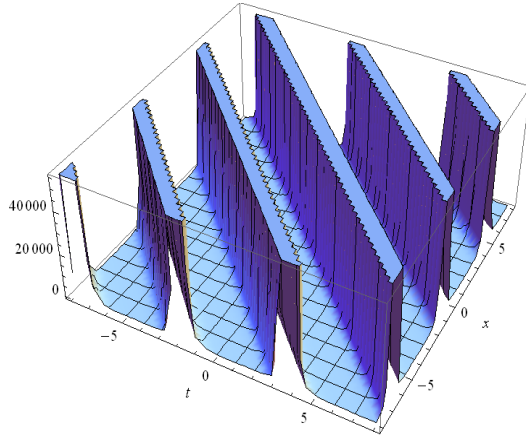

Figure 35: Diagram of the singular periodic solution $u_{1,35}$ mentioned in (4.1.114) to the modified KP equation for $k = 2$, $\alpha = 1$, $\beta = 1$, $\delta = 1$, $\omega = -1$ within $-8 \leq x$, $t \leq 8$.

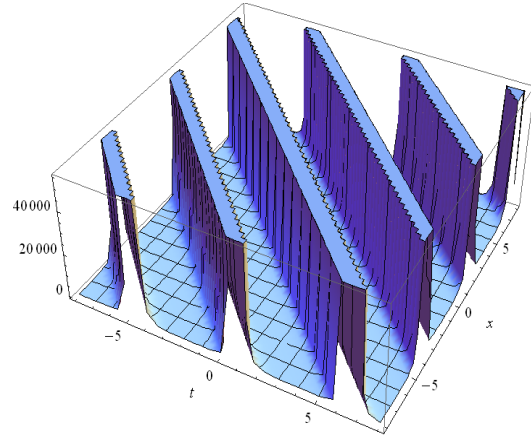

Figure 36: Diagram of the singular periodic solution $u_{1,35}$ mentioned in (4.1.115) to the modified KP equation for $k = 2$, $\alpha = 1$, $\beta = 1$, $\delta = 1$ and $\omega = -1$ within $-8 \leq x$, $t \leq 8$.

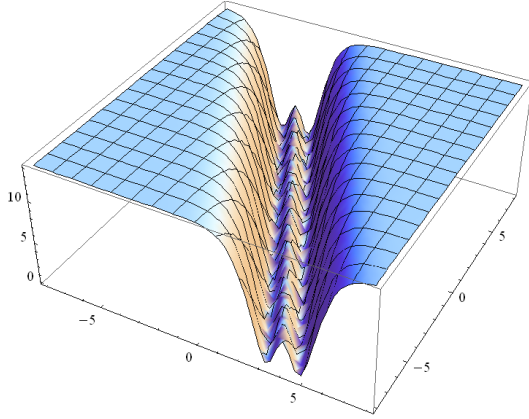

Figure 37: Diagram of the solution $u_{1,37}$ mentioned in (4.1.119) to the modified KP equation for $k = -2, \alpha = -2, \beta = -2, \delta = -2$ and $\omega = -2$ within $-8 \leq x, t \leq 8$.

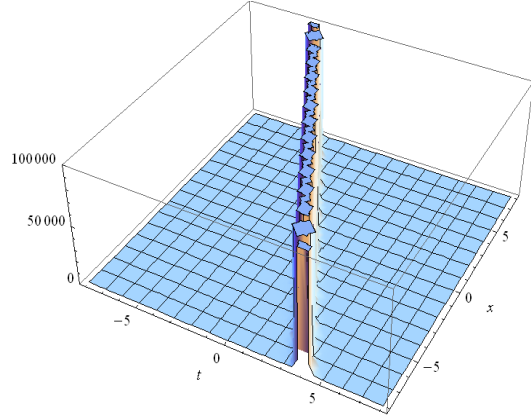

Figure 38: Diagram of the singular bell shape soliton $u_{1,38}$ mentioned in (4.1.120) to the modified KP equation for $k = -2, \alpha = -2, \beta = -2, \delta = -2$ and $\omega = -2$ within $-8 \leq x, t \leq 8$.

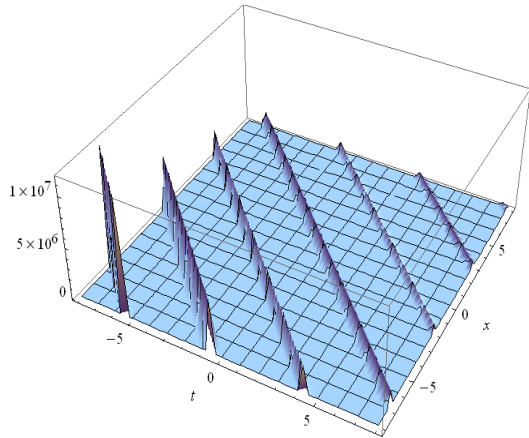

Figure 39: Diagram of the periodic solution $u_{1,39}$ mentioned in (4.1.121) to the modified KP equation for $k = -2, \alpha = -2, \beta = 0.45, \delta = -1$ and $\omega = -1$ within $-8 \leq x, t \leq 8$.

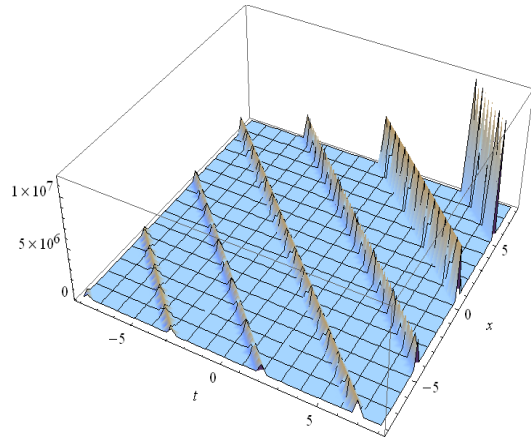

Figure 40: Diagram of the periodic solution $u_{1,40}$ mentioned in (4.1.122) to the modified KP equation for $k = -2, \alpha = -2, \beta = 0.45, \delta = -1$ and $\omega = -1$ within $-8 \leq x, t \leq 8$.

5.1(f): The Strain Wave Equation in Microstructured Solids

In this sub-section, we have illustrated the graphs of the solutions to the strain wave equation in microstructured solids for non-dissipative and dissipative cases obtained through the MSE method and represent in the figures 41-48 for non-dissipative case and the figures 49-64 for dissipative case with the support of symbolic computation software:

5.1(f)-I: The Non-dissipative Case

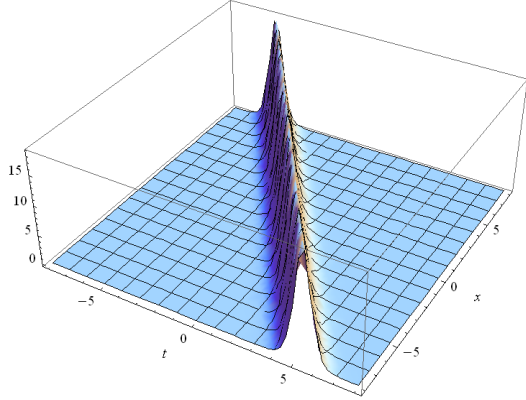

Figure 41: Plot of bell shape soliton $u_{1,41}$ set down in (4.1.135) to the strain wave equation in microstructured solids for non-dissipative case when $\varepsilon = 0.1$, $\alpha_1 = 1, \alpha_3 = 1$, $\alpha_4 = 1.25$ and $\omega = -1.5$ within $-8 \leq x, t \leq 8$.

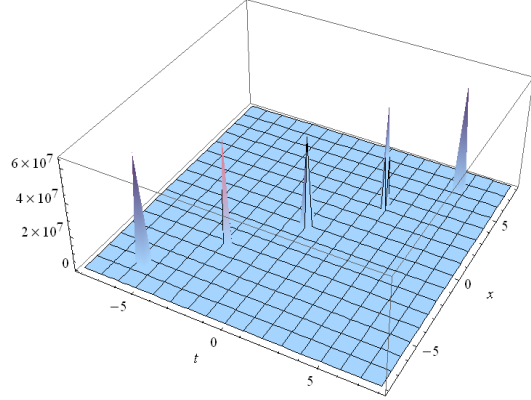

Figure 42: Plot of multi-soliton $u_{1,42}$ set down in (4.1.136) to the strain wave equation in microstructured solids for non-dissipative case when $\varepsilon = 0.1$, $\alpha_1 = -2, \alpha_3 = 2$, $\alpha_4 = 2$ and $\omega = 1.1$ within $-8 \leq x, t \leq 8$.

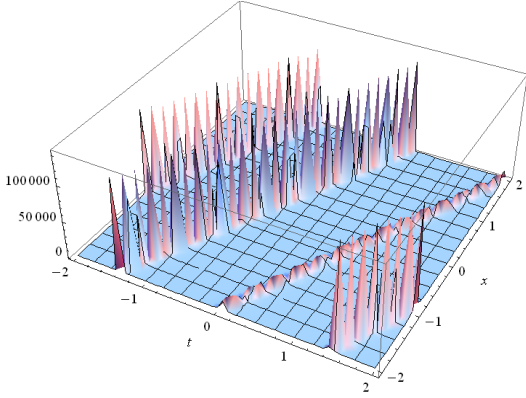

Figure 43: Plot of singular periodic solution $u_{1,43}$ set down in (4.1.137) to the strain wave equation in microstructured solids for non-dissipative case when $\varepsilon = 0.1$, $\alpha_1 = 2, \alpha_3 = -2$, $\alpha_4 = -2$ and $\omega = 2$ within $-2 \leq x, t \leq 2$.

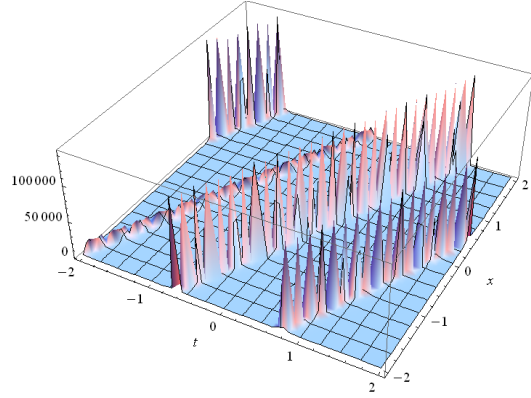

Figure 44: Plot of singular periodic solution $u_{1,44}$ written down in (4.1.138) to the strain wave equation in microstructured solids for non-dissipative case when $\varepsilon = 0.1$, $\alpha_1 = 2, \alpha_3 = -2$, $\alpha_4 = -2$ and $\omega = 2$ within $-2 \leq x, t \leq 2$.

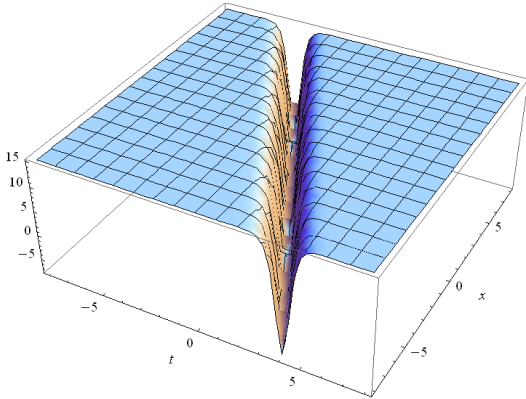

Figure 45: Plot of anti-bell shape soliton $u_{1,45}$ written down in (4.1.141) to the strain wave equation in microstructured solids for non-dissipative case when $\varepsilon = 0.1$, $\alpha_1 = 2, \alpha_3 = -2$, $\alpha_4 = -2$ and $\omega = -2$ within $-8 \leq x, t \leq 8$.

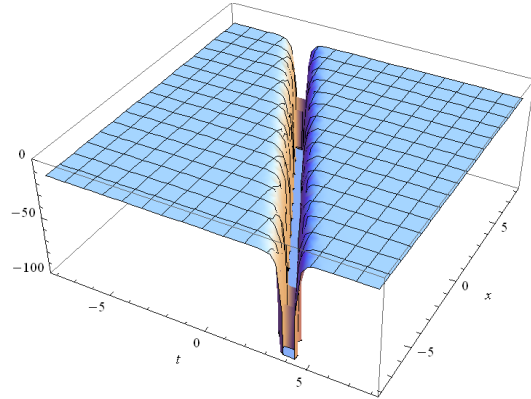

Figure 46: Plot of singular anti-bell shape soliton $u_{1,46}$ written down in (4.1.142) to the strain wave equation in microstructured solids for non-dissipative case when $\varepsilon = 0.1$, $\alpha_1 = -2, \alpha_3 = -2$, $\alpha_4 = -2$ and $\omega = -2$ within $-8 \leq x, t \leq 8$.

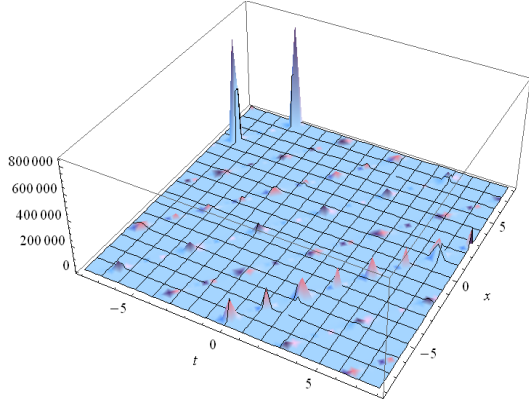

Figure 47: Plot of periodic multi-solution $u_{1,47}$ mentioned in (4.1.143) to the strain wave equation in microstructured solids for non-dissipative case when $\varepsilon = 0.1$, $\alpha_1 = -2, \alpha_3 = -1$, $\alpha_4 = 1$ and $\omega = 1.25$ within $-8 \leq x$, $t \leq 8$.

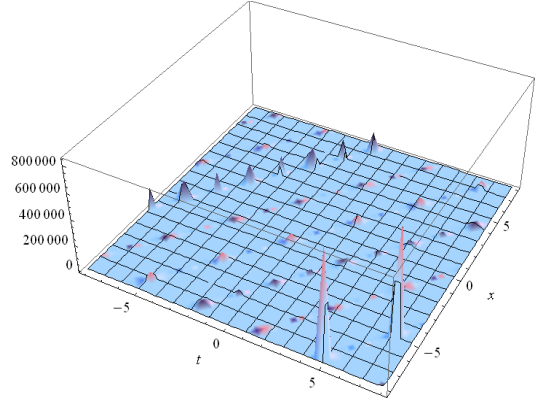

Figure 48: Plot of periodic multi-solution $u_{1,48}$ mentioned in (4.1.144) to the strain wave equation in microstructured solids for non-dissipative case when $\varepsilon = 0.1$, $\alpha_1 = -2, \alpha_3 = -1$, $\alpha_4 = 1$ and $\omega = 1.25$ within $-8 \leq x$, $t \leq 8$.

5.1(f)-II: The Dissipative Case

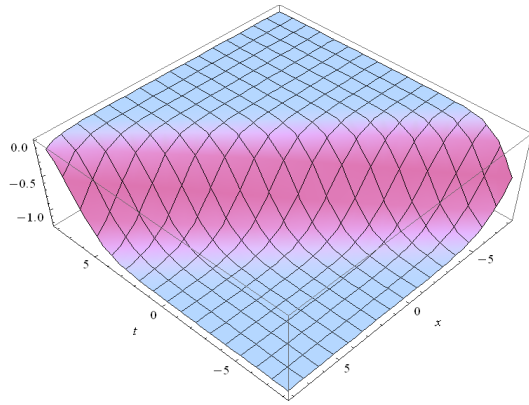

Figure 49: Sketch of the kink soliton $u_{1,49}$ shown in (4.1.156) to the strain wave equation for dissipative case when $\varepsilon = 0.1$, $\alpha_1 = -2$, $\alpha_2 = -2$, $\alpha_3 = -2$ and $\alpha_4 = -2$ within $-8 \leq x$, $t \leq 8$ for $\omega = \theta_1$.

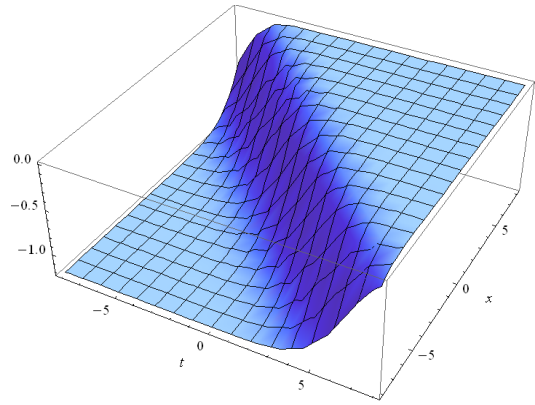

Figure 50: Sketch of the kink soliton $u_{1,49}$ shown in (4.1.156) to the strain wave equation for dissipative case when $\varepsilon = 0.1$, $\alpha_1 = -2$, $\alpha_2 = -2$, $\alpha_3 = -2$ and $\alpha_4 = -2$ within $-8 \leq x$, $t \leq 8$ for $\omega = -\theta_1$.

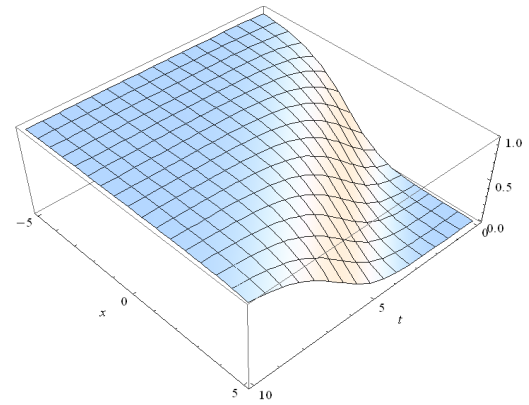

Figure 51: Sketch of the kink soliton $u_{1,49}$ shown in (4.1.156) to the strain wave equation for dissipative case when $\varepsilon = 0.1$, $\alpha_1 = -2$, $\alpha_2 = -2$, $\alpha_3 = -2$ and $\alpha_4 = -2$ within $0 \leq t \leq 10$, $-5 \leq x \leq 5$ for $\omega = \theta_2$.

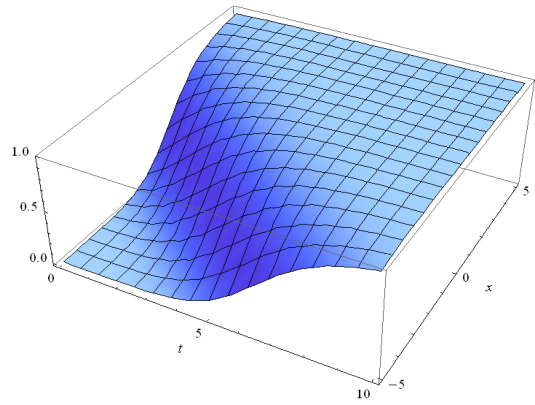

Figure 52: Shape of the kink soliton $u_{1,49}$ shown in (4.1.156) to the strain wave equation for dissipative case when $\varepsilon = 0.1$, $\alpha_1 = -2$, $\alpha_2 = -2$, $\alpha_3 = -2$ and $\alpha_4 = -2$ within $0 \leq t \leq 10$, $-5 \leq x \leq 5$ for $\omega = -\theta_2$.

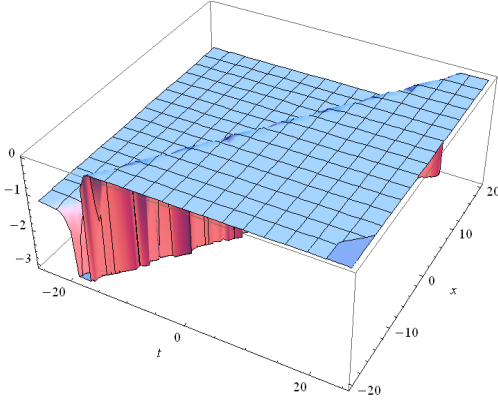

Figure 53: Sketch of the singular solution $u_{1,50}$ shown in (4.1.157) to the strain wave equation for dissipative case when $\varepsilon = 0.1$, $\alpha_1 = -2$, $\alpha_2 = -2$, $\alpha_3 = -2$ and $\alpha_4 = -2$ within $-25 \leq t \leq 25$, $-20 \leq x \leq 20$ for $\omega = \theta_1$.

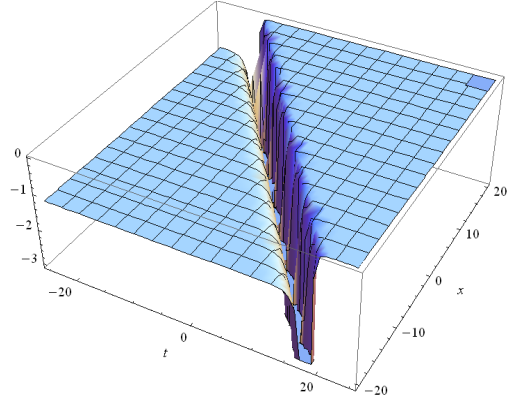

Figure 54: Sketch of the singular solution $u_{1,50}$ shown in (4.1.157) to the strain wave equation for dissipative case when $\varepsilon = 0.1$, $\alpha_1 = -2$, $\alpha_2 = -2$, $\alpha_3 = -2$, $\alpha_4 = -2$ within the range $-25 \leq t \leq 25$, $-20 \leq x \leq 20$ for $\omega = -\theta_1$.

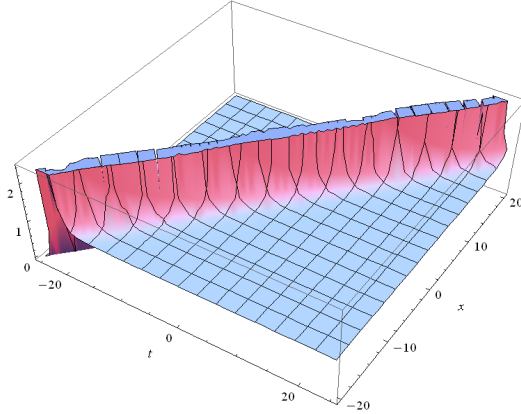

Figure 55: Sketch of the singular solution $u_{1,50}$ shown in (4.1.157) to the strain wave equation for dissipative case when $\varepsilon = 0.1$, $\alpha_1 = -2$, $\alpha_2 = -2$, $\alpha_3 = -2$ and $\alpha_4 = -2$ within $-25 \leq t \leq 25$, $-20 \leq x \leq 20$ for $\omega = \theta_2$.

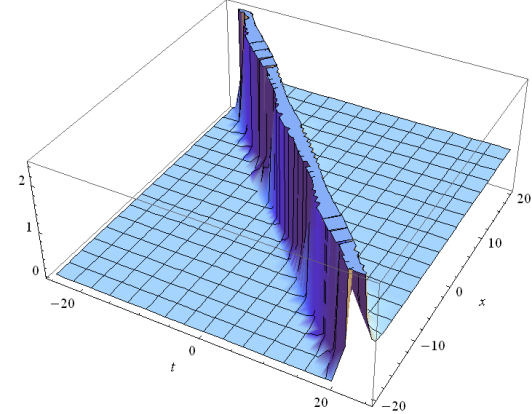

Figure 56: Sketch of the singular solution $u_{1,50}$ shown in (4.1.157) to the strain wave equation for dissipative case when $\varepsilon = 0.1$, $\alpha_1 = -2$, $\alpha_2 = -2$, $\alpha_3 = -2$ and $\alpha_4 = -2$ within $-25 \leq t \leq 25$, $-20 \leq x \leq 20$ for $\omega = -\theta_2$.

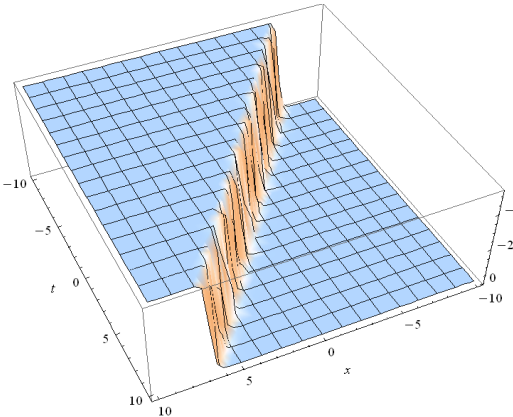

Figure 57: Sketch of the kink solution $u_{1,51}$ shown in (4.1.160) to the strain wave equation for dissipative case when $\varepsilon = 0.1$, $\alpha_1 = 1$, $\alpha_2 = 1$, $\alpha_3 = 0.5$ and $\alpha_4 = 1$ within $-10 \leq x, t \leq 10$ for $\omega = \vartheta_1$.

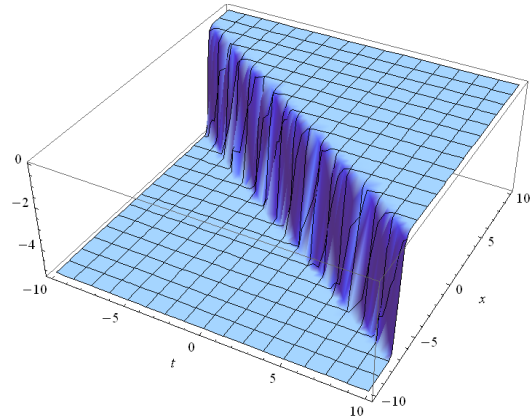

Figure 58: Sketch of the steeped kink solution $u_{1,51}$ shown in (4.1.160) to the strain wave equation for dissipative case when $\varepsilon = 0.1$, $\alpha_1 = 1$, $\alpha_2 = 1$, $\alpha_3 = 0.5$ and $\alpha_4 = 1$ within $-10 \leq x, t \leq 10$ for $\omega = -\vartheta_1$.

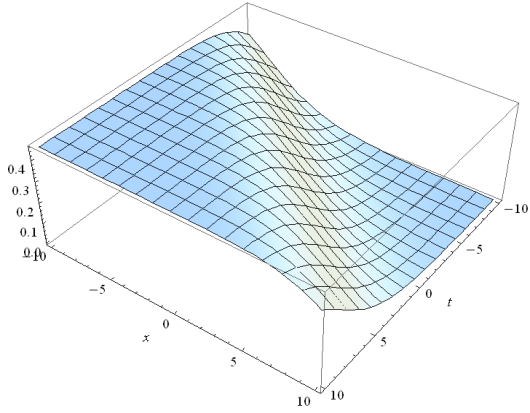

Figure 59: Sketch of the kink solution $u_{1,51}$ in (4.1.160) to the strain wave equation for dissipative case when $\varepsilon = 0.1$, $\alpha_1 = 1$, $\alpha_2 = 1$, $\alpha_3 = 0.5$ and $\alpha_4 = 1$ within $-10 \leq x$, $t \leq 10$ for $\omega = \vartheta_2$.

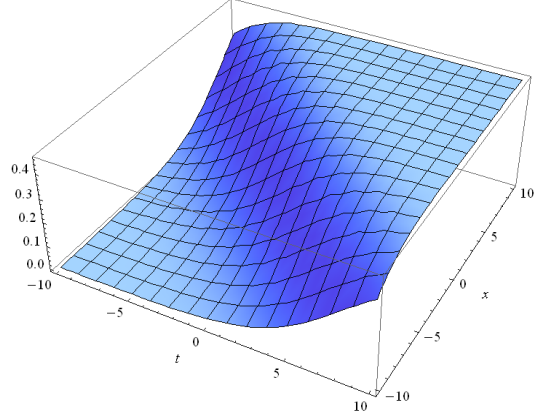

Figure 60: Sketch of the kink solution $u_{1,51}$ in (4.1.160) to the strain wave equation for dissipative case when $\varepsilon = 0.1$, $\alpha_1 = 1$, $\alpha_2 = 1$, $\alpha_3 = 0.5$ and $\alpha_4 = 1$ within $-10 \leq x$, $t \leq 10$ for $\omega = -\vartheta_2$.

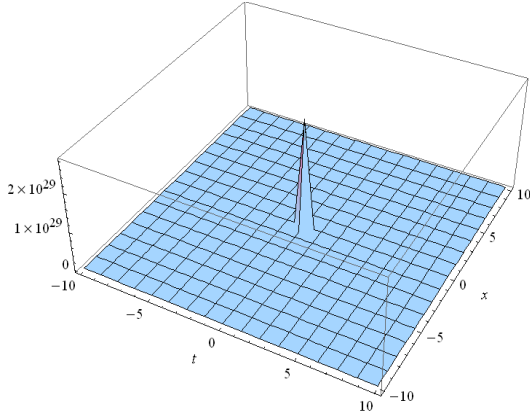

Figure 61: Sketch of the single soliton solution $u_{1,52}$ in (4.1.161) to the strain wave equation for dissipative case when $\varepsilon = 0.1$, $\alpha_1 = 1$, $\alpha_2 = 1$, $\alpha_3 = 0.5$ and $\alpha_4 = 1$ within $-10 \leq x$, $t \leq 10$ for $\omega = \vartheta_1$.

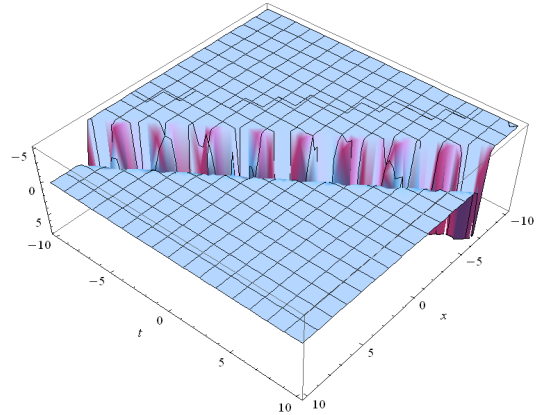

Figure 62: Sketch of the solution $u_{1,52}$ in (4.1.161) to the strain wave equation for dissipative case when $\varepsilon = 0.1$, $\alpha_1 = 1$, $\alpha_2 = 1$, $\alpha_3 = 0.5$ and $\alpha_4 = 1$ within $-10 \leq x$, $t \leq 10$ for $\omega = -\vartheta_1$.

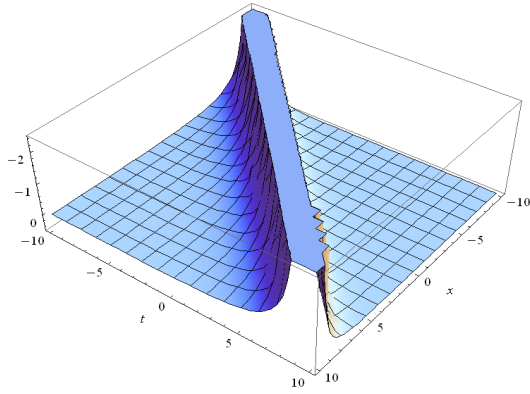

Figure 63: Sketch of the singular kink type solution $u_{1,52}$ in (4.1.161) to the strain wave equation for dissipative case when $\varepsilon = 0.1$, $\alpha_1 = 1$, $\alpha_2 = 1$, $\alpha_3 = 0.5$ and $\alpha_4 = 1$ within $-10 \leq x$, $t \leq 10$ for $\omega = \vartheta_2$.

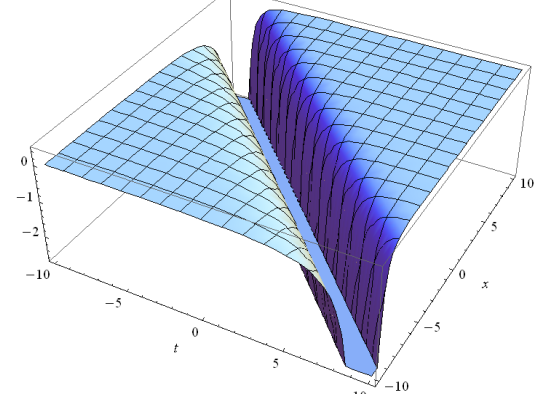

Figure 64: Sketch of the solution $u_{1,52}$ in (4.1.161) to the strain wave equation for dissipative case when $\varepsilon = 0.1$, $\alpha_1 = 1$, $\alpha_2 = 1$, $\alpha_3 = 0.5$ and $\alpha_4 = 1$ within $-10 \leq x$, $t \leq 10$ for $\omega = -\vartheta_2$.

5.2: The Physical Explanations

In this section, we have discussed the significance of the accomplished solutions through figures of the NLEEs studied in Chapter 4. NLEEs have different types solitary wave solutions, such as, soliton, singular soliton, bell shape soliton, anti-bell shape soliton, singular bell shape soliton, singular anti-bell shape soliton, kink, singular kink, periodic, singular periodic solution etc. In the following, we have described the nature of the derived solutions for different values of the parameters:

5.2(a): The KdV Equation

In this sub-section, we have described the behavior of the solutions to the KdV equation. By means of the MSE method, we have achieved eight solutions, $u_{1,1}$ to $u_{1,8}$ to the KdV equation. The solutions include bell shaped solitons, singular solitons, singular periodic solutions as a particular case of the generalized solitary wave solutions. The graphs are labeled as figure 1 to figure 8. The figure 1 of the solution $u_{1,1}$, shows that the solution represent anti-bell shape soliton for $\delta = -2$, $\omega = -1$ within $-10 \leq x, t \leq 10$. The solution $u_{1,2}$ written down in (4.1.18) represents the singular soliton solution. Its graph is drawn for $\delta = 1$, $\omega = 1$ within $-10 \leq x, t \leq 10$ and labeled as figure 2. The solution $u_{1,3}$ set down in (4.1.19) and the solution $u_{1,4}$ set down in (4.1.20) represent the periodic singular solution. Solution (4.1.19) is plotted for $\delta = 1$, $\omega = 0.5$ within $-10 \leq x, t \leq 10$ and labeled as figure 3. On the other hand, solution (4.1.20) is plotted for $\delta = -1$, $\omega = 1$ within $-10 \leq x, t \leq 10$ and labeled as figure 4. It is noted that the solution $u_{1,5}$ written down in (4.1.23) represents the bell shape soliton. Its figure is drawn for $\delta = 1$, $\omega = -1$ within $-10 \leq x, t \leq 10$ and labeled as figure 5. The solution $u_{1,6}$ written down in (4.1.24) is the singular bell type soliton. It is plotted for $\delta = -1$, $\omega = 1$ within $-10 \leq x, t \leq 10$ and assigned in figure 6. Moreover, the solutions $u_{1,7}$ written

down in (4.1.25) and the solution $u_{1,8}$ written down in (4.1.26) are singular periodic solution. Solution $u_{1,7}$ is plotted for $\delta = -1.5$, $\omega = -1$ within $-10 \leq x$, $t \leq 10$ and assigned in figure 7 and solution $u_{1,8}$ is plotted for $\delta = -1.5$, $\omega = 0.5$ within $-10 \leq x$, $t \leq 10$ and assigned in figure 8.

5.2(b): The Boussinesq Equation

In this sub-section, we have interpreted the characteristics of the achieved solutions to the Boussinesq equation by the MSE method.

We have derived different types of solutions to the Boussinesq equation (4.1.27) in Chapter 4 through the MSE method. The solutions involve solitary solutions, solitons, singular solitons and singular periodic solutions and displayed in the figure 9 to figure 16. The solution $u_{1,9}$ to Eq. (4.1.37) and the solution $u_{1,13}$ to Eq. (4.1.43) are the anti-bell shape soliton solution to the Boussinesq equation (4.1.27). The figure of $u_{1,9}$ is sketch for $\omega = -0.75$ and labeled as figure 9. On the other hand, the figure of $u_{1,13}$ is sketch for $\omega = -1.5$ and labeled as figure 13 within the range $-10 \leq x$, $t \leq 10$ which gives the inner information of the physical phenomena. Solution $u_{1,10}$ to Eq. (4.1.38) and the solution $u_{1,14}$ to Eq. (4.1.44) to the Boussinesq equation are singular bell type soliton solution. In figure 10, we have sketched the solution $u_{1,10}$ for $\omega = -0.75$ within the range $-10 \leq x$, $t \leq 10$ and in figure 14, we have sketched the solution $u_{1,14}$ for $\omega = -1.5$ within the same range. The solutions $u_{1,11}$ to Eq. (4.1.39), $u_{1,12}$ to Eq. (4.1.40), $u_{1,15}$ to Eq. (4.1.45) and the solution $u_{1,16}$ to Eq. (4.1.46) are singular periodic solutions. In figure 11, we sketch the solution $u_{1,11}$ for $\omega = -1.5$, in figure 12, the solution $u_{1,12}$ has been sketched for $\omega = -1.5$, in figure 15, we sketch the solution $u_{1,15}$ for $\omega = 0.001$ and in figure 16, we sketch the solution $u_{1,16}$ for $\omega = 0.2$ within the range $-10 \leq x$, $t \leq 10$, which described the characteristics of the period solution.

5.2(c): The Fifth-order KdV Equation

In this sub-section, we have explained the nature of the derived solutions to the fifth-order KdV equation (4.1.47).

Using the MSE method, we have derived several solutions to the fifth-order KdV equation (4.1.47). These solutions attach the solitary wave solutions or solitons, singular solitons and singular periodic solutions and showed in the figure 17 to figure 24. In figure 17, we have illustrated the soliton $u_{1,17}$ shown in (4.1.59). It represents bell shape solitary wave soliton for $\alpha = -1$, $\beta = 1$, $\gamma = -1.5$ and $\mu = -1$ within the plot limit $-10 \leq x$, $t \leq 10$ and in the figure 18, we have illustrated the singular soliton $u_{1,18}$ shown in (4.1.60) to the fifth-order KdV equation (4.1.47). It shows that the soliton $u_{1,18}$ is a anti-bell shape singular soliton for $\alpha = -1$, $\beta = 1$, $\gamma = -1.5$ and $\mu = -1$ within the plot limit $-10 \leq x$, $t \leq 10$. Also the singular solution $u_{1,19}$ shown in (4.1.61) denoted by the figure 19. This figure depicted the character of the solution is a part of the periodic singular solution for a small region when $\alpha = 1$, $\beta = 1$, $\gamma = 1.5$ and $\mu = -1$ within $-10 \leq x$, $t \leq 10$. Moreover the solution $u_{1,20}$ shown in (4.1.62) denoted by the figure 20 expresses the singular periodic solution for $\alpha = -1$, $\beta = 1$, $\gamma = -1$ and $\mu = -2$ within the plot limit $-10 \leq x$, $t \leq 10$. Again the anti-bell shape soliton $u_{1,21}$ shown in (4.1.65) is denoted by the figure 21. The figure 21, shows the solution $u_{1,21}$ is a anti-bell shape soliton, when $\alpha = 1$, $\beta = 1$, $\gamma = -1$ and $\mu = -1$ within the plot limit $-10 \leq x$, $t \leq 10$. And the singular soliton $u_{1,22}$ shown in (4.1.66) is denoted by the figure 22. This figure explains single soliton wave, when $\alpha = -1$, $\beta = 1$, $\gamma = 0.5$ and $\mu = -1$ within the plot limit $-10 \leq x$, $t \leq 10$. Furthermore the singular solution $u_{1,23}$ shown in (4.1.67) presented by the figure 23. It depicts the character of the solution $u_{1,23}$ is a periodic singular solution for small region, when $\alpha = -2$, $\beta = 2$, $\gamma = 2$ and $\mu = -2$ within the

plot limit $-10 \leq x, t \leq 10$ and also the solution $u_{1,24}$ shown in (4.1.68) presented by the figure 24. The figure 24 describes the solution $u_{1,24}$ is a singular periodic solution for $\alpha = 2, \beta = -2, \gamma = -2$ and $\mu = 2$ within the plot limit $-10 \leq x, t \leq 10$.

5.2(d): The Modified Schamel Equation for Acoustic Waves in Plasma Physics

In this sub-section, we have discussed the attribute of the attain solutions to the modified Schamel equation for acoustic waves in plasma physics (4.1.69).

By using the MSE method, we have derived various types of solution $u_{1,25}$ - $u_{1,32}$ to the modified schamel equation for acoustic waves in plasma physics (4.1.69). The solutions $u_{1,25}$ - $u_{1,28}$ are mentioned in (4.1.85)-(4.1.88) and the solutions $u_{1,29}$ - $u_{1,32}$ are mentioned in (4.1.92)-(4.1.95). These solutions construct solitons, singular solitons and periodic solutions and arranged in the figure 25 to figure 32. In figure 25, we have displayed the shape of the soliton $u_{1,25}$ for $k = -2, \delta = -2,$ and $\omega = -2$ within the area $0 \leq x, t \leq 1$. It is anti-bell shape solitary wave soliton. Figure 26 assessed the character of soliton $u_{1,26}$. The figure 26 illustrates a singular bell shape soliton for $k = -2, \delta = -2,$ and $\omega = -2$ within the area $-1 \leq x, t \leq 1$. Again, in figure 27, we have illustrated the shape of periodic solution $u_{1,27}$. This figure shows a part of the periodic singular solution for $k = -2, \delta = -2,$ and $\omega = -1$ within the area $-3 \leq x, t \leq 3$ and the solution $u_{1,28}$ is denoted by the figure 28. This figure sketches for $k = -2, \delta = -2,$ and $\omega = -0.5$ within the area $-5 \leq x, t \leq 5$, which represents a part of the periodic singular solution. On the other hand, the soliton $u_{1,29}$ exists in the figure 29. It shows a singular bell shape soliton for $k = -1, \delta = -1$ and $\omega = -1$ within the area $-3 \leq x, t \leq 3$ and the soliton $u_{1,30}$ exists in the figure 30. The figure 30 explicates an anti-bell type solitary wave soliton for $k = 1, \delta = -0.5$ and $\omega = 2$ within the range $-5 \leq x, t \leq 5$. Moreover the singular

solution $u_{1,31}$ is plotted in the figure 31 and the singular solution $u_{1,32}$ is plotted in the figure 32. The figure 31 sketches for $k = -2$, $\delta = -2$, $\omega = 0.3$ within the range $-5 \leq x, t \leq 5$ and the figure 32 sketches for $k = 2$, $\delta = 2$, and $\omega = 0.3$ within the same range, which represents as a part of the singular periodic solution.

5.2(e): The Modified Kadomtsev-Petviashvili (KP) Equation for Acoustic Waves in Plasma Physics

In this sub-section, we have set out the nature of the evaluated solutions to the modified KP equation for acoustic waves in plasma physics (4.1.96) via MSE method.

Through the MSE method, we have examined several solitary wave solutions to the modified KP equation for acoustic waves in plasma physics (4.1.96). The solutions $u_{1,33}$ - $u_{1,36}$ are declared in (4.1.112)-(4.1.115) and the solutions $u_{1,37}$ - $u_{1,40}$ are declared in (4.1.119)-(4.1.122). These solutions elicit solitons, singular solitons and periodic singular solutions. The figure 33 represents the character of soliton $u_{1,33}$ and it shows a bell shape soliton when $k = -2$, $\alpha = -2$, $\beta = 2$, $\delta = -2$, $\omega = -2$ within $-3 \leq x, t \leq 3$ and the figure 34 represents, the character of solution $u_{1,34}$ is a singular soliton when $k = -1.5$, $\alpha = -1$, $\beta = 1$, $\delta = -1$, $\omega = -1$ within the plot limit $0 \leq t \leq 3$, $-3 \leq x \leq 3$. Again the solutions $u_{1,35}$ and $u_{1,36}$ are illustrate by the figures 35 and 36 respectively. These figures show that, the solutions are periodic singular solution for $k = 2$, $\alpha = 1$, $\beta = 1$, $\delta = 1$ and $\omega = -1$ within $-8 \leq x, t \leq 8$. Once again, showing the figure 37, the solution $u_{1,37}$ is a bell shape soliton and showing the figure 38, the solution $u_{1,38}$ is a singular bell type soliton for $k = -2$, $\alpha = -2$, $\beta = -2$, $\delta = -2$ and $\omega = -2$ within the plot region $-8 \leq x, t \leq 8$. Yet again, the singular solutions $u_{1,39}$ and $u_{1,40}$ presented by the figures 39 and 40 respectively. Plot of these figures for $k = -2$, $\alpha = -2$, $\beta = 0.45$, $\delta = -1$ and $\omega = -1$ within $-8 \leq x, t \leq 8$ showing the singular periodic solutions.

5.2(f): The Strain Wave Equation in Microstructured Solids

In this sub-section, we have interpreted the characters of the determined solutions to the strain wave equation in microstructured solids for non-dissipative and dissipative cases.

5.2(f)-I: The Non-dissipative Case

We have evaluated various types of solutions $u_{1,41}$ - $u_{1,48}$ to the strain wave equation in microstructured solids for non-dissipative case (4.1.124). In figure 41, we plot the solution $u_{1,41}$ set down in (4.1.135) represents bell shape soliton, when $\varepsilon = 0.1$, $\alpha_1 = 1, \alpha_3 = 1, \alpha_4 = 1.25, \omega = -1.5$ within $-8 \leq x, t \leq 8$ and in figure 42, we plot the solution $u_{1,42}$ set down in (4.1.136) represents singular soliton for $\varepsilon = 0.1, \alpha_1 = -2, \alpha_3 = 2, \alpha_4 = 2, \omega = 1.1$ within $-8 \leq x, t \leq 8$. Again, the solution $u_{1,43}$ set down in (4.1.137) and the solution $u_{1,44}$ set down in (4.1.138) are prevailed by the figures 43 and 44 respectively. These figures shown, the nature of the solutions are periodic singular solutions for $\varepsilon = 0.1, \alpha_1 = 2, \alpha_3 = -2, \alpha_4 = -2$ and $\omega = 2$ within the range $-2 \leq x, t \leq 2$. Moreover, the solution $u_{1,45}$ written down in (4.1.141) carries on the figure 45. This figure found for $\varepsilon = 0.1, \alpha_1 = 2, \alpha_3 = -2, \alpha_4 = -2, \omega = -2$ within $-8 \leq x, t \leq 8$, which represents an anti-bell shape soliton and the soliton $u_{1,46}$ written down in (4.1.142) carry on the figure 46. This figure shows the solution $u_{1,46}$ presents singular anti-bell type soliton for $\varepsilon = 0.1, \alpha_1 = -2, \alpha_3 = -2, \alpha_4 = -2$ and $\omega = -2$ within $-8 \leq x, t \leq 8$. Once more, the solutions $u_{1,47}$ in (4.1.143) and $u_{1,48}$ in (4.1.144) are periodic singular solutions and presented by the figures 47 and 48, respectively for $\varepsilon = 0.1, \alpha_1 = -2, \alpha_3 = -1, \alpha_4 = 1$ and $\omega = 1.25$ within the plot region $-8 \leq x, t \leq 8$.

5.2(f)-II: The Dissipative Case

Herein, we have dealt with different types of evaluated solutions $u_{1,49}$ - $u_{1,50}$ presented in (4.1.156)-(4.1.157) when either $\omega = \pm\theta_1$ or $\omega = \pm\theta_2$ mentioned in subsection 4.2(f)-II and $u_{1,51}$ - $u_{1,52}$ presented in (4.1.160)-(4.1.161) when either $\omega = \pm\vartheta_1$ or $\omega = \pm\vartheta_2$ mentioned in subsection 4.2(f)-II to the strain wave equation in microstructured solids for dissipative case (4.1.145). These solutions associate singular solitons, kink, singular kink. The figures 49-50 plotted for the solution $u_{1,49}$, when $\omega = \pm\theta_1$ within the plot limit $-8 \leq x, t \leq 8$ and the figures 51-52 plotted for the solution $u_{1,49}$, when $\omega = \pm\theta_2$ within the plot limit $0 \leq t \leq 10, -5 \leq x \leq 5$. The character of the solutions $u_{1,49}$ is kink, when $\omega = \pm\theta_1$ either $\omega = \pm\theta_2$ and shown by the figures 49-52, respectively within the area $-25 \leq t \leq 25, -20 \leq x \leq 20$. Also, the solution $u_{1,50}$ is singular, when $\omega = \pm\theta_1$ either $\omega = \pm\theta_2$ and plotted by the figures 53-56, respectively within the area $-25 \leq t \leq 25, -20 \leq x \leq 20$. All of the figures 49-56 are drawn for $\varepsilon = 0.1, \alpha_1 = -2, \alpha_2 = -2, \alpha_3 = -2, \alpha_4 = -2$. On the other hand, the solution $u_{1,51}$ is kink shape soliton, when either $\omega = \pm\vartheta_1$ or $\omega = \pm\vartheta_2$ and illustrated by the figures 57-60, respectively. Moreover, the solution $u_{1,52}$ is singular type solution, when either $\omega = \pm\vartheta_1$ or $\omega = \pm\vartheta_2$ and represented by the figures 61-64, respectively. The figures 57-64 are plotted for $\varepsilon = 0.1, \alpha_1 = 1, \alpha_2 = 1, \alpha_3 = 0.5$ and $\alpha_4 = 1$ within the range $-10 \leq x, t \leq 10$.

Chapter 6

Comparison, Results and Discussion

Preview Material

- 6.1: Comparison between the Obtained Solutions by the MSE Method and the (G'/G) -expansion Method for the KdV Equation
- 6.2: Comparison between the Obtained Solutions by the MSE Method and the (G'/G) -expansion Method for the Boussinesq Equation
- 6.3: Comparison between the Obtained Solutions by the MSE Method and the (G'/G) -expansion Method for the Fifth-order KdV Equation
- 6.4: Comparison between the Obtained Solutions by the MSE Method and the (G'/G) -expansion Method for the Modified Schamel Equation for Acoustic Waves in Plasma Physics
- 6.5: Comparison between the Obtained Solutions by the MSE Method and the (G'/G) -expansion Method for the Modified Kadomtsev-Petviashvili (KP) Equation for Acoustic Waves in Plasma Physics
- 6.6: Comparison between the Obtained Solutions by the MSE Method and the (G'/G) -expansion Method for the Strain Wave Equation in Microstructured Solids for Non-dissipative and Dissipative Cases

In this Chapter, we have compared the exact solitary wave solutions to the NLEEs obtained by the MSE method, when balance number is two over the existing another method, namely, the (G'/G) -expansion method. We observe that the MSE method provides more general and rich exact traveling wave solutions with additional parameters, against the (G'/G) -expansion method.

In view of the fact that the MSE method contains the solution formed (4.1.1) have fully unknown function $\psi(\xi)$ to be determined, but (G'/G) -expansion method contains the solution formed (4.2.1) in which $G(\xi)$ is previously known, i.e. $G(\xi)$ satisfies the ODE $G''(\xi) + \lambda G'(\xi) + \mu G(\xi) = 0$. Thus, the advantages and validity of the MSE method over the (G'/G) -expansion method has been discussed in the following.

6.1: Comparison between the Obtained Solutions by the MSE Method and the (G'/G) -expansion Method for the KdV Equation

Wang et al. (Wang et al., 2008a) proposed the (G'/G) -expansion method and solved the KdV equation. We observe that some of our obtained solutions are identical to the solutions obtained by Wang et al. and some are different. In Table 1, we compare the solutions obtained between the two methods:

Table 1

Solutions obtained by using the (G'/G)-expansion method	Solutions obtained by using the MSE method
i) Since $\omega = \delta\lambda^2 + 8\delta\mu + a_0$, if we select $a_0 = -12\delta\mu$, then the solution $u_{2,1}$ shown in (4.2.12) becomes $u_{2,1}(x, t) = 3\omega \operatorname{sech}^2\left(\frac{\sqrt{\omega}(x - t\omega)}{2\sqrt{\delta}}\right)$	i) The obtained solution $u_{1,1}$ shown in (4.1.17) is $u_{1,1}(x, t) = 3\omega \operatorname{sech}^2\left(\frac{\sqrt{\omega}(x - t\omega)}{2\sqrt{\delta}}\right)$
ii) Since $\omega = \delta\lambda^2 + 8\delta\mu + a_0$, if we select $a_0 = -2\delta(\lambda^2 + 2\mu)$, then the solution $u_{2,2}$ shown in (4.2.13) becomes	ii) Solution $u_{1,5}$ shown in (4.1.23) transform to the trigonometric solution in the subsequent form:

$u_{2,2}(x, t) = \omega \left\{ 2 - 3 \right. \\ \left. \times \sec^2 \left(\frac{\sqrt{\omega}(x - t\omega)}{2\sqrt{\delta}} \right) \right\}$	$u_{1,5}(x, t) = \omega \left\{ 2 - 3 \right. \\ \left. \times \sec^2 \left(\frac{\sqrt{\omega}(x - t\omega)}{2\sqrt{\delta}} \right) \right\}$
<p>iii) Since $\omega = \delta\lambda^2 + 8\delta\mu + a_0$, if we select $a_0 = -12\delta\mu$, then the solution $u_{2,3}$ shown in (4.2.14) becomes</p> $u_{2,3}(x, t) = -3\omega \operatorname{csch}^2 \left(\frac{\sqrt{\omega}(x - t\omega)}{2\sqrt{\delta}} \right)$	<p>iii) The obtained solution $u_{1,2}$ shown in (4.1.18) is</p> $u_{1,2}(x, t) = -3\omega \operatorname{csch}^2 \left(\frac{\sqrt{\omega}(x - t\omega)}{2\sqrt{\delta}} \right)$
<p>iv) Since $\omega = \delta\lambda^2 + 8\delta\mu + a_0$, if we select $a_0 = -2\delta(\lambda^2 + 2\mu)$, then the solution $u_{2,4}$ shown in (4.2.15) becomes</p> $u_{2,4}(x, t) = \omega \left\{ 2 - 3 \right. \\ \left. \times \csc^2 \left(\frac{\sqrt{\omega}(x - t\omega)}{2\sqrt{\delta}} \right) \right\}$	<p>iv) Solution $u_{1,6}$ shown in (4.1.24) transform to the trigonometric solution in the subsequent form:</p> $u_{1,6}(x, t) = \omega \left\{ 2 - 3 \right. \\ \left. \times \csc^2 \left(\frac{\sqrt{\omega}(x - t\omega)}{2\sqrt{\delta}} \right) \right\}$

We have evaluated eight solutions to the KdV equation by using the MSE method. From Table 1, we observed that the solutions $u_{1,1}$, $u_{1,2}$, $u_{1,5}$ and $u_{1,6}$ obtained by the MSE method and the solutions $u_{2,1}$ - $u_{2,4}$ to the KdV equation obtained by the (G'/G) -expansion method are identical.

Wang et al. (Wang et al., 2008a) obtained another solution (4.2.11) called the rational solution, which we did not obtain. But, we have obtained some other important solutions $u_{1,3}$ in (4.1.19), $u_{1,4}$ in (4.1.20), $u_{1,7}$ in (4.1.25) and $u_{1,8}$ in (4.1.26) by the MSE method which are not obtained by Wang et al. Therefore, we might conclude that we have found some solitary solutions are different from Wang et al.

6.2: Comparison between the Obtained Solutions by the MSE Method and the (G'/G) -expansion Method for the Boussinesq Equation

Bekir (Bekir, 2008) employed the (G'/G) -expansion method to solve the Boussinesq equation and constructed some solitary wave solutions. We have compared our solutions with those obtained by Bekir and shown in the subsequent Table 2:

Table 2

Solutions obtained by using the (G'/G) -expansion method	Solutions obtained by using the MSE method
<p>i) Since $\omega = \sqrt{1 - \lambda^2 + 4\mu}$, i.e. $\sqrt{\lambda^2 - 4\mu} = \sqrt{1 - \omega^2}$, then the solution $u_{2,5}$ written down in (4.2.23) turns out to:</p> $u_{2,5}(x, t) = \frac{3}{2}(-1 + \omega^2) \times \operatorname{sech}^2\left(\frac{\sqrt{1 - \omega^2}(x - t\omega)}{2}\right)$	<p>i) Solution $u_{1,9}$ written down in (4.1.37) is</p> $u_{1,9}(x, t) = \frac{3}{2}(-1 + \omega^2) \times \operatorname{sech}^2\left(\frac{\sqrt{1 - \omega^2}(x - t\omega)}{2}\right)$
<p>ii) Solution $u_{2,7}$ written down in (4.2.25) is</p> $u_{2,7}(x, t) = -\frac{3}{2}(\lambda^2 - 4\mu) \times \operatorname{sec}^2\left(\frac{(x - t\omega)\sqrt{4\mu - \lambda^2}}{2}\right)$ <p>where $\omega = \sqrt{1 - \lambda^2 + 4\mu}$.</p>	<p>ii) If we put $\sqrt{\omega^2 - 1} = \sqrt{4\mu - \lambda^2}$, then the hyperbolic solution $u_{1,9}$ written down in (4.1.37) transform to the subsequent trigonometric form:</p> $u_{1,9}(x, t) = -\frac{3}{2}(\lambda^2 - 4\mu) \times \operatorname{sec}^2\left(\frac{\sqrt{4\mu - \lambda^2}}{2}(x - t\omega)\right)$
<p>iii) Since $\omega = \sqrt{1 + \lambda^2 - 4\mu}$, then the solution $u_{2,6}$ written down in (4.2.24) turns out to:</p> $u_{2,6}(x, t) = (\omega^2 - 1) - \frac{3}{2}(\omega^2 - 1) \times \operatorname{sech}^2\left(\frac{(x - t\omega)\sqrt{\omega^2 - 1}}{2}\right)$	<p>iii) Solution $u_{1,13}$ written down in (4.1.43) is</p> $u_{1,13}(x, t) = (\omega^2 - 1) - \frac{3}{2}(\omega^2 - 1) \times \operatorname{sech}^2\left(\frac{(x - t\omega)\sqrt{\omega^2 - 1}}{2}\right)$

<p>iv) Solution $u_{2,8}$ written down in (4.2.26) is</p> $u_{2,8}(x, t) = (\lambda^2 - 4\mu) - \frac{3}{2}(\lambda^2 - 4\mu) \times \sec^2\left(\frac{(x - t\omega)\sqrt{4\mu - \lambda^2}}{2}\right)$ <p>where $\omega = \sqrt{1 + \lambda^2 - 4\mu}$.</p>	<p>iv) If we put $\sqrt{1 - \omega^2} = \sqrt{4\mu - \lambda^2}$, then the hyperbolic solution $u_{1,13}$ written down in (4.1.43) transform to the subsequent trigonometric form:</p> $u_{1,13}(x, t) = (\lambda^2 - 4\mu) - \frac{3}{2}(\lambda^2 - 4\mu) \times \sec^2\left(\frac{(x - t\omega)\sqrt{4\mu - \lambda^2}}{2}\right)$
<p>v) If we put $A = 0, B \neq 0$, then the solution (4.2.17) turns out to:</p> $u(x, t) = -\frac{3}{2}(-1 + \omega^2) \times \operatorname{csch}^2\left(\frac{\sqrt{1 - \omega^2}(x - t\omega)}{2}\right)$ <p>when $\omega = \sqrt{1 - \lambda^2 + 4\mu}$, i.e. $\sqrt{\lambda^2 - 4\mu} = \sqrt{1 - \omega^2}$.</p>	<p>v) Solution $u_{1,10}$ written down in (4.1.38) is</p> $u_{1,10}(x, t) = -\frac{3}{2}(-1 + \omega^2) \times \operatorname{csch}^2\left(\frac{\sqrt{1 - \omega^2}(x - t\omega)}{2}\right)$
<p>vi) If we put $A = 0, B \neq 0$, then the solution (4.2.19) turns out to:</p> $u(x, t) = -\frac{3}{2}(\lambda^2 - 4\mu) \times \csc^2\left(\frac{(x - t\omega)\sqrt{4\mu - \lambda^2}}{2}\right)$ <p>when $\omega = \sqrt{1 - \lambda^2 + 4\mu}$.</p>	<p>vi) If we put $\sqrt{\omega^2 - 1} = \sqrt{4\mu - \lambda^2}$ in $u_{1,10}$, then the hyperbolic solution $u_{1,10}$ written down in (4.1.38) transform to the subsequent trigonometric form:</p> $u_{1,10}(x, t) = -\frac{3}{2}(\lambda^2 - 4\mu) \times \csc^2\left(\frac{(x - t\omega)\sqrt{4\mu - \lambda^2}}{2}\right)$
<p>vii) If we put $A = 0, B \neq 0$, then the solution (4.2.18) turns out to:</p> $u(x, t) = (-1 + \omega^2) + \frac{3(-1 + \omega^2)}{2} \times \operatorname{csch}^2\left(\frac{(x - t\omega)\sqrt{\omega^2 - 1}}{2}\right)$ <p>when $\omega = \sqrt{1 + \lambda^2 - 4\mu}$, i.e. $\sqrt{\lambda^2 - 4\mu} = \sqrt{\omega^2 - 1}$.</p>	<p>vii) Solution $u_{1,14}$ written down in (4.1.44) is</p> $u_{1,14}(x, t) = (-1 + \omega^2) + \frac{3(-1 + \omega^2)}{2} \times \operatorname{csch}^2\left(\frac{(x - t\omega)\sqrt{\omega^2 - 1}}{2}\right)$

<p>viii) If we put $A = 0$, $B \neq 0$, then the solution (4.2.20) turns out to:</p> $u(x, t) = (\lambda^2 - 4\mu) - \frac{3(\lambda^2 - 4\mu)}{2} \times \csc^2 \left(\frac{(x - t\omega)\sqrt{4\mu - \lambda^2}}{2} \right)$ <p>when $\omega = \sqrt{1 + \lambda^2 - 4\mu}$.</p>	<p>viii) If we put $\sqrt{1 - \omega^2} = \sqrt{4\mu - \lambda^2}$ in $u_{1,14}$, then the hyperbolic solution $u_{1,14}$ written down in (4.1.44) transform to the subsequent trigonometric form:</p> $u_{1,14}(x, t) = (\lambda^2 - 4\mu) - \frac{3(\lambda^2 - 4\mu)}{2} \times \csc^2 \left(\frac{(x - t\omega)\sqrt{4\mu - \lambda^2}}{2} \right)$
--	---

We have computed eight solutions to the Boussinesq equation by the MSE method. In the Table 2, we have showed that the solutions $u_{1,9}$, $u_{1,10}$, $u_{1,13}$ and $u_{1,14}$ attained by the MSE method and the solutions $u_{2,5}$ - $u_{2,8}$ and (4.1.17)-(4.1.20) to the Boussinesq equation attained by Bekir through the (G'/G) -expansion method are same.

Bekir (Bekir, 2008) achieved other rational solutions (4.2.21)-(4.2.22), which we did not obtain. But, we have achieved other solutions $u_{1,11}$ set down in (4.1.39), $u_{1,12}$ set down in (4.1.40), $u_{1,15}$ set down in (4.1.45) and $u_{1,16}$ set down in (4.1.46) by the MSE method which are not achieved by Bekir. So, we may say that the MSE method provides some additional solutions.

6.3: Comparison between the Obtained Solutions by the MSE Method and the (G'/G) -expansion Method for the Fifth-order KdV Equation

In this section, we have compared the obtained solutions by the MSE method and the obtained solutions by the (G'/G) -expansion method (Khan and Akbar, 2015c) for the fifth-order KdV equation and shown in the Table 3:

Table 3

Solutions obtained by using the (G'/G)-expansion method	Solutions obtained by using the MSE method
<p>i) If we opt $\alpha = \sqrt{10}(\lambda^2 - 4\mu)$, $\beta = 1$, $\gamma = 0$, $\eta = -1$, then the solution $u_{2,9}$ mentioned in (4.2.31) can be written as</p> $u_{2,9^+}(x, t) = -\frac{3\sqrt{5}}{\sqrt{2}}(\lambda^2 - 4\mu) \times \operatorname{sech}^2\left(\frac{\sqrt{\lambda^2 - 4\mu}(x - t\omega)}{2}\right)$	<p>i) Initially, we replace μ by η and then if we opt $\alpha = \sqrt{10}(\lambda^2 - 4\mu)$, $\beta = 1$, $\gamma = 0$, $\eta = -1$, then the solution $u_{1,21}$ mentioned in (4.1.65) can be written as</p> $u_{1,21}(x, t) = -\frac{3\sqrt{5}}{\sqrt{2}}(\lambda^2 - 4\mu) \times \operatorname{sech}^2\left(\frac{\sqrt{\lambda^2 - 4\mu}(x - t\omega)}{2}\right)$
<p>ii) If we opt $\alpha = \sqrt{10}(\lambda^2 - 4\mu)$, $\beta = 1$, $\gamma = 0$, $\eta = -1$, then the solution $u_{2,10}$ mentioned in (4.2.32) can be written as</p> $u_{2,10^+}(x, t) = -\frac{3\sqrt{5}}{\sqrt{2}}(\lambda^2 - 4\mu) \times \operatorname{sec}^2\left(\frac{(x - t\omega)\sqrt{4\mu - \lambda^2}}{2}\right)$	<p>ii) Initially, we replace μ by η and then if we opt $\alpha = \sqrt{10}(\lambda^2 - 4\mu)$, $\beta = 1$, $\gamma = 0$, $\eta = -1$, then the solution $u_{1,21}$ mentioned in (4.1.65) transform to trigonometric form:</p> $u_{1,21}(x, t) = -\frac{3\sqrt{5}}{\sqrt{2}}(\lambda^2 - 4\mu) \times \operatorname{sec}^2\left(\frac{\sqrt{4\mu - \lambda^2}}{2}(x - t\omega)\right)$
<p>iii) If we opt $\alpha = -\sqrt{10}(\lambda^2 - 4\mu)$, $\beta = 1$, $\gamma = 0$, $\eta = -1$, then the solution $u_{2,9}$ mentioned in (4.2.31) can be written as</p> $u_{2,9^-}(x, t) = \frac{3\sqrt{5}}{\sqrt{2}}(\lambda^2 - 4\mu) \times \operatorname{sech}^2\left(\frac{(x - t\omega)\sqrt{\lambda^2 - 4\mu}}{2}\right)$	<p>iii) First, we replace μ by η and then if we opt $\alpha = -\sqrt{10}(\lambda^2 - 4\mu)$, $\beta = 1$, $\gamma = 0$, $\eta = -1$, then the solution $u_{1,17}$ mentioned in (4.1.59) can be written as</p> $u_{1,17}(x, t) = \frac{3\sqrt{5}}{\sqrt{2}}(\lambda^2 - 4\mu) \times \operatorname{sech}^2\left(\frac{(x - t\omega)\sqrt{\lambda^2 - 4\mu}}{2}\right)$
<p>iv) If we opt $\alpha = -\sqrt{10}(\lambda^2 - 4\mu)$, $\beta = 1$, $\gamma = 0$, $\eta = -1$, then the solution $u_{2,10}$ mentioned in (4.2.32) can be written as</p> $u_{2,10^-}(x, t) = \frac{3\sqrt{5}}{\sqrt{2}}(\lambda^2 - 4\mu) \times \operatorname{sec}^2\left(\frac{(x - t\omega)\sqrt{4\mu - \lambda^2}}{2}\right)$	<p>iv) First, we replace μ by η and then if we opt $\alpha = -\sqrt{10}(\lambda^2 - 4\mu)$, $\beta = 1$, $\gamma = 0$, $\eta = -1$, then the solution $u_{1,17}$ mentioned in (4.1.59) transform to trigonometric form:</p> $u_{1,17}(x, t) = \frac{3\sqrt{5}}{\sqrt{2}}(\lambda^2 - 4\mu) \times \operatorname{sec}^2\left(\frac{(x - t\omega)\sqrt{4\mu - \lambda^2}}{2}\right)$

<p>v) If we opt $\alpha = \sqrt{10}(\lambda^2 - 4\mu)$, $\beta = 1$, $\gamma = 0$, $\eta = -1$, then the solution $u_{2,11}$ mentioned in (4.2.33) can be written as</p> $u_{1,11^+}(x, t) = \frac{3\sqrt{5}}{\sqrt{2}}(\lambda^2 - 4\mu) \times \operatorname{csch}^2\left(\frac{\sqrt{\lambda^2 - 4\mu}(x - t\omega)}{2}\right)$	<p>v) Initially, we replace μ by η and then if we opt $\alpha = \sqrt{10}(\lambda^2 - 4\mu)$, $\beta = 1$, $\gamma = 0$, $\eta = -1$, then the solution $u_{1,22}$ mentioned in (4.1.66) can be written as</p> $u_{1,22}(x, t) = \frac{3\sqrt{5}}{\sqrt{2}}(\lambda^2 - 4\mu) \times \operatorname{csch}^2\left(\frac{\sqrt{\lambda^2 - 4\mu}(x - t\omega)}{2}\right)$
<p>vi) If we opt $\alpha = \sqrt{10}(\lambda^2 - 4\mu)$, $\beta = 1$, $\gamma = 0$, $\eta = -1$, then the solution $u_{2,12}$ mentioned in (4.2.34) can be written as</p> $u_{1,12^+}(x, t) = -\frac{3\sqrt{5}}{\sqrt{2}}(\lambda^2 - 4\mu) \times \operatorname{csc}^2\left(\frac{(x - t\omega)\sqrt{4\mu - \lambda^2}}{2}\right)$	<p>vi) Initially, we replace μ by η and then if we opt $\alpha = \sqrt{10}(\lambda^2 - 4\mu)$, $\beta = 1$, $\gamma = 0$, $\eta = -1$, then the solution $u_{1,22}$ mentioned in (4.1.66) transform to trigonometric form:</p> $u_{1,22}(x, t) = -\frac{3\sqrt{5}}{\sqrt{2}}(\lambda^2 - 4\mu) \times \operatorname{csc}^2\left(\frac{(x - t\omega)\sqrt{4\mu - \lambda^2}}{2}\right)$
<p>vii) If we opt $\alpha = -\sqrt{10}(\lambda^2 - 4\mu)$, $\beta = 1$, $\gamma = 0$, $\eta = -1$, then the solution $u_{2,11}$ mentioned in (4.2.33) can be written as</p> $u_{1,11^-}(x, t) = -\frac{3\sqrt{5}}{\sqrt{2}}(\lambda^2 - 4\mu) \times \operatorname{csch}^2\left(\frac{(x - t\omega)\sqrt{\lambda^2 - 4\mu}}{2}\right)$	<p>vii) At first, we replace μ by η and then if we opt $\alpha = -\sqrt{10}(\lambda^2 - 4\mu)$, $\beta = 1$, $\gamma = 0$, $\eta = -1$, then the solution $u_{1,18}$ mentioned in (4.1.60) can be written as</p> $u_{1,18}(x, t) = -\frac{3\sqrt{5}}{\sqrt{2}}(\lambda^2 - 4\mu) \times \operatorname{csch}^2\left(\frac{(x - t\omega)\sqrt{\lambda^2 - 4\mu}}{2}\right)$
<p>viii) If we opt $\alpha = -\sqrt{10}(\lambda^2 - 4\mu)$, $\beta = 1$, $\gamma = 0$, $\eta = -1$, then the solution $u_{2,12}$ mentioned in (4.2.34) can be written as</p> $u_{1,12^-}(x, t) = \frac{3\sqrt{5}}{\sqrt{2}}(\lambda^2 - 4\mu) \times \operatorname{csc}^2\left(\frac{(x - t\omega)\sqrt{4\mu - \lambda^2}}{2}\right)$	<p>viii) At first, we replace μ by η and then if we opt $\alpha = -\sqrt{10}(\lambda^2 - 4\mu)$, $\beta = 1$, $\gamma = 0$, $\eta = -1$, then the solution $u_{1,18}$ mentioned in (4.1.60) transform to trigonometric form:</p> $u_{1,18}(x, t) = \frac{3\sqrt{5}}{\sqrt{2}}(\lambda^2 - 4\mu) \times \operatorname{csc}^2\left(\frac{(x - t\omega)\sqrt{4\mu - \lambda^2}}{2}\right)$

In Table 3, we have showed that the solutions $u_{1,17}$, $u_{1,18}$, $u_{1,21}$ and $u_{1,22}$ found through the MSE method and the solutions $u_{2,9}$ - $u_{2,12}$ found through the (G'/G) -expansion method (Khan and Akbar, 2015c) are in matching, for the fifth-order KdV equation.

By using the (G'/G) -expansion method, Khan and Akbar (Khan and Akbar, 2015c) found another solution (4.2.30), which we did not find through the MSE method. But, using the MSE method, we found other solutions $u_{1,19}$ in (4.1.61), $u_{1,20}$ in (4.1.62), $u_{1,23}$ in (4.1.67) and $u_{1,24}$ in (4.1.68), which are not found by the (G'/G) -expansion method. So, we found some fresh solitary wave solutions by the MSE method.

6.4: Comparison between the Obtained Solutions by the MSE Method and the (G'/G) -expansion Method for the Modified Schamel Equation for Acoustic Waves in Plasma Physics

Taha et al. (Taha et al., 2013) got some solutions to the modified Schamel equation for acoustic waves in plasma physics by using the (G'/G) -expansion method and we got some solutions to the modified Schamel equation by using MSE method, which are identical as shown in the Table 4:

Table 4

Solutions evaluated by the (G'/G) -expansion method	Solutions evaluated by the MSE method
<p>i) Since $\omega = 4k^3\delta(\lambda^2 - 4\mu)$,</p> <p>i.e. $\sqrt{\lambda^2 - 4\mu} = \frac{1}{2}\sqrt{\frac{\omega}{k^3\delta}}$, then the solution $u_{2,13}$ shown in (4.2.45) can be written in the form:</p> $u_{2,13}(x, t) = \frac{225\omega^2}{64k^2} \operatorname{sech}^4 \left(\frac{\sqrt{\omega}(kx - t\omega)}{4k^{\frac{3}{2}}\sqrt{\delta}} \right)$	<p>i) The obtained solution $u_{1,25}$ shown in (4.1.85) is</p> $u_{1,25}(x, t) = \frac{225\omega^2}{64k^2} \operatorname{sech}^4 \left(\frac{\sqrt{\omega}(kx - t\omega)}{4k^{\frac{3}{2}}\sqrt{\delta}} \right)$

<p>ii) Since $\omega = 4k^3\delta(\lambda^2 - 4\mu)$, then the solution $u_{2,14}$ shown in (4.2.46) can be written in the form:</p> $u_{2,14}(x, t) = \frac{225\omega^2}{64k^2} \times \sec^4\left(\frac{\sqrt{4\mu - \lambda^2}(kx - t\omega)}{2}\right)$	<p>ii) If we choose $\frac{1}{2}\sqrt{\frac{\omega}{k^3\delta}} = \sqrt{-(4\mu - \lambda^2)}$, then the solution $u_{1,25}$ shown in (4.1.85) can be written in the form:</p> $u_{1,25}(x, t) = \frac{225\omega^2}{64k^2} \times \sec^4\left(\frac{\sqrt{4\mu - \lambda^2}(kx - t\omega)}{2}\right)$
<p>iii) Since $\omega = 4k^3\delta(\lambda^2 - 4\mu)$, i.e. $\sqrt{\lambda^2 - 4\mu} = \frac{1}{2}\sqrt{\frac{\omega}{k^3\delta}}$, then the solution $u_{2,15}$ shown in (4.2.47) can be written in the form:</p> $u_{2,15}(x, t) = \frac{225\omega^2}{64k^2} \operatorname{csch}^4\left(\frac{\sqrt{\omega}(kx - t\omega)}{4k^2\sqrt[3]{\delta}}\right)$	<p>iii) The obtained solution $u_{1,26}$ shown in (4.1.86) is</p> $u_{1,26}(x, t) = \frac{225\omega^2}{64k^2} \operatorname{csch}^4\left(\frac{\sqrt{\omega}(kx - t\omega)}{4k^2\sqrt[3]{\delta}}\right)$
<p>iv) Since $\omega = 4k^3\delta(\lambda^2 - 4\mu)$, then the solution $u_{2,16}$ in (4.2.48) can be written in the form:</p> $u_{2,16}(x, t) = \frac{225\omega^2}{64k^2} \times \csc^4\left(\frac{\sqrt{4\mu - \lambda^2}(kx - t\omega)}{2}\right)$	<p>iv) If we choose $\frac{1}{2}\sqrt{\frac{\omega}{k^3\delta}} = \sqrt{-(4\mu - \lambda^2)}$, then the solution $u_{1,26}$ in (4.1.86) can be written in the form:</p> $u_{1,26}(x, t) = \frac{225\omega^2}{64k^2} \times \csc^4\left(\frac{\sqrt{4\mu - \lambda^2}(kx - t\omega)}{2}\right)$

From Table 4, we see that the solutions $u_{1,25}$ and $u_{1,26}$ evaluated by the MSE method and the solutions $u_{2,13}$ - $u_{2,16}$ derived by Taha et al. to the modified Schamel equation by the (G'/G) -expansion method are indistinguishable.

Taha et al. (Taha et al., 2013) evaluated other solution (4.2.44) by the (G'/G) -expansion method, which we did not evaluate by the MSE method. But, we derived other solutions $u_{1,27}$ - $u_{1,32}$ by the MSE method, which are not found by Taha et al. We have evaluated some other hyperbolic and trigonometric solutions by the MSE method which are different from the solutions obtained by the (G'/G) -expansion method.

6.5: Comparison between the Obtained Solutions by the MSE Method and the (G'/G) -expansion Method for the Modified Kadomtsev-Petviashvili (KP) Equation for Acoustic Waves in Plasma Physics

Taha et al. (Taha et al., 2013) introduced some solitary solutions to the modified KP equation for acoustic waves in plasma physics via the (G'/G) -expansion method and we have derived some solitary solutions to the same equation via the MSE method. The comparison among these solutions is shown in the Table 5:

Table 5

Solutions examined by the (G'/G) -expansion method	Solutions examined by the MSE method
<p>i) Solution $u_{2,17}$ in (4.2.64) is</p> $u_{2,17}(x, y, t) = \frac{225\beta^2(\lambda^2 - 4\mu)^2}{4\alpha^2} \times \operatorname{sech}^4\left(\frac{\sqrt{\lambda^2 - 4\mu}(x + ky - \omega t)}{2}\right),$ <p>where $\omega = k^2\delta + 4\beta\lambda^2 - 16\beta\mu$.</p>	<p>i) If we set $\omega = k^2\delta + 4\beta\lambda^2 - 16\beta\mu$, then the solution $u_{1,33}$ in (4.1.112), we have</p> $u_{1,33}(x, y, t) = \frac{225\beta^2(\lambda^2 - 4\mu)^2}{4\alpha^2} \times \operatorname{sech}^4\left(\frac{\sqrt{\lambda^2 - 4\mu}(x + ky - \omega t)}{2}\right)$
<p>ii) Solution $u_{2,18}$ in (4.2.65) is</p> $u_{2,18}(x, y, t) = \frac{225\beta^2(\lambda^2 - 4\mu)^2}{4\alpha^2} \times \operatorname{sec}^4\left(\frac{(x + ky - \omega t)\sqrt{4\mu - \lambda^2}}{2}\right),$ <p>where $\omega = k^2\delta + 4\beta\lambda^2 - 16\beta\mu$.</p>	<p>ii) If we set $\omega = k^2\delta + 4\beta\lambda^2 - 16\beta\mu$, then the solution $u_{1,33}$ in (4.1.112) reduces in the subsequent trigonometric form:</p> $u_{1,33}(x, y, t) = \frac{225\beta^2(\lambda^2 - 4\mu)^2}{4\alpha^2} \times \operatorname{sec}^4\left(\frac{(x + ky - \omega t)\sqrt{4\mu - \lambda^2}}{2}\right)$
<p>iii) Solution $u_{2,19}$ in (4.2.66) is</p> $u_{2,19}(x, y, t) = \frac{25\beta^2(\lambda^2 - 4\mu)^2}{4\alpha^2} \times \left\{1 - 3 \tanh^2\left(\frac{(x + ky - \omega t)\sqrt{\lambda^2 - 4\mu}}{2}\right)\right\}^2,$ <p>where $\omega = k^2\delta + 4\beta\lambda^2 - 16\beta\mu$.</p>	<p>iii) If we set $\omega = k^2\delta + 4\beta\lambda^2 - 16\beta\mu$, then the solution $u_{1,37}$ in (4.1.119), we have</p> $u_{1,37}(x, y, t) = \frac{25\beta^2(\lambda^2 - 4\mu)^2}{4\alpha^2} \times \left\{1 - 3 \tanh^2\left(\frac{(x + ky - \omega t)\sqrt{\lambda^2 - 4\mu}}{2}\right)\right\}^2$

<p>iv) Solution $u_{2,20}$ in (4.2.67) is</p> $u_{2,20}(x, y, t) = \frac{25\beta^2(\lambda^2 - 4\mu)^2}{4\alpha^2} \times$ $\left\{ 1 + 3 \tan^2 \left(\frac{(x + ky - \omega t)\sqrt{4\mu - \lambda^2}}{2} \right) \right\}^2,$ <p>where $\omega = k^2\delta + 4\beta\lambda^2 - 16\beta\mu$.</p>	<p>iv) If we set $\omega = k^2\delta + 4\beta\lambda^2 - 16\beta\mu$, then the solution $u_{1,37}$ in (4.1.119) reduces in the subsequent trigonometric form:</p> $u_{1,37}(x, y, t) = \frac{25\beta^2(\lambda^2 - 4\mu)^2}{4\alpha^2} \times$ $\left\{ 1 + 3 \tan^2 \left(\frac{(x + ky - \omega t)\sqrt{4\mu - \lambda^2}}{2} \right) \right\}^2$
<p>v) Solution $u_{2,21}$ in (4.2.68) is</p> $u_{2,21}(x, y, t) = \frac{225\beta^2(\lambda^2 - 4\mu)^2}{4\alpha^2} \times$ $\operatorname{csch}^4 \left(\frac{(x + ky - \omega t)\sqrt{\lambda^2 - 4\mu}}{2} \right),$ <p>where $\omega = k^2\delta - 4\beta\lambda^2 + 16\beta\mu$.</p>	<p>v) If we set $\omega = k^2\delta - 4\beta\lambda^2 + 16\beta\mu$, then the solution $u_{1,34}$ in (4.1.113), we have</p> $u_{1,34}(x, y, t) = \frac{225\beta^2(\lambda^2 - 4\mu)^2}{4\alpha^2} \times$ $\operatorname{csch}^4 \left(\frac{(x + ky - \omega t)\sqrt{\lambda^2 - 4\mu}}{2} \right)$
<p>vi) Solution $u_{2,22}$ in (4.2.69) is</p> $u_{2,22}(x, y, t) = \frac{225\beta^2(\lambda^2 - 4\mu)^2}{4\alpha^2} \times$ $\operatorname{csc}^4 \left(\frac{(x + ky - \omega t)\sqrt{4\mu - \lambda^2}}{2} \right),$ <p>where $\omega = k^2\delta - 4\beta\lambda^2 + 16\beta\mu$.</p>	<p>vi) If we set $\omega = k^2\delta - 4\beta\lambda^2 + 16\beta\mu$, then the solution $u_{1,34}$ in (4.1.113) reduces in the subsequent trigonometric form:</p> $u_{1,34}(x, y, t) = \frac{225\beta^2(\lambda^2 - 4\mu)^2}{4\alpha^2} \times$ $\operatorname{csc}^4 \left(\frac{(x + ky - \omega t)\sqrt{4\mu - \lambda^2}}{2} \right)$
<p>vii) Solution $u_{2,23}$ in (4.2.70) is</p> $u_{2,23}(x, y, t) = \frac{25\beta^2(\lambda^2 - 4\mu)^2}{4\alpha^2} \times$ $\left\{ 2 + 3\operatorname{csch}^2 \left(\frac{(x + ky - \omega t)\sqrt{\lambda^2 - 4\mu}}{2} \right) \right\}^2,$ <p>where $\omega = k^2\delta - 4\beta\lambda^2 + 16\beta\mu$.</p>	<p>vii) If we set $\omega = k^2\delta - 4\beta\lambda^2 + 16\beta\mu$, then the solution $u_{1,38}$ in (4.1.120), we have</p> $u_{1,38}(x, y, t) = \frac{25\beta^2(\lambda^2 - 4\mu)^2}{4\alpha^2} \times$ $\left\{ 2 + 3\operatorname{csch}^2 \left(\frac{(x + ky - \omega t)\sqrt{\lambda^2 - 4\mu}}{2} \right) \right\}^2$
<p>viii) Solution $u_{2,24}$ in (4.2.71) is</p> $u_{2,24}(x, y, t) = \frac{25\beta^2(\lambda^2 - 4\mu)^2}{4\alpha^2} \times$ $\left\{ -2 + 3\operatorname{csc}^2 \left(\frac{(x + ky - \omega t)\sqrt{4\mu - \lambda^2}}{2} \right) \right\}^2,$ <p>where $\omega = k^2\delta - 4\beta\lambda^2 + 16\beta\mu$.</p>	<p>viii) If we set $\omega = k^2\delta - 4\beta\lambda^2 + 16\beta\mu$, then the solution $u_{1,38}$ in (4.1.120) reduces in the subsequent trigonometric form:</p> $u_{1,38}(x, y, t) = \frac{25\beta^2(\lambda^2 - 4\mu)^2}{4\alpha^2} \times$ $\left\{ -2 + 3\operatorname{csc}^2 \left(\frac{(x + ky - \omega t)\sqrt{4\mu - \lambda^2}}{2} \right) \right\}^2$

From Table 5, we observed that, our obtained solutions $u_{1,33}$, $u_{1,34}$, $u_{1,37}$ and $u_{1,38}$ via the MSE method and Taha et al.'s obtained solutions $u_{2,17}$ - $u_{2,24}$ to the modified KP equation via the (G'/G) -expansion method are one and the same.

Also Taha et al. (Taha et al., 2013) obtained other solutions (4.2.60) and (4.2.63) by the (G'/G) -expansion method, which we did not obtain by the MSE method. On the other hand, we have obtained another solutions $u_{1,35}$, $u_{1,36}$, $u_{1,39}$ and $u_{1,40}$ via the MSE method, which are not obtained by Taha et al. Thus, we have obtained some hyperbolic and trigonometric solitary solutions by the MSE method which are different from the solutions obtained by the (G'/G) -expansion method.

6.6: Comparison between the Obtained Solutions by the MSE Method and the (G'/G) -expansion Method for the Strain Wave Equation in Microstructured Solids for Non-dissipative and Dissipative Cases

In this section, we have compared the required solutions through the MSE method and the solutions through the (G'/G) -expansion method (Khan and Akbar, 2015c) for the strain wave equation in microstructured solids for non-dissipative and dissipative cases respectively, which are shown in the subsequent Table 6 for non-dissipative case and Table 7 for dissipative case.

Table 6: For Non-dissipative Case

Solutions examined by the (G'/G) -expansion method	Solutions examined by the MSE method
<p>i) Since $\omega = \pm \frac{\sqrt{1+\varepsilon\lambda^2\alpha_3-4\varepsilon\mu\alpha_3}}{\sqrt{1+\varepsilon\lambda^2\alpha_4-4\varepsilon\mu\alpha_4}}$, then the solution $u_{2,25}$ set down in (4.2.82) can be written in the following form:</p> $u_{2,25}(x, t) = \frac{(-1 + \omega^2)}{\varepsilon\alpha_1} - \frac{3(-1 + \omega^2)}{2\varepsilon\alpha_1} \times \operatorname{sech}^2\left(\frac{(x - t\omega)\sqrt{\omega^2 - 1}}{2\sqrt{\varepsilon}\sqrt{\alpha_3 - \omega^2\alpha_4}}\right)$	<p>i) The solution $u_{1,45}$ set down in (4.1.141) is</p> $u_{1,45}(x, y, t) = \frac{(-1 + \omega^2)}{\varepsilon\alpha_1} - \frac{3(-1 + \omega^2)}{2\varepsilon\alpha_1} \times \operatorname{sech}^2\left(\frac{(x - t\omega)\sqrt{\omega^2 - 1}}{2\sqrt{\varepsilon}\sqrt{\alpha_3 - \omega^2\alpha_4}}\right)$

<p>ii) Since $\omega = \pm \frac{\sqrt{1+\varepsilon\lambda^2\alpha_3-4\varepsilon\mu\alpha_3}}{\sqrt{1+\varepsilon\lambda^2\alpha_4-4\varepsilon\mu\alpha_4}}$,</p> <p>i.e. $\sqrt{1-\omega^2} = \sqrt{-\frac{\varepsilon(\lambda^2-4\mu)(\alpha_3-\alpha_4)}{1+\varepsilon(\lambda^2-4\mu)\alpha_4}}$, then the solution $u_{2,26}$ set down in (4.2.83) can be written in the following form:</p> $u_{2,26}(x, t) = \frac{(-1 + \omega^2)}{\varepsilon\alpha_1} - \frac{3(-1 + \omega^2)}{2\varepsilon\alpha_1} \times \sec^2\left(\frac{(x - t\omega)\sqrt{1 - \omega^2}}{2\sqrt{\varepsilon}\sqrt{\alpha_3 - \omega^2\alpha_4}}\right)$	<p>ii) Solution $u_{1,45}$ set down in (4.1.141) transform to trigonometric as follows:</p> $u_{1,45}(x, y, t) = \frac{(-1 + \omega^2)}{\varepsilon\alpha_1} - \frac{3(-1 + \omega^2)}{2\varepsilon\alpha_1} \times \sec^2\left(\frac{(x - t\omega)\sqrt{1 - \omega^2}}{2\sqrt{\varepsilon}\sqrt{\alpha_3 - \omega^2\alpha_4}}\right)$
<p>iii) Since $\omega = \pm \frac{\sqrt{-1+\varepsilon\lambda^2\alpha_3-4\varepsilon\mu\alpha_3}}{\sqrt{-1+\varepsilon\lambda^2\alpha_4-4\varepsilon\mu\alpha_4}}$,</p> <p>i.e. $\sqrt{\omega^2 - 1} = \sqrt{\frac{\varepsilon(\lambda^2-4\mu)(\alpha_3-\alpha_4)}{-1+\varepsilon(\lambda^2-4\mu)\alpha_4}}$, then the solution $u_{2,27}$ set down in (4.2.84) can be written in the following form:</p> $u_{2,27}(x, t) = \frac{3(-1 + \omega^2)}{2\varepsilon\alpha_1} \times \operatorname{sech}^2\left(\frac{(x - t\omega)\sqrt{\omega^2 - 1}}{2\sqrt{\varepsilon}\sqrt{-\alpha_3 + \omega^2\alpha_4}}\right)$	<p>iii) Solution $u_{1,41}$ set down in (4.1.135) is</p> $u_{1,41}(x, y, t) = \frac{3(-1 + \omega^2)}{2\varepsilon\alpha_1} \times \operatorname{sech}^2\left(\frac{(x - t\omega)\sqrt{\omega^2 - 1}}{2\sqrt{\varepsilon}\sqrt{-\alpha_3 + \omega^2\alpha_4}}\right)$
<p>iv) Since $\omega = \pm \frac{\sqrt{-1+\varepsilon\lambda^2\alpha_3-4\varepsilon\mu\alpha_3}}{\sqrt{-1+\varepsilon\lambda^2\alpha_4-4\varepsilon\mu\alpha_4}}$,</p> <p>i.e. $\sqrt{1-\omega^2} = \sqrt{-\frac{\varepsilon(\lambda^2-4\mu)(\alpha_3-\alpha_4)}{-1+\varepsilon(\lambda^2-4\mu)\alpha_4}}$, then the solution $u_{2,28}$ set down in (4.2.85) can be written in the following form:</p> $u_{2,28}(x, t) = \frac{3(-1 + \omega^2)}{2\varepsilon\alpha_1} \times \sec^2\left(\frac{(x - t\omega)\sqrt{1 - \omega^2}}{2\sqrt{\varepsilon}\sqrt{-\alpha_3 + \omega^2\alpha_4}}\right)$	<p>iv) Solution $u_{1,41}$ set down in (4.1.135) transform to trigonometric as follows:</p> $u_{1,41}(x, y, t) = \frac{3(-1 + \omega^2)}{2\varepsilon\alpha_1} \times \sec^2\left(\frac{(x - t\omega)\sqrt{1 - \omega^2}}{2\sqrt{\varepsilon}\sqrt{-\alpha_3 + \omega^2\alpha_4}}\right)$
<p>v) Since $\omega = \pm \frac{\sqrt{1+\varepsilon\lambda^2\alpha_3-4\varepsilon\mu\alpha_3}}{\sqrt{1+\varepsilon\lambda^2\alpha_4-4\varepsilon\mu\alpha_4}}$, then the solution $u_{2,29}$ set down in (4.2.86) can be written in the following form:</p> $u_{2,29}(x, t) = \frac{(-1 + \omega^2)}{\varepsilon\alpha_1} + \frac{3(-1 + \omega^2)}{2\varepsilon\alpha_1} \times \operatorname{csch}^2\left(\frac{(x - t\omega)\sqrt{\omega^2 - 1}}{2\sqrt{\varepsilon}\sqrt{\alpha_3 - \omega^2\alpha_4}}\right)$	<p>v) Solution $u_{1,46}$ set down in (4.1.142) is</p> $u_{1,46}(x, y, t) = \frac{(-1 + \omega^2)}{\varepsilon\alpha_1} + \frac{3(-1 + \omega^2)}{2\varepsilon\alpha_1} \times \operatorname{csch}^2\left(\frac{(x - t\omega)\sqrt{\omega^2 - 1}}{2\sqrt{\varepsilon}\sqrt{\alpha_3 - \omega^2\alpha_4}}\right)$

<p>vi) Since $\omega = \pm \frac{\sqrt{1+\varepsilon\lambda^2\alpha_3-4\varepsilon\mu\alpha_3}}{\sqrt{1+\varepsilon\lambda^2\alpha_4-4\varepsilon\mu\alpha_4}}$, then the solution $u_{2,30}$ set down in (4.2.87) can be written in the following form:</p> $u_{2,30}(x, t) = \frac{(-1 + \omega^2)}{\varepsilon\alpha_1} - \frac{3(-1 + \omega^2)}{2\varepsilon\alpha_1} \times \text{csc}^2\left(\frac{(x - t\omega)\sqrt{1 - \omega^2}}{2\sqrt{\varepsilon}\sqrt{\alpha_3 - \omega^2\alpha_4}}\right)$	<p>vi) Solution $u_{1,46}$ set down in (4.1.142) transform to trigonometric as follows:</p> $u_{1,46}(x, y, t) = \frac{(-1 + \omega^2)}{\varepsilon\alpha_1} - \frac{3(-1 + \omega^2)}{2\varepsilon\alpha_1} \times \text{csc}^2\left(\frac{(x - t\omega)\sqrt{1 - \omega^2}}{2\sqrt{\varepsilon}\sqrt{\alpha_3 - \omega^2\alpha_4}}\right)$
<p>vii) Since $\omega = \pm \frac{\sqrt{-1+\varepsilon\lambda^2\alpha_3-4\varepsilon\mu\alpha_3}}{\sqrt{-1+\varepsilon\lambda^2\alpha_4-4\varepsilon\mu\alpha_4}}$, then the solution $u_{2,31}$ set down in (4.2.88) can be written in the following form:</p> $u_{2,31}(x, t) = -\frac{3(-1 + \omega^2)}{2\varepsilon\alpha_1} \times \text{csch}^2\left(\frac{(x - t\omega)\sqrt{\omega^2 - 1}}{2\sqrt{\varepsilon}\sqrt{-\alpha_3 + \omega^2\alpha_4}}\right)$	<p>vii) Solution $u_{1,42}$ set down in (4.1.136) is</p> $u_{1,42}(x, y, t) = -\frac{3(-1 + \omega^2)}{2\varepsilon\alpha_1} \times \text{csch}^2\left(\frac{(x - t\omega)\sqrt{\omega^2 - 1}}{2\sqrt{\varepsilon}\sqrt{-\alpha_3 + \omega^2\alpha_4}}\right)$
<p>viii) Since $\omega = \pm \frac{\sqrt{-1+\varepsilon\lambda^2\alpha_3-4\varepsilon\mu\alpha_3}}{\sqrt{-1+\varepsilon\lambda^2\alpha_4-4\varepsilon\mu\alpha_4}}$, then the solution $u_{2,32}$ set down in (4.2.89) can be written in the following form:</p> $u_{2,32}(x, t) = \frac{3(-1 + \omega^2)}{2\varepsilon\alpha_1} \times \text{csch}^2\left(\frac{(x - t\omega)\sqrt{1 - \omega^2}}{2\sqrt{\varepsilon}\sqrt{-\alpha_3 + \omega^2\alpha_4}}\right)$	<p>viii) Solution $u_{1,42}$ set down in (4.1.136) transform to trigonometric as follows:</p> $u_{1,42}(x, y, t) = \frac{3(-1 + \omega^2)}{2\varepsilon\alpha_1} \times \text{csch}^2\left(\frac{(x - t\omega)\sqrt{1 - \omega^2}}{2\sqrt{\varepsilon}\sqrt{-\alpha_3 + \omega^2\alpha_4}}\right)$

Table 7: For Dissipative Case

Solutions examined by the (G'/G) -expansion method	Solutions examined by the MSE method
<p>i) If we choose $\sqrt{\lambda^2 - 4\mu} = \frac{\alpha_2\omega}{5(\alpha_3 - \omega^2\alpha_4)}$ and $\varepsilon = \frac{-1+\omega^2}{6(\lambda^2-4\mu)(\alpha_3-\omega^2\alpha_4)}$, then the solution $u_{2,33}$ shown in (4.2.95) can be derived in the subsequent form:</p> $u_{2,33}(x, t) = \frac{3\omega^2\alpha_2^2}{50\alpha_1(\alpha_3 - \omega^2\alpha_4)} \times \left\{1 + \tanh\left(\frac{\omega(-x + t\omega)\alpha_2}{10(\alpha_3 - \omega^2\alpha_4)}\right)\right\}^2$	<p>i) Solution $u_{1,49}$ shown in (4.1.156) is</p> $u_{1,49}(x, t) = \frac{3\omega^2\alpha_2^2}{50\alpha_1(\alpha_3 - \omega^2\alpha_4)} \times \left\{1 + \tanh\left(\frac{\omega(-x + t\omega)\alpha_2}{10(\alpha_3 - \omega^2\alpha_4)}\right)\right\}^2$

<p>ii) If we choose $\sqrt{\lambda^2 - 4\mu} = \frac{\alpha_2\omega}{5(\alpha_3 - \omega^2\alpha_4)}$ and $\varepsilon = \frac{-1+\omega^2}{6(\lambda^2-4\mu)(\alpha_3-\omega^2\alpha_4)}$, then the solution $u_{2,35}$ shown in (4.2.97) can be derived in the subsequent form:</p> $u_{2,35}(x, t) = \frac{3\omega^2\alpha_2^2}{50\alpha_1(\alpha_3 - \omega^2\alpha_4)} \times \left\{ 1 + \coth\left(\frac{\omega(-x + t\omega)\alpha_2}{10(\alpha_3 - \omega^2\alpha_4)}\right) \right\}^2$	<p>ii) Solution $u_{1,50}$ shown in (4.1.157) is</p> $u_{1,50}(x, t) = \frac{3\omega^2\alpha_2^2}{50\alpha_1(\alpha_3 - \omega^2\alpha_4)} \times \left\{ 1 + \coth\left(\frac{\omega(-x + t\omega)\alpha_2}{10(\alpha_3 - \omega^2\alpha_4)}\right) \right\}^2$
--	---

Through the MSE method, we have examined some solitary wave solutions to the strain wave equation for non-dissipative and dissipative cases. In Table 6, we have described that the solutions $u_{1,41}$, $u_{1,42}$, $u_{1,45}$, $u_{1,46}$ for non-dissipative case and in Table 7, the solutions $u_{1,49}$, $u_{1,50}$ for dissipative case evaluated via MSE method and the solutions $u_{2,25}$ - $u_{2,32}$ for non-dissipative case and the solutions $u_{2,33}$, $u_{2,35}$ for dissipative case evaluated through the (G'/G) -expansion method (Khan and Akbar, 2015c) are indistinguishable.

By the (G'/G) -expansion method, Khan and Akbar (Khan and Akbar, 2015c) found another solutions (4.2.77), (4.2.81) for non-dissipative case and the solutions $u_{2,34}$, $u_{2,36}$ and (4.2.94) for dissipative case, which we did not find through the MSE method. However, we have achieved another solutions $u_{1,43}$, $u_{1,44}$, $u_{1,47}$, $u_{1,48}$ for non-dissipative case and the solutions $u_{1,51}$, $u_{1,52}$ for dissipative case by the MSE method, which are not obtained by the (G'/G) -expansion method. Therefore, we might say that some of the obtained solitary solutions by the MSE method is different from the (G'/G) -expansion method.

From the above comparisons, we observe that, we derived some important solitary wave solutions by the MSE method, which are not found by the (G'/G) -expansion method. Also, we see that the solutions attained by the MSE method are more general and the solutions found by the (G'/G) -expansion method are only special case. Therefore, we may conclude that the MSE method is useful, competent and effective method in solving NLEEs in applied mathematics, mathematical physics, plasma physics and engineering.

Chapter 7

Conclusion and Future Instructions

In this dissertation, by using the MSE method, we have established a procedure to examine the exact solitary wave solutions to NLEEs whose balance number is two. Because, if the balance number is one, usually the MSE method can be easily provided exact solitary wave solutions, but if the balance number is greater than one, in general there arise complications in solving the NLEEs via the MSE method. One cannot use the MSE method in straight away, i.e. the method has some shortcomings. If the solution of $\psi(\xi)$ consists of polynomial of the wave variable ξ , it will not be the solitary wave solution, since it does not meet the condition $|u| \rightarrow 0$ as $\xi \rightarrow \pm\infty$ for solitary wave solution. In this case, we have set each coefficient of the polynomial must be zero. This constraint limits is crucial to solve NLEEs for the balance number more than one. By using this achieved process in this dissertation, we have implemented the MSE method to obtain soliton solutions to the KdV equation, the Boussinesq equation, the fifth-order KdV equation, the modified Schamel equation for acoustic waves in plasma physics, the modified KP equation for acoustic waves in plasma physics and the strain wave equation in microstructured solids for both non-dissipative and dissipative cases. In fact, we have derived general solitary wave solutions to these equation associated with arbitrary constants, and for particular values of these constants solitons are originated from the general solitary wave solutions, shown in Chapter 4. We have illustrated the solitary wave properties of the solutions for various values of the free parameters by means of the graphs, displayed in Chapter 5. This shows that the solitary wave solutions to the NLEEs

studied in this thesis are soliton, bell shape soliton, singular bell shape soliton, anti-bell shape soliton, singular anti-bell shape soliton, periodic solution, singular periodic solution, kink, singular kink etc. Using this method, we have found some fresh and more general solutions other than the existing methods, such as, the basic (G'/G) -expansion method. For balance number two, we have emphasized the implementation of the MSE method, how to solve NLEEs and also the comparison between the MSE method and the well-known existing (G'/G) -expansion method are presented in Chapter 6.

Therefore, this dissertation shows that the MSE method is very effective, useful, competent, more powerful and can be used for solving many others NLEEs in mathematical physics, applied mathematics, plasma physics and engineering.

Since the MSE method is very efficient and powerful mathematical tool, we have found some significant solutions to NLEEs. Some researchers previously established the MSE method for balance number one and in this dissertation, we have developed a process to use the MSE method and employed it to investigate solutions to NLEEs for balance number two. Therefore, future researchers might get a gorgeous way in looking for close-form solitary wave solutions to other NLEEs by this method, when the balance number is two. The next research may be: whether our developed process is sufficient in solving NLEEs for balance number greater than two, or it needs to develop further technique.

References

- Abazari, R. The (G'/G) -expansion method for Tziteica type nonlinear evolution equations, *Math. Comput. Modelling*, 52 (2010) 1834-1845.
- Abdou, M.A. The extended tanh method and its applications for solving nonlinear physical models, *Appl. Math. Comput.*, 190(1) (2007) 988-996.
- Ablowitz, M.J. and Clarkson, P.A. *Soliton, nonlinear evolution equations and inverse scattering*, Cambridge University Press, New York, 1991.
- Akbar, M.A. Hj, N.Ali, N.H.M. and Zayed, E.M.E. Abundant exact traveling wave solutions of the generalized Bretherton equation via (G'/G) -expansion method, *Commun. Theor. Phys.*, 57 (2012a) 173-178.
- Akbar, M.A. Ali, N.H.M. and Zayed, E.M.E. A generalized and improved (G'/G) -expansion method for nonlinear evolution equations, *Math. Prob. Eng.*, 2012 (2012b), 22 pages. DOI: 10.1155/2012/459879.
- Akbar, M.A. and Ali, N.H.M. New Solitary and Periodic Solutions of Nonlinear Evolution Equation by Exp-function Method, *World Appl. Sci. J.*, 17(12) (2012) 1603-1610.
- Akbar, M.A. Ali, N.H.M. and Mohyud-Din, S.T. Further exact traveling wave solutions to the (2+1)-dimensional Boussinesq and Kadomtsev-Petviashvili equation, *J. Comput. Analysis Appl.*, 15(3) (2013) 557-571.
- Alam, M.N. Akbar, M.A. and Khan, K. Some new exact traveling wave solutions to the (2+1)-dimensional breaking soliton equation, *World App. Sci. J.*, 25(3) (2013a) 500-523.

- Alam, M.N. Akbar, M.A. and Roshid, H.O. Study of nonlinear evolution equations to construct traveling wave solutions via the new approach of the generalized (G'/G) -expansion method, *Math. Stat.*, 1(3) (2013b) 102-112.
- Alam, M.N. Akbar, M.A. and Hoque, M.F. Exact traveling wave solutions of the (3+1)-dimensional mKdV-ZK equation and the (1+1)-dimensional compound KdVB equation using new approach of the generalized (G'/G) -expansion method, *Pramana-J. Phys.*, 83(3) (2014a) 317-329.
- Alam, M.N. Akbar, M.A. and Mohyud-Din, S.T. General traveling wave solutions of the strain wave equation in microstructured solids via the new approach of generalized (G'/G) -expansion method, *Alexandria Eng. J.*, 53 (2014b) 233-241.
- Alam, M.N. Akbar, M.A. and Roshid, H.O. Traveling wave solutions of the Boussinesq equation via the new approach of generalized (G'/G) -expansion method, *SpringerPlus* 3:43 (2014c). DOI:10.1186/2193-1801-3-43.
- Alam, M.N. Akbar, M.A. and Mohyud-Din, S.T. A novel (G'/G) -expansion method and its application to the Boussinesq equation, *Chin. Phys. B*, 23(2) (2014d) 020203.
- Alam, M.N. Akbar, M.A. Ullah, M.S. Islam, R. and Roshid, H.O. A note on novel (G'/G) -expansion method in nonlinear physics, *Sop Transactions on theoretical physics*, 1(2) (2014e) 82-100.
- Alam, M.N. and Akbar, M.A. Exact traveling wave solutions of the KP-BBM equation by using the new approach of generalized (G'/G) -expansion method, *SpringerPlus*, 2 (2013a) 617, DOI: 10.1186/2193-1801-2-617.

- Alam, M.N. and Akbar, M.A. Some new exact traveling wave solutions to the simplified MCH equation and the (1+1)-dimensional combined KdV-mKdV equations, J. Asso. Arab Uni. Basic Appl. Sci., (2013b). DOI: 10.1016/j.jaubas.2013.12.001.
- Alam, M.N. and Akbar, M.A. Traveling wave solutions of nonlinear evolution equations via the new generalized (G'/G) -expansion method, Uni. J. Comput. Math., 1(4) (2013c) 129-136.
- Alam, M.N. and Akbar, M.A. Application of the the new approach of generalized (G'/G) -expansion method to find exact solutions of nonlinear PDEs in mathematical physics, BIBECHANA, 10 (2014a) 58-70.
- Alam, M.N. and Akbar, M.A. The new approach of the generalized (G'/G) -expansion method for nonlinear evolution equations, Ain Shams Eng. J., 5(2) (2014b) 595-603.
- Alam, M.N. and Akbar, M.A. Traveling wave solutions for the mKdV equation and the Gardner equation by new approach of the generalized (G'/G) -expansion method, J. Egyptian Math. Society, 22 (2014c) 402-406.
- Alam, M.N. and Akbar, M.A. A new (G'/G) -expansion method and its application to the Burgers equation, Walailak J. Sci. Tech., 11(8) (2014d) 643-658.
- Alam, M.N. and Akbar, M.A. Traveling wave solutions of the nonlinear (1+1)-dimensional modified Benjamin-Bona-Mahony equation by using novel (G'/G) -expansion method, Phys. Review Res. Int., 4(1) (2014e) 147-165.
- Alam, M.N. Novel (G'/G) -expansion method and its application for solving nonlinear evolution equations in mathematical physics, M.Phil. thesis, 2014, Pabna University of Science & Technology, Pabna-6600, Bangladesh.

- Baldock, R.A. Robson, B.A. and Barrett, R.F. Application of an inverse scattering method to determine the effective interaction between composite particles, Nuclear Phys. A, 366(2) (1981) 270-280.
- Bekir, A. and Cevikel, A.C. The tanh-coth method combined with the Riccati equation for solving nonlinear coupled equation in mathematical physics, J. King Saud Uni.-Sci., 23 (2011) 127-132.
- Bekir, A. Application of the (G'/G) -expansion method for nonlinear evolution equations, Phys. Lett. A, 372 (2008) 3400-3406.
- Belgacem, F.B.M. Karaballi, A.A. and Kalla, S.L. Analytical investigations of the Sumudu transform and applications to integral production equations, Math. Prob. Engr., 2003 (2003) 103-118.
- Belgacem, F.B.M. and Karaballi, A.A. Sumudu transform Fundamental Properties investigations and applications, J. Appl. Mathe. Stochastic Analysis, 2006 (2006) Article ID 91083 1-23.
- Belgacem, F.B.M. Introducing and Analyzing Deeper Sumudu Properties, Nonlinear Studies J., 13(1) (2006) 23-41.
- Belgacem, F.B.M. Applications of the Sumudu Transform to Indefinite Periodic Parabolic Problems, Proceedings of the 6th International Conference on Mathematical Problems & Aerospace Sciences, (ICNPAA 06), Cambridge Scientific Publishers, Cambridge, UK, Chap., 6 (2007) 51-60.
- Belgacem, F.B.M. Sumudu Applications to Maxwell's Equations, PIERS Online, 5 (2009) 1-6.
- Belgacem, F.B.M. Sumudu Transform Applications to Bessel Functions and Equations, Appl. Math. Sci., 4(74) (2010) 3665 - 3686.

- Bluman, G.W. and Kumei, S. Symmetries and differential equations, Springer-Verlag, New York, 1989.
- Bock, T.L. and Kruskal, M.D. A two-parameter Miura transformation of the Benjamin-One equation, *Phys. Lett. A*, 74 (1979) 173-176.
- Chaurasia, V.B.L. Dubey, R.S. and Belgacem, F.B.M. Fractional radial diffusion equation analytical solution via Hankel and Sumudu transforms, *Math. Eng. Sci. Aerospace*, 3(2) (2012) 179-188.
- Chen, Y. and Wang, Q. Extended Jacobi elliptic function rational expansion method and abundant families of Jacobi elliptic functions solutions to (1+1)-dimensional dispersive long wave equation, *Chaos, solitons Fract.*, 24 (2005) 745-757.
- Domairry, G. Mohsenzadeh, A. and Famouri, M. The application of homotopy analysis method to solve nonlinear differential equation governing Jeffery-Hamel flow, *Commun. Nonlinear Sci. Numer. Simulat.*, 14(1) (2009) 85-95.
- El-Kalaawy, O. H. Exact solitary solution of Schamel equation in plasmas with negative ions, *Phy. of Plasmas*, 18, 112302 (2011); Doi: 10.1063/1.3657422.
- El-Wakil, S.A. and Abdou, M.A. New exact travelling wave solutions using modified extended tanh-function method, *Chaos, Solitons Fract.*, 31(4) (2007) 840-852.
- Feng, J. Li, W. and Wan, Q. Using (G'/G) -expansion method to seek the traveling wave solution of Kolmogorov-Petrovskii-Piskunov equation, *Appl. Math. Comput.*, 217 (2011) 5860-5865.
- Fan, E.G. Extended tanh-function method and its applications to nonlinear equations, *Phys. Lett. A*, 277 (2000) 212-218.

- Fan, E.G. Multiple traveling wave solutions of nonlinear evolution equations using a unified algebraic method, *J. Phys. A Math. Gen.*, 35 (2002) 6853-6872.
- Ganji, D.D. Afrouzi, G.A. and Talarposhti, R.A. Application of variational iteration method and homotopy perturbation method for nonlinear heat diffusion and heat transfer equations, *Phys. Lett. A*, 368 (2007) 450-457.
- Ganji, D.D. and Rafei, M. Solitary wave solutions for a generalized Hirota-Satsuma coupled KdV equation by homotopy perturbation method, *Phys. Lett. A*, 356 (2006) 131-137.
- Ganji, D.D. The application of He's homotopy perturbation method to nonlinear equations arising in heat transfer, *Phys. Lett. A*, 355 (2006) 137-141.
- Ghosh, S. and Nandy, S. Inverse scattering method and vector higher order nonlinear Schrodinger equation, *Nuclear Phys. B*, 561(3) (1999) 451-466.
- Gomez, C.A. and Salas, A.H. The generalized tanh-coth method to special types of the fifth-order KdV equation, *Appl. Math. Comput.*, 203(2) (2008) 873-880.
- Guo, A.L. and Lin, J. Exact solutions of (2+1)-dimensional HNLS equation, *Commun. Theor. Phys.*, 54 (2010) 401-406.
- Guo, S. and Zhou, Y. The extended (G'/G) -expansion method and its applications to the Whitham-Broer-Like equations and coupled Hirota-Satsuma KdV equations, *Appl. Math. Comput.*, 215(9) (2010) 3214-3221.
- Guo, S. Mei, L. Zhou, V. and Li, C. The extended Riccati equation mapping method for variable-coefficient diffusion-reaction and mKdV equations, *Appl. Math. Comput.*, 217(13) (2011) 6264-6272.

- Hafez, M.G. Alam, M.N. and Akbar, M.A. Exact traveling wave solutions to the Klein-Gordon equation using the novel (G'/G) -expansion method, *Results Phys.*, 4 (2014) 177-184.
- Hafez, M.G. Alam, M.N. and Akbar, M.A. Traveling wave solutions for some important coupled nonlinear physical models via the coupled Higgs equation and the Maccari system, *J. King Saud Univ.-Sci.*, 27 (2015) 105-112.
- Hasan, S.M.S. Alam, M.N. Uddin, M.S. Hasan, M.S. and Akbar, M.A. Exact traveling wave solutions of the fifth-order KdV equation via the new approach of generalized (G'/G) -expansion method, *Int. J. Math. Comput Res.*, 1(11) (2013) 283-302.
- He, J.H. and Shou, D.H. Application of parameter-expanding method to strongly nonlinear oscillators, *Int. J. Nonlinear Sci. Numer. Simulat.*, 8 (2007) 121-124.
- He, J.H. and Wu, X.H. Exp-function method for nonlinear wave equations, *Chaos, Solitons Fract.*, 30 (2006) 700-708.
- He, Y. Li, S. and Long, Y. Exact solutions of the Klein-Gordon equation by modified exp-function method, *Int. Math. Forum.*, 7(4) (2012) 175-182.
- Helal, M.A. and Mehana, M.S. A comparison between two different methods for solving KdV-Burgers equation, *Chaos, Solitons Fract.*, 28 (2006) 320-326.
- Hirota, R. and Satsuma, J. Soliton solutions of a coupled KdV equation, *Phys. Lett. A*, 85 (1981) 404-408.
- Hirota, R. Exact envelope soliton solutions of a nonlinear wave equation, *J. Math. Phys.*, 14 (1973) 805-810.

- Hirota, R. The direct method in soliton theory, Cambridge University Press, Cambridge, 2004.
- Hu, J.L. and Zhang, H. A new method for finding exact traveling wave solutions to nonlinear partial differential equations, *Phys. Lett. A*, 286 (2001) 175-179.
- Hu, J.L. Explicit solutions to three nonlinear physical models, *Phys. Lett. A*, 287 (2001) 81-89.
- Inc, M. and Evans, D.J. On traveling wave solutions of some nonlinear evolution equations, *Int. J. Comput. Math.*, 8 (2004) 191-202.
- Jawad, A.J.M. Petkovic, M.D. and Biswas, A. Modified simple equation method for nonlinear evolution equations, *Appl. Math. Comput.*, 217 (2010) 869-877.
- Jawad, A.J.M. New exact solutions of nonlinear partial differential equations using Tan-Cot function method, *Studies in Math. Sci.*, 5(2) (2012) 13-25.
- Jianming, L. Jie, D. and Wenjun, Y. Backlund transformation and new exact solutions of the Sharma-Tasso-Olver equation, *Abstract and Appl. Analysis*, 2011 (2011) Article ID 935710, 8 pages.
- Joneidi, A.A. Domairry, G. and Babaelahi, M. Three analytical methods applied to Jeffery-Hamel flow, *Communi. Non. Sci. Numer. Simulat.*, 15(11) (2010) 3423-3434.
- Kaya, D. An explicit solution of coupled viscous burgers equation by the decomposition method, *Int. J. Math. Sci.*, 27 (2001) 675-680.
- Kaya, D. An application for the decomposition method for the KdVB equation, *Appl. Math. Comput.*, 152 (2004) 279-288.

- Khan, K. Akbar, M.A. and Alam, M.N. Traveling wave solutions of the nonlinear Drinfel'd-Sokolov-Wilson equation and modified Benjamin-Bona-Mahony equations, J. Egyptian Math. Soc., 21 (2013) 233-240.
- Khan, K. and Akbar, M. A. Application of $Exp(-\varphi(\xi))$ -expansion method to find the exact solutions of modified Benjamin-Bona-Mahony equation, World Appl. Sci. J., 24(10), (2013a), 1373-1377.
- Khan, K. and Akbar, M.A. Traveling wave solutions of some coupled nonlinear evolution equations, ISRN Math. Phys., 2013 (2013b) Art. ID 685736, 8 pages.
- Khan, K. and Akbar, M. A. Exact and solitary wave solutions for Tzitzeica-Dodd-Bullough and the modified KdV-Zakharov-Kuznetsov equations using the modified simple equation method, Ain Shams Eng. J. 4 (2013c) 903-909.
- Khan, K. and Akbar, M. A. Traveling wave solutions of the (2 + 1)-dimensional Zoomeron equation and the Burgers equations via the MSE method and the Exp-function method, Ain Shams Eng. J. 5 (2014), 247–256.
- Khan, K. Study of analytical methods to find exact solutions of nonlinear evolution equations in mathematical physics, M.Phil. thesis, 2014, Pabna University of Science & Technology, Pabna-6600, Bangladesh.
- Khan, M.A. and Akbar, M.A. Exact and solitary wave solutions to the generalized fifth-order KdV equation by using the modified simple equation method, Appl. Comput. Math., 4(3) (2015a) 122-129.
- Khan, M.A. and Akbar, M.A. Solitary wave solutions to the strain wave equation in microstructured solids through the modified simple equation method, Phy. Sci. Int. J., (2015b) (accepted for publication).

- Khan, M.A. and Akbar, M.A. Solitary wave solutions to the strain wave equation in microstructured solids and fifth-order KdV equation through the (G'/G) -expansion method, *Appl. Comput. Math.*, (submitted, 2015c).
- Kheiri, H. Moghaddam, M. R. and Vafaei, V. Application of the (G'/G) -expansion method for the Burgers, Burgers-Huxley and modified Burgers-KdV equations, *Pramana-J. Phys.*, 76(6) (2011) 831-842.
- Kichenassamy, S. and Olver, P. J. Existence and Nonexistence of Solitary Wave Solutions to Higher-Order Model Evolution Equations, *Siam J. Math. Anal.*, 23(5) (1992) 1141-1166.
- Leble, S.B. and Ustinov, N.V. Darboux transformations, deep reductions and solitons, *J. Phys. A: Math. Gen.*, 26 (1993) 5007-5016.
- Li, B. Chen, Y. Xuan, H. and Zhang, H. Generalized Riccati equation expansion method and its application to the (3+1)-dimensional Jumbo-Miwa equation, *Appl. Math. Comput.*, 152(2) (2004) 581-595.
- Ma, W.X. and Zhu, Z. Solving the (3+1)-dimensional generalized KP and BKP equations by the multiple exp-function algorithms, *Appl. Math. Comput.*, 218 (2012) 11871–11879.
- Makukula, Z.G. Sibanda, P. and Motsa, S.S. A note on the solution of the von Kármán equations using series and Chebyshev spectral methods, *Boundary Value Prob.*, 2010 (2010) Article ID 471793, 17 pages.
- Malfliet, W. and Hereman, W. The tanh method: II. Perturbation technique for conservative systems, *Phys. Scr.*, 54 (1996) 563-569.

- Manafian, J. and Zamanpour, I. Analytical treatment of the coupled Higgs equation and Maccari system via Exp-Function Method, *Acta Universitatis Apulensis*, 33 (2013) 203- 216.
- Matveev, V.B. and Salle, M.A. Darboux transformation and solitons, Springer, Berlin, 1991.
- McOwen, R.C. Partial Differential equations: Method and Applications, Tsinghua University press, Hong Kong, 2004.
- Misirli, E. and Gurefe, Y. Exp-function method for solving nonlinear evolution equations, *Math. Comput. Appl.*, 16 (2011) 258-266.
- Miura, M.R. Backlund transformation, Springer, Berlin, 1978.
- Mohyud-Din, S.T. Noor, M.A. and Noor, K.I. Exp-function method for solving higher-order boundary value problems, *Bull. Inst. Math.*, 4 (2009a) 219-234.
- Mohyud-Din, S.T. Noor, M.A. and Noor, K.I. Modified Variational Iteration Method for Solving Sine-Gordon Equations, *World Appl. Sci. J.*, 6(7) (2009b) 999-1004.
- Mohyud-Din, S.T. Noor, M.A. and Noor, K.I. Variational Iteration Method for Solving Flierl-petviashvili Equation Using He's Polynomials and Pade' Approximants, *World Appl. Sci. J.*, 6(9) (2009c) 1298-1303.
- Mohyud-Din, S.T. Variational iteration method for solving fifth-order boundary value problems using He's polynomials, *Math. Prob. Eng.*, 2008 (2008) Article ID 954794.

- Motsa, S.S. Sibanda, P. and Shateyi, S. A new spectral-homotopy analysis method for solving a nonlinear second order BVP, *Communi. Nonlinear Sci. Numer. Simulat.*, 15(9) (2010a) 2293-2302.
- Motsa, S.S. Sibanda, P. Awad, F.G. and Shateyi, S. A new spectral-homotopy analysis method for the MHD Jeffery-Hamel problem, *Comput. Fluids*, 39(7) (2010b) 1219–1225.
- Naher, H. Abdullah, A.F. and Akbar, M.A. The Exp-function method for new exact solutions of the nonlinear partial differential equations, *Int. J. Phy. Sci.*, 6(29) (2011a) 6706-6716.
- Naher, H. Abdullah, F.A. and Akbar, M.A. The (G'/G) -expansion method for abundant traveling wave solutions of Caudrey-Dodd-Gibbon equation, *Math. Prob. Eng.*, 2011 (2011b) Article ID 218216, 11 pages.
- Naher, H. Abdullah, A.F. and Akbar, M.A. New traveling wave solutions of the higher dimensional nonlinear partial differential equation by the Exp-function method, *J. Appl. Math.*, 2012 (2012) Article ID 575387, 14 pages.
- Naher, H. Abdullah, F.A. and Akbar, M.A. Generalized and improved (G'/G) -expansion method for (3+1)-dimensional modified KdV-Zakharov-Kuznetsev equation, *PLoS ONE* 8(5) (2013): e64618, DOI:10.1371/journal.pone.0064618
- Naher, H. and Abdullah, F.A. Some new solutions of the combined KdV-MKdV equation by using the improved (G'/G) -expansion method, *World Appl. Sci. J.*, 16(11) (2012a) 1559-1570.

- Naher, H. and Abdullah, F.A. The improved (G'/G) -expansion method for the (2+1)-dimensional modified Zakharov-Kuznetsov equation, *J. Appl. Math.*, 2012 (2012b) Article ID 438928, 20 pages.
- Naher, H. and Abdullah, F.A. New approach of (G'/G) -expansion method and new approach of generalized (G'/G) -expansion method for nonlinear evolution equation, *AIP Advances*, 3 (2013) 032116.
- Naher, H. and Abdullah, F.A. Further extension of the generalized and improved (G'/G) -expansion method for nonlinear evolution equation, (2014) DOI: 10.1016/j.jaubas.2014.05.005.
- Nassar, H.A. Abdel-Razek, M.A. and Seddeek, A.K. Expanding the tanh-function method for solving nonlinear equations, *Appl. Math.*, 2 (2011) 1096–1104.
- Noor, M.A. Mohyud-Din, S.T. and Tahir, M. Modified variational iteration methods for Thomas-Fermi equation, *World Appl. Sci. J.*, 4(4) (2008) 479-486.
- Noor, M.A. and Mohyud-Din, S.T. Modified variational iteration method for Goursat and Laplace Problems, *World Appl. Sci. J.*, 4(4) (2008) 487-498.
- Olver, P.J. Applications of Lie groups to differential equations, Springer-Verlag, New York, 1986.
- Pastrone, F. Cermelli, P. and Porubov, A. Nonlinear waves in 1-D solids with microstructure, *Mater. Phys. Mech.*, 7 (2004) 9-16.
- Pastrone, F. Hierarchy of Nonlinear waves in complex microstructured solids, *Int. con. commun. nonlinear waves*, (2009) 5-7.
- Porubov, A.V. and Pastrone, F. Non-linear bell-shaped and kink-shaped strain waves in microstructured solids, *Int. J. Nonlinear Mech.*, 39(8) (2004) 1289-1299.

- Porubov, A.V. Periodical solution to the nonlinear dissipative equation for surface waves in a convecting liquid layer, *Phys. Lett. A*, 221 (1996) 391-394.
- Rahman, N. Alam, M.N. Roshid, H.O. Akter, S. and Akbar, M.A. Application of $\exp(-\Phi(\eta))$ -expansion method to find the exact solutions of Shorma-Tasso-Olver equation, *African J. Math. Comput. Sci. Resear.*, 7(1) (2014a) 1-6.
- Rahman, N. Roshid, H.O. Alam, M.N. and Zafor, S. Exact traveling Wave Solutions of the nonlinear (2+1)-dimensional typical breaking soliton equation via $\text{Exp}(-\Phi(\xi))$ -expansion method, *Inter. J. Sci. Eng. Tech.*, 3(2) (2014b) 93-97.
- Rogers, C. and Schief, W.K. Backlund transformations and their applications, Cambridge University Press, New York, USA, 2002.
- Rogers, C. and Shadwick, W.F. Backlund transformations and their applications, Vol. 161 of *Mathematics in Science and Engineering*, Academic Press, New York, USA, 1982.
- Roozi, A. and Mahmeiani, A.G. The (G'/G) -expansion method for (2+1)-dimensional Kadomtsev-Petviashvili equation, *World Appl. Sci. J.*, 13(10) (2011) 2231-2234.
- Roshid, H.O. Alam, M.N. Hossain, M.M. Ullah, M.S. Islam, R. and Akbar, M.A. Exact traveling wave solutions for the (2+1)-dimensional ZK-BBM equation by $\exp(-\Phi(\eta))$ -expansion method, *Global J. Sci. Fronti. Resear.*, 14(2) (2014) 1-5.

- Salam, M.A. Traveling wave solution of modified Liouville equation by means of modified simple equation method, *ISRN Appl. Math.*, 2012 (2012), Article ID 565247, 4 pages.
- Salas, A.H. and Gomez, C.A. Application of the Cole-Hopf transformation for finding exact solutions to several forms of the seventh-order KdV equation, *Math. Prob. Eng.*, 2010 (2010) Art. ID 194329 14 pages.
- Salas, A.H. and Gomez, C.A. Computing exact solutions for some fifth KdV equations with forcing term, *Appl. Math. Comput.*, 204(1) (2008) 257-260.
- Salas, A. Some exact solutions for the Caudrey-Dodd-Gibbon equation, *Math. Phys.*, arXiv: 0805.2969v2 [math-ph] 21 may 2008.
- Samsonov, A.M. *Strain Solitons and How to Construct Them*, Chapman and Hall/CRC, Boca Raton, Fla, USA, 2001.
- Sekulic, D. L. Sataric, M. V. and Zivanov, M. B. Symbolic computation of some new nonlinear partial differential equations of nanobiosciences using Modified extended tanh-function method, *Appl. Math. Comput.* 218 (2011) 3499-3506.
- Shakeel, M. and Mohyud-Din, S.T. New (G'/G) -expansion method and its application to the ZK-BBM equation, (2014). DOI: 10.1016/j.jaubas.2014.02.007.
- Shakeel, M. Hassan, Q.M. and Ahmad, J. Applications of the novel (G'/G) -expansion method for a time fractional simplified modified MCH equation, *Abstract Appl. Analysis*, 2014 (2014) Article ID 601961 16 pages.
- Sibanda, P. Makukula, Z.G. and Motsa, S.S. A novel numerical technique for two-dimensional laminar flow between two moving porous walls, *Math. Prob. Eng.*, 2010 (2010) Article ID 528956, 15 pages.

- Sirendaoreji, Auxiliary equation method and new solutions of Klein-Gordon equations, *Chaos, Solitons Fract.*, 31 (2007) 943-950.
- Soliman, A.A. and Abdo, H.A. New exact solutions of nonlinear variants of the RLW and PHI-four and Boussinesq equations based on modified extended direct algebraic method, *Int. J. Nonlinear Sci.*, 7(3) (2009) 274-282.
- Taghizade, N. and Neirameh, A. The solutions of TRLW and Gardner equations by (G'/G) -expansion method, *Int. J. Nonlinear Sci.*, 9(3) (2010) 305-310.
- Taghizadeh, N. and Mirzazadeh, M. The first integral method to some complex nonlinear partial differential equations, *J. Comput. Appl. Math.*, 235 (2011) 4871-4877.
- Taha, W. M. Noorani, M. S. M. and Hashim, I. New exact solutions of ion-acoustic wave equations by (G'/G) -expansion method, *J. App. Mathematics*, 2013 (2013), Article id: 810729, 11 pages.
- Uddin, M.S. Alam, M.N. Hossain, S.M.S. Hasan, M.S. and Akbar, M.A. Some new exact traveling wave solutions to the (3+1)-dimensional Zakharov-Kuznetsov equation and the Burgers equations via $Exp(-\Phi(\eta))$ -expansion method, *Front. Math. Its Appl.*, 1(1) (2014) 1-8. DOI: 10.12966/fmia.03.01.2014.
- Wang, M. Li, X. and Zhang, J.L The (G'/G) -expansion method and traveling wave solutions of nonlinear evolution equations in mathematical physics, *Phys. Lett. A*, 372 (2008a) 417-423.
- Wang, M.L. Zhang, J.L. and Li, X.Z. Application of the (G'/G) -expansion method to traveling wave solutions of the Broer-Kaup and the approximate long water wave equations, *Appl. Math. Comput.*, 206 (2008b) 321-326.

- Wang, M.L. and Li, X.Z. Extended F-expansion method and periodic wave solutions for the generalized Zakharov equations, *Phys. Lett. A*, 343 (2005) 48-54.
- Wang, M.L. and Zhou, Y.B. The periodic wave solutions for the Klein-Gordon-Schrodinger equations, *Phys. Lett. A*, 318 (2003) 84-92.
- Wang, M. Solitary wave solutions for variant Boussinesq equations, *Phy. Lett. A*, 199 (1995) 169-172.
- Watugala, G.K. Sumudu transform: a new integral transform to solve differential equations and control engineering problems, *Inter. J. Math. Educat. Sci. Tech.*, 24(1) (1993) 35-43.
- Wazwaz, A.M. A sine-cosine method for handle nonlinear wave equations, *Appl. Math. Comput. Modeling*, 40 (2004) 499-508.
- Wazwaz, A.M. *Partial Differential Equations and Solitary Waves Theory*, Higher Education Press, Beijing and Springer-Verlag Berlin Heidelberg, 2009.
- Weiss, J. Tabor, M. and Carnevale, G. The Painlevé property for partial differential equations, *J. Math. Phys.*, 24 (1982) 522-526.
- Xiao, L. Er-Qiang, L. and Wang, M.L. The $(G'/G, 1/G)$ -expansion method and its application to traveling wave solutions of the Zakharov equations, *Appl. Math. J. Chin. Univ.*, 25(4) (2010) 454-462.
- Xu, G. An elliptic equation method and its applications in nonlinear evolution equations, *Chaos, Solitons Fract.*, 29 (2006) 942-947.
- Yan, Z.Y. and Zhang, H.Q. New explicit and exact traveling wave solutions for a system of variant Boussinesq equations in mathematical physics, *Phys. Lett. A*, 252 (1999) 291-296.

- Yan, Z. and Zhang, H. New explicit solitary wave solutions and periodic wave solutions for Whitham Broer-Kaup equation in shallow water, *Phys. Lett. A*, 285(5-6) (2001) 355-362.
- Yildirim, A. and Pinar, Z. Application of the exp-function method for solving nonlinear reaction diffusion equations arising in mathematical biology, *Comput. Math. Appl.*, 60 (2010) 1873-1880.
- Yusufoglu, E. and Bekir, A. Solitons and periodic solutions of coupled nonlinear evolution equations by using Sine-Cosine method, *Int. J. Comput. Math.*, 83(12) (2006) 915-924.
- Yusufoglu, E. and Bekir, A. Exact solution of coupled nonlinear evolution equations, *Chaos, solitons Fract.*, 37 (2008) 842-848.
- Zabusky, N.J. and Kruskal, M.D. Interaction of solitons in collisionless plasma and the recurrence of initial states, *Phys. Rev. Lett.*, 15, 240–243, (1965).
- Zayed, E. M. E. Amer, Y. A. and Shohib, R. M. A. The improved generalized Riccati equation mapping method and its application for solving a nonlinear partial differential equation (PDE) describing the dynamics of ionic currents along microtubules, *Academic J.*, 9(8) (2014) 238-248.
- Zayed, E.M.E. Hoda, S.A.I. and Abdelaziz, M.A.M. Traveling wave solutions of the nonlinear (3+1)-dimensional Kadomtsev-Petviashvili equation using the two variables $(G'/G, 1/G)$ -expansion method, *J. Appl. Math.*, 2012 (2012) Article ID 560531; 2012. 8 pages.
- Zayed, E.M.E. Zedan, H.A. and Gepreel, K.A. On the solitary wave solutions for nonlinear Hirota-Sasuma coupled KDV equations, *Chaos, Solitons Fract.*, 22 (2004a) 285-303.

- Zayed, E.M.E. Zedan, H.A. and Gepreel, K.A. On the solitary wave solutions for nonlinear Euler equations, *Appl. Anal.*, 83 (2004b) 1101-1132.
- Zayed, E.M.E. and Abdelaziz, M.A.M. The Two variable $(G'/G, 1/G)$ -expansion method for solving the nonlinear KdV-m KdV equation, *Math. Prob. Eng.*, 2012 (2012) Article ID 725061; 2012. 14 pages.
- Zayed, E.M.E. and Al-Joudi, S. Applications of an extended (G'/G) -expansion method to find exact solutions of nonlinear PDEs in mathematical physics, *Math. Prob. Eng.*, 2010 (2010) Article ID 768573, 19 pages.
- Zayed, E.M.E. and Arnous, The modified simple equation method with applications to (2+1)-dimensional systems of nonlinear evolution equations in mathematical physics, *Sci. Res. and Essays, USA, Aca. J.*, 8(40) (2013a) 1973-1982.
- Zayed, E.M.E. and Arnous, A.H. Exact traveling wave solutions of nonlinear PDEs in mathematical physics using the modified simple equation method, *Appl. Math.: An Int. J.*, 8(2) (2013b) 553-572.
- Zayed, E.M.E. and El-Malky, M.A.S. The extended (G'/G) -expansion method and its applications for solving the (3+1)-dimensional nonlinear evolution equations in mathematical physics, *Global J. Sci. Front. Resear.*, 11(1) (2011) 68-80.
- Zayed, E.M.E. and Gepreel, K.A. New applications of an improved (G'/G) -expansion method to construct the exact solutions of nonlinear PDEs, *Inter. J. Non. Sci. Numeri. Simul.*, 11(4) (2010) 273-283.

- Zayed, E.M.E. and Gepreel, K.A. The (G'/G) -expansion method for finding traveling wave solutions of nonlinear partial differential equations in mathematical physics, *J. Math. Phys.*, 50(1) (2009) Article ID 013502, 12 pages.
- Zayed, E.M.E. and Ibrahim, S.A.H. Modified simple equation method and its applications for some nonlinear evolution equations in mathematical physics, *Int. J. Comput. Appl.*, 67(6) (2013) 39-44.
- Zayed, E.M.E. and Ibrahim, S.A.H. Exact solutions of nonlinear evolution equations in mathematical physics using the modified simple equation method, *Chin. Phys. Lett.*, 29(6) (2012) 060201.
- Zayed, E.M.E. The (G'/G) -expansion method and its applications to some nonlinear evolution equations in the mathematical physics, *J. Appl. Math. Comput.*, 30 (2009a) 89-103.
- Zayed, E.M.E. New traveling wave solutions for higher dimensional nonlinear evolution equations using a generalized (G'/G) -expansion method, *J. Phys. A: Math. Theor.*, 42(19) (2009b) Article ID 195202.
- Zayed, E.M.E. Traveling wave solutions for higher dimensional nonlinear evolution equations using the (G'/G) -expansion method, *J. Appl. Math. Inform.*, 28 (2010) 383-395.
- Zayed, E.M.E. The (G'/G) -expansion method combined with the Riccati equation for finding exact solutions of nonlinear PDEs, *J. Appl. Math. Inform.*, 299(1-2) (2011a) 351-367.
- Zayed, E.M.E. A note on the modified simple equation method applied to Sharma-Tasso-Olver equation, *Appl. Math. Comput.*, 218 (2011b) 3962-3964.

- Zayed, E.M.E. The modified simple equation method and its applications for solving nonlinear evolution equations in mathematical physics, Commun. Appl. Nonlinear Analysis, 20(3) (2013) Pages 95-104.
- Zhang, H.Q. New application of the (G'/G) -expansion method, Commun. Nonlinear Sci. Numer. Simulat., 14 (2009) 3220-3225.
- Zhang, J. Jiang, F. and Zhao, X. An improved (G'/G) -expansion method for solving nonlinear evolution equations, Inter. J. Comput. Math., 87(8) (2010) 1716-1725.
- Zhang, W. The extended tanh method and the Exp-function method to solve a kind of nonlinear heat equation, Math. Prob. Eng., 2010 (2010) Article ID 935873, 12 pages.
- Zhu, S.D. The generalizing Riccati equation mapping method in nonlinear evolution equation: application to (2+1)-dimensional Boiti-Leon-Pempinelle equation, Chaos, Solitons Fract., 37(5) (2008) 1335-1342.